

MINI 
TECNO
small but strong

NDFT
ECFT

Motoriduttori CC pendolari
DC Helical parallel gearmotors

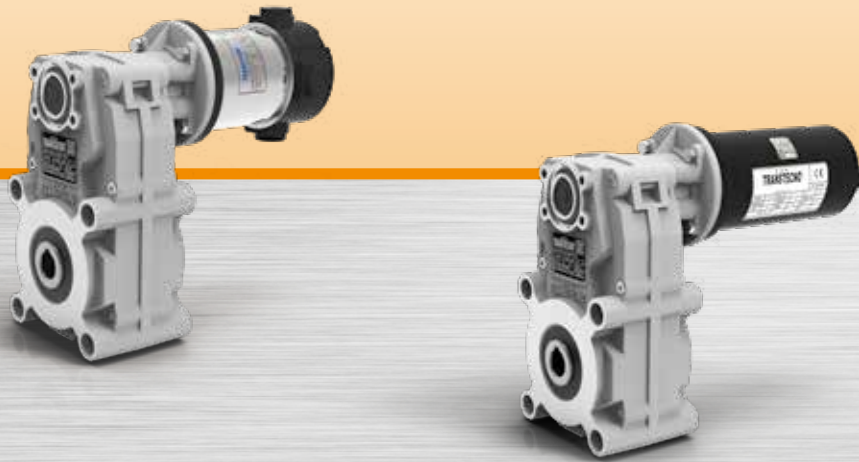

MINI 
TECNO brand of
TRANSTECNO



DC

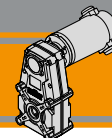

Indice	Index	Pag. Page
Caratteristiche tecniche	<i>Technical features</i>	BF2
Designazione	<i>Classification</i>	BF2
Sensi di rotazione	<i>Direction of rotation</i>	BF3
Simbologia	<i>Symbols</i>	BF3
Lubrificazione	<i>Lubrication</i>	BF3
Carichi radiali	<i>Radial loads</i>	BF4
Dati tecnici	<i>Technical data</i>	BF5
Motori applicabili	<i>Motor adapters</i>	BF6
Dimensioni	<i>Dimensions</i>	BF7

Questa sezione annulla e sostituisce ogni precedente edizione o revisione. Qualora questa sezione non Vi sia giunta in distribuzione controllata, l'aggiornamento dei dati ivi contenuto non è assicurato. **In tal caso la versione più aggiornata è disponibile sul nostro sito internet www.transtecno.com**

This section replaces any previous edition and revision. If you obtained this catalogue other than through controlled distribution channels, the most up to date content is not guaranteed. In this case the latest version is available on our web site www.transtecno.com

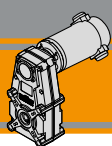

**NDFT
ECFT**

Motoriduttori CC pendolari DC Helical parallel gearmotors



Caratteristiche tecniche

Technical features

I motoriduttori CC pendolari a magneti permanenti in neodimio **NDFT** e in ferrite **ECFT** hanno le seguenti caratteristiche principali:

NDFT neodymium permanent magnets and **ECFT** ferrite permanent magnets DC helical parallel gearmotors range has the following main features:

- Alimentazione in bassa tensione 12/24 Vcc
- Possibilità di montaggio encoder e freno
- Potenze motore disponibili da 100 a 800W S2
- Carcasce dei riduttori in pressofusione di alluminio
- Lubrificazione permanente con olio sintetico
- Ingranaggi cilindrici a denti elicoidali.

- Low voltage power supply 12/24 Vdc
- Suitable for encoder and brake assembly
- Motor power ratings available from 160 to 250W S2
- Die-cast aluminum housing
- Permanent synthetic oil long-life lubrication
- helical gears.

NDFT 105/...

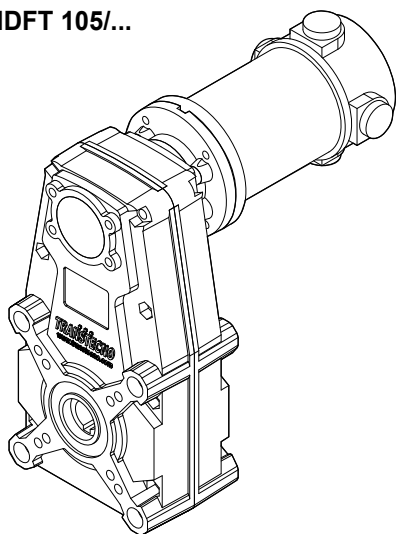

ECFT 105/...

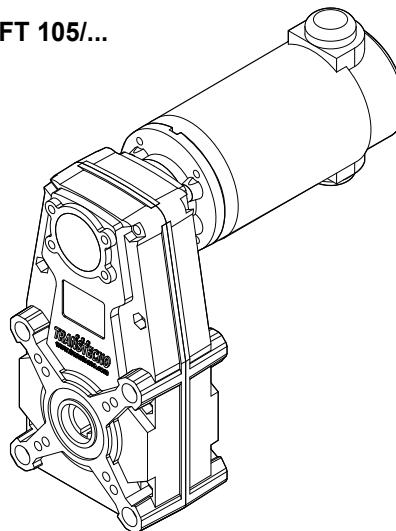

Designazione

Classification

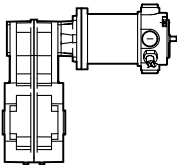
MOTORIDUTTORE / GEARMOTOR					
NDFT	120/146	U	60.63	O20	240
Tipo Type	Grandezza Size	Versione Riduttore Gearbox Version	Rapporto Ratio	Albero di uscita Output shaft	Versione Motore Motor Version
NDFT 	120/105/3 120/105/4 180/105/3	U...	Vedere tabella See tables	Vedere tabella See tables	120 240

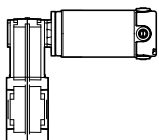
MOTORIDUTTORE / GEARMOTORS					
ECFT	180/146	U	60.63	O20	B5
Tipo Type	Grandezza Size	Versione Version	Rapporto Ratio	Albero cavo uscita Hollow output shaft	Versione motore Motor version
ECFT 	070/105/3 070/105/4 100/105/3 180/105/3	U...	vedi tabelle see tables	vedi tabelle see tables	120 240 12E 24E

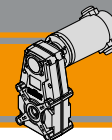

Sensi di rotazione

Direction of rotation

NDFT 105/3
ECFT 105/3

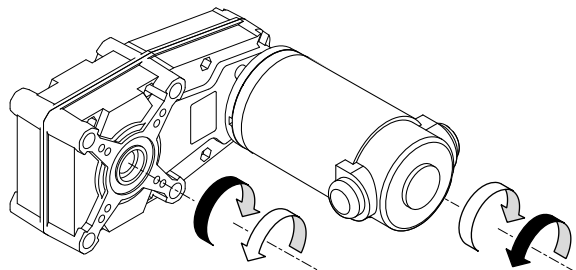
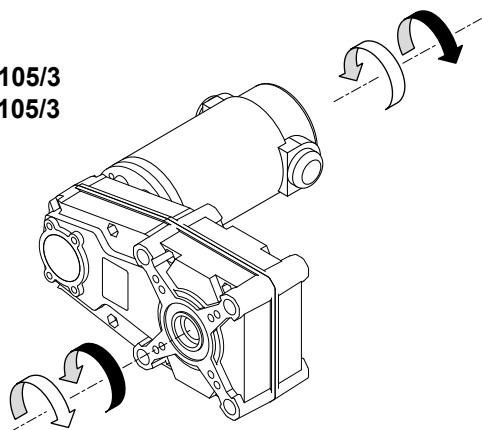

NDFT 105/4
ECFT 105/4

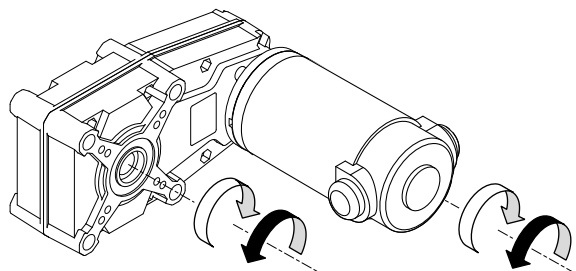
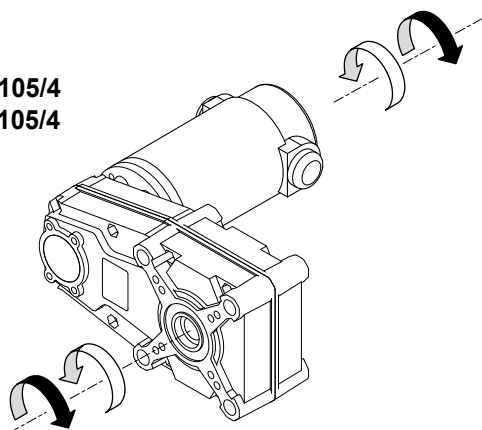

Simbologia

Symbols

n_1	[min^{-1}]	Velocità in ingresso / <i>Input speed</i>
n_2	[min^{-1}]	Velocità in uscita / <i>Output speed</i>
i		Rapporto di riduzione / <i>Ratio</i>
P_1	[kW]	Potenza in entrata / <i>Input power</i>
M_2	[Nm]	Coppia nominale in uscita in funzione di P_1 / <i>Output torque referred to P_1</i>
P_{n1}	[kW]	Potenza nominale in entrata / <i>Nominal input power</i>
M_{n2}	[Nm]	Coppia nominale in uscita in funzione di P_{n1} / <i>Nominal output torque referred to P_{n1}</i>
sf		Fattore di servizio / <i>Service factor</i>
R_2	[N]	Carico radiale ammissibile in uscita / <i>Permitted output radial load</i>
A_2	[N]	Carico assiale ammissibile in uscita / <i>Permitted output axial load</i>

Lubrificazione

Lubrication

Tutti i motoriduttori sono forniti completi di lubrificante sintetico viscosità 320, pertanto possono essere installati in qualunque posizione di montaggio e non necessitano di manutenzione.

Permanent synthetic oil long-life lubrication (viscosity grade 320) makes it possible to use the gearmotors in all mounting positions; for this reason they can be installed in any assembly position and do not require maintenance.

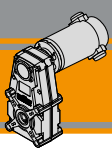

Carichi radiali

Radial loads

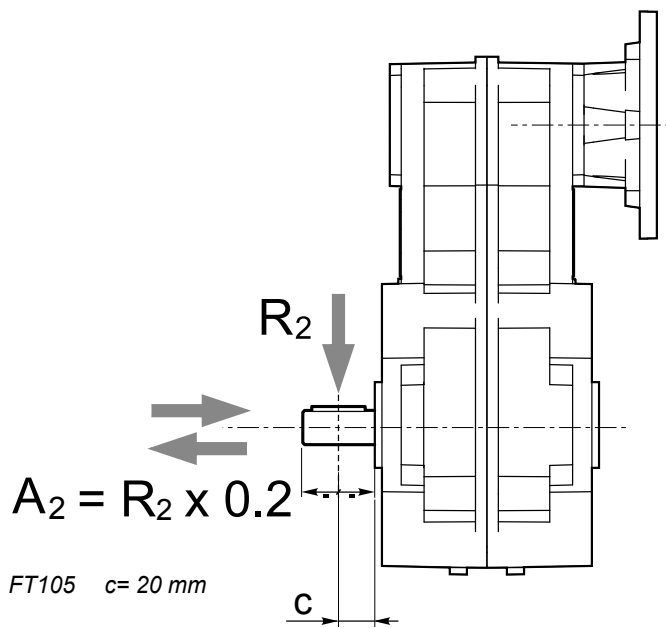

n_2 [min ⁻¹]	R_2 [N]
	FT105
70	1500
40	1700
30	1850
20	2000
10	2000
5	2000

Quando il carico radiale risultante non è applicato sulla mezzeria dell'albero occorre calcolare quello effettivo con la seguente formula:

When the resulting radial load is not applied on the centre line of the shaft it is necessary to calculate the effective load with the following formula:

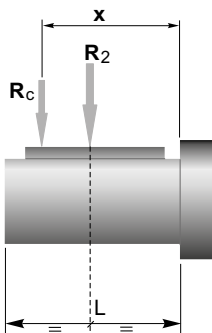



	FT105
a	82
b	62
R_{2MAX}	2000

$$R_c = \frac{R_2 \cdot a}{(b+x)} \leq R_{2MAX}$$

$$R \leq R_c$$

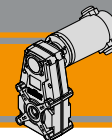
a, b = valori riportati nella tabella
a, b = values given in the table

Dati tecnici
NDFT
Technical data

P_1 [W]	n_2 [min ⁻¹]	M_2 [Nm]	sf	i		Versione motore Motor version	P_1 [W]	n_2 [min ⁻¹]	M_2 [Nm]	sf	i		Versione motore Motor version
160							250						
(3000 min ⁻¹)	146	10	3.2	20.57	120/105/3	120/240	(3000 min ⁻¹)	146	15	2.0	20.57	180/105/3	120/240
	90	16	2.4	33.32									
	68	21	2.4	44.36									
	55	26	1.9	54.87									
	42	34	1.5	71.84									
	39	37	1.4	77.07									
	34	43	1.2	88.87									
	24	60	0.8	124.81									
	17	86	0.6	181.35									
	13	86	0.6	224.32									
	9.5	86	0.6	315.05									
	8.1	86	0.6	368.19			120/105/4	120/240					
	5.6	86	0.6	534.98									
	4.5	86	0.6	661.76									
	3.2	86	0.6	929.40									



NOTA

Verificare sempre che la coppia M_2 utilizzata non ecceda il valore indicato nelle caselle in grigio

NOTE

Please check that the output torque M_2 does not exceed the value in the grey areas

Dati tecnici
ECFT
Technical data

P_1 [W]	n_2 [min ⁻¹]	M_2 [Nm]	sf	i		Versione motore Motor version	P_1 [W]	n_2 [min ⁻¹]	M_2 [Nm]	sf	i		Versione motore Motor version
100							250						
(3000 min ⁻¹)	146	6	5.1	20.57	070/105/3	12E/24E	(3000 min ⁻¹)	146	15	2.0	20.57	180/105/3	120/240
	90	10	3.9	33.32									
	68	13	3.8	44.36									
	55	16	3.1	54.87									
	42	21	2.4	71.84									
	39	23	2.2	77.07									
	34	27	1.9	88.87									
	24	37	1.4	124.81									
	17	54	0.9	181.35									
	13	67	0.8	224.32									
	9.5	86	0.6	315.05									
	8.1	86	0.6	368.19			070/105/4	12E/24E					
	5.6	86	0.6	534.98									
	4.5	86	0.6	661.76									
	3.2	86	0.6	929.40									
140													
(3000 min ⁻¹)	146	9	3.6	20.57	100/105/3	120/240/24E							
	90	14	2.8	33.32									
	68	19	2.7	44.36									
	55	23	2.2	54.87									
	42	30	1.7	71.84									
	39	32	1.6	77.07									
	34	37	1.4	88.87									
	24	52	1.0	124.81									
	16.5	76	0.7	181.35									

NOTA

Verificare sempre che la coppia M_2 utilizzata non ecceda il valore indicato nelle caselle in grigio

NOTE

Please check that the output torque M_2 does not exceed the value in the grey areas

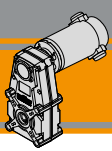

**NDFT
ECFT**

**Motoriduttori CC pendolari
DC Helical parallel gearmotors**



Motori applicabili

Motor adapters

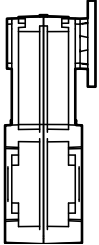
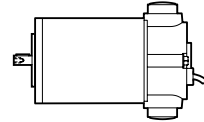
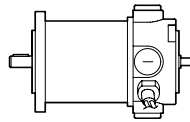

		ND		EC		
		120.120 120.240	180.120 180.240	070.12E 070.24E	100.120 100.240 100.24E	180.120 180.240
FT	105/3	20.57 - 315.05				
	105/4	368.19 - 929.4				

20.57 - 315.05

Rapporti di riduzione i
Ratio i

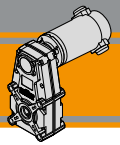

Dimensioni

Dimensions

NDFT 120/105

NDFT 120/105...U

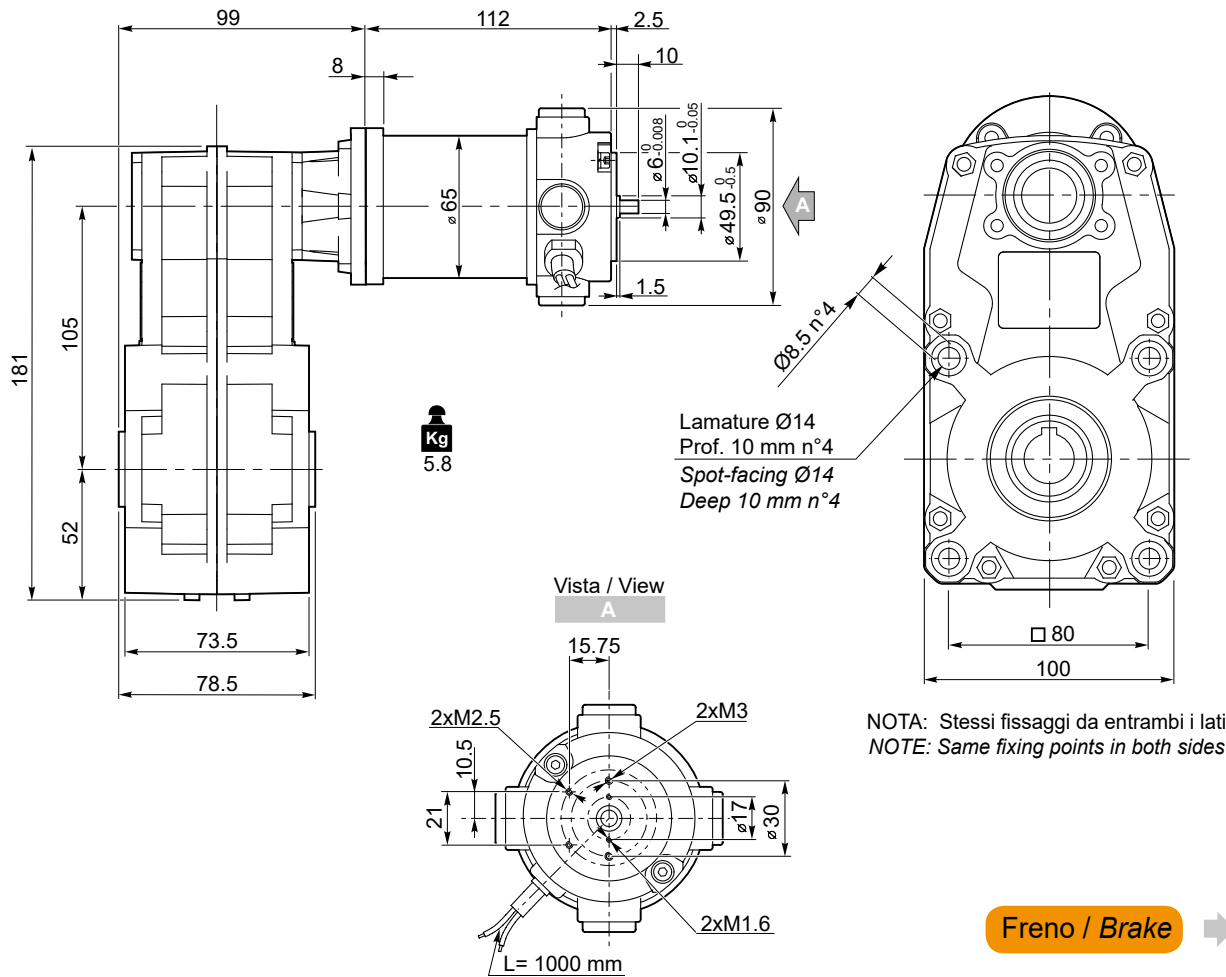

- Freno / Brake → BA9
- Encoder → BA9

O17

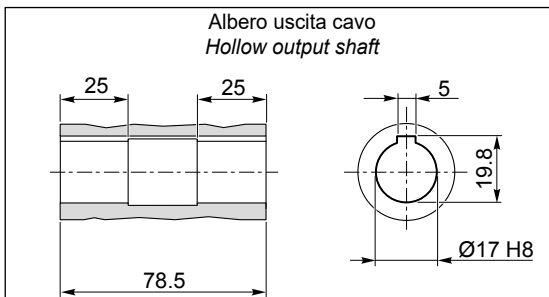

O20

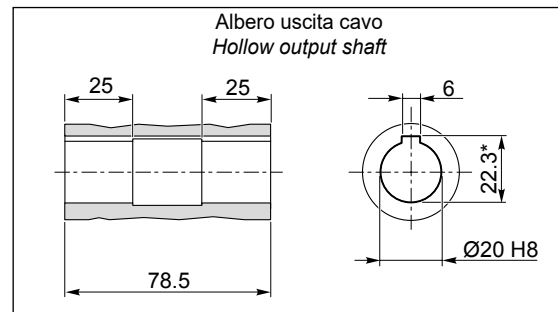

*: Sede linguetta ribassata / Special keyway

DC

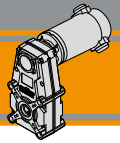

Dimensioni

Dimensions

ECFT 070/105

ECFT 070/105...U

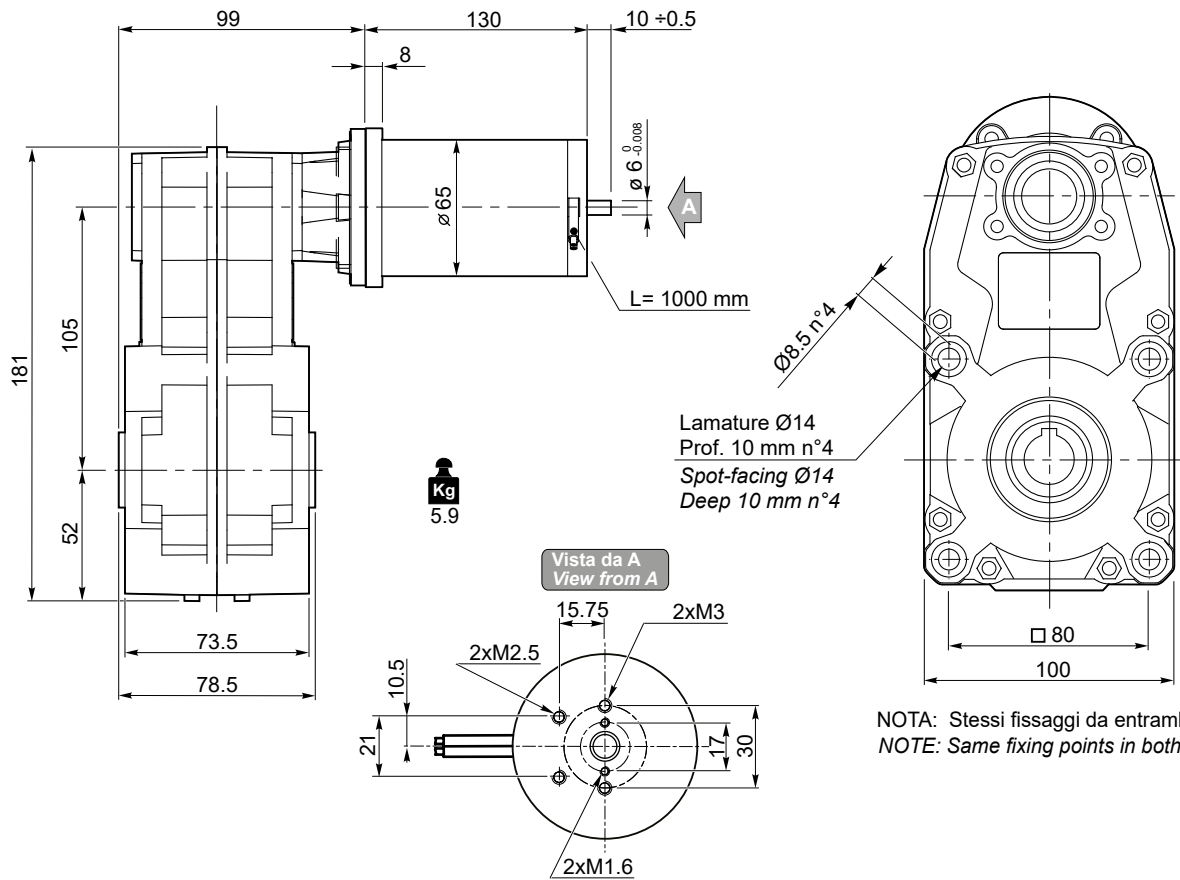

Freno / Brake → BB23

Encoder → BB24

Motori / Motors IP66 → BC2

O17

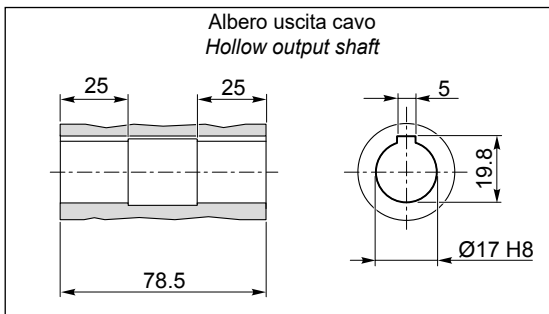

O20

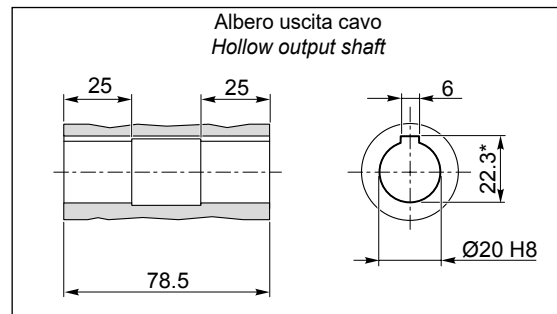

*: Sede linguetta ribassata / Special keyway

DC

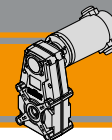

Dimensioni

Dimensions

ECFT 180/105

ECFT 180/105...U

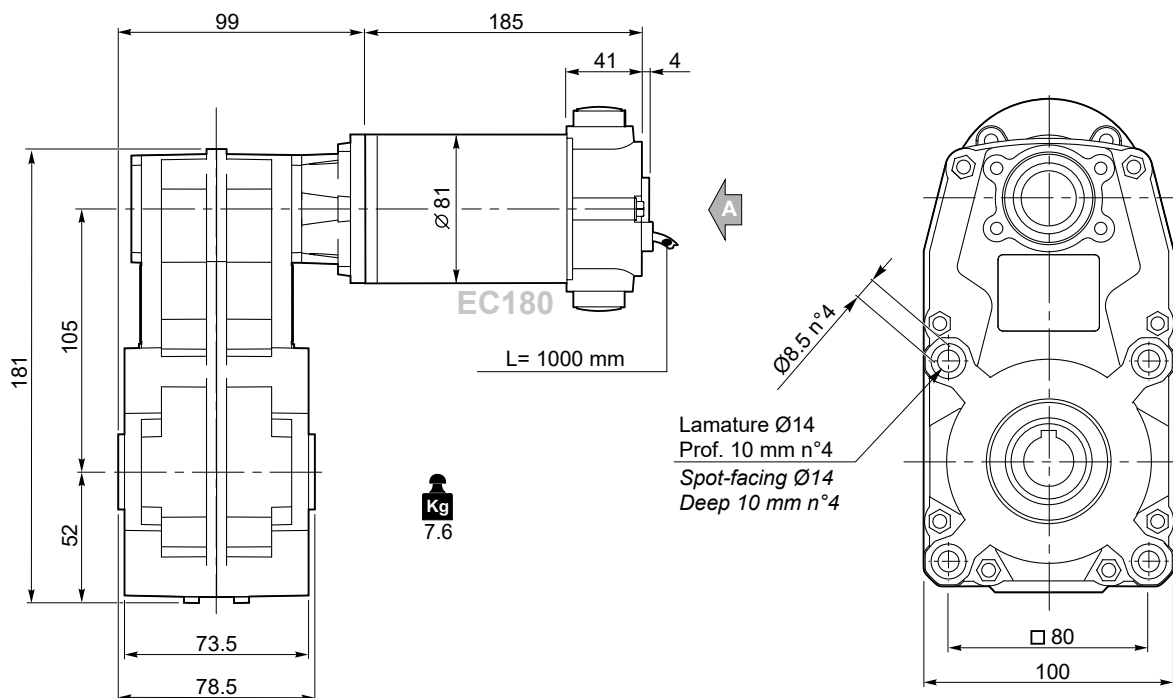

Lamature $\varnothing 14$
Prof. 10 mm n°4
Spot-facing $\varnothing 14$
Deep 10 mm n°4

NOTA: Stessi fissaggi da entrambi i lati
NOTE: Same fixing points in both sides

Freno / Brake → BB23

Encoder → BB24

Motori / Motors IP66 → BC6

O17

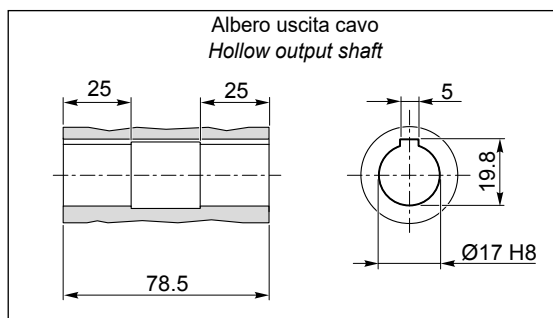

O20

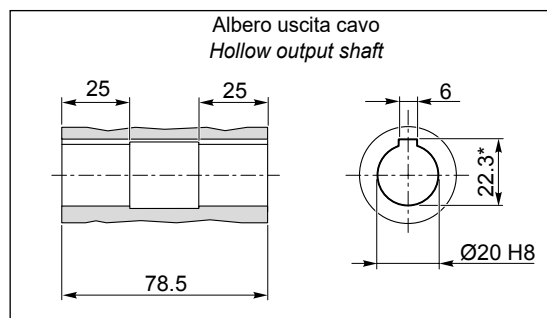

*: Sede linguetta ribassata / Special keyway

**MA TRANSTECNO S.A.P.I. DE C.V.**

Av. Mundial # 176, Parque Industrial
JM Apodaca, Nuevo León,
C.P. 66600
MÉXICO
T +52 8113340920
info@transtecno.com.mx
www.transtecno.com.mx

**TRANSTECNO SRL**

Via Caduti di Sabbiuino, 11/D-E
40011 Anzola dell'Emilia (BO)
ITALY
T+39 051 64 25 811
F +39 051 73 49 43
sales@transtecno.com
www.transtecno.com

**HANGZHOU TRANSTECNO POWER TRANSMISSIONS CO LTD**

No.4 Xiuyan Road Fengdu Industry Zone
Pingyao Town Yuhang District
Hangzhou City, Zhejiang Province
311115 – CHINA
T +86 571 86 92 02 60
F +86 571 86 92 18 10
info-china@transtecno.com
www.transtecno.cn

**TRANSTECNO U.S.A. LLC**

5440 S.W. 156th Place Miami,
FL 33185 - USA
Tel: +1 (305) 220-4423
Fax: +1 (305) 220-5945
usaoffice@transtecno.com

**TRANSTECNO B.V.**

Ind. terrein Wieken/Vinkenhoef
De Stuwdam,43
3815 KM Amersfoort - NETHERLANDS
Tel: +31(0) 33 45 19 505
Tel: +31(0) 33 45 19 506
info@transtecno.nl
www.transtecno.nl

**SALES OFFICE INDIA**

A/10, Anagha, S.N. Road, Mulund (W) Mumbai
400080 - INDIA
Tel: +91 9820614698
Fax-Italy: +39 051 73 49 43
indiaoffice@transtecno.com

**SALES OFFICE BRAZIL**

Rua Dr. Freire Alemão 155 / 402 - CEP. 90450-060
Auxiliadora Porto Alegre RS - BRAZIL
Tel: +55 51 3251 5447
Fax: +55 51 3251 5447
Mobile: +55 51 811 45 962
braziloffice@transtecno.com
www.transtecno.com.br

**TRANSTECNO AANDRIJFTECHNIEK B.V.**

De Stuwdam 43
3815 KM Amersfoort - NETHERLANDS
Tel: +31 (0) 33 20 4 7 006
info@transtecnoaandrijftechniek.nl
www.transtecnoaandrijftechniek.nl

**SALES OFFICE SOUTH KOREA**

D-304 Songdo BRC Smart Valley 30, Songdomirae-ro,
Yeonsu-gu, Incheon, 406-840 - KOREA
Tel: +82 70 8288 2107
Fax: +82 32 815 2107
Mobile: +82 10 5094 2107
koreaoffice@transtecno.com

**TRANSTECNO IBÉRICA****THE MODULAR GEARMOTOR, S.A.**

C/Enginy, 2 Nave 6 - 08850 Gavà (Barcelona) - SPAIN
Tel: +34 931 598 950
info@transtecno.es
www.transtecno.es

**SALES OFFICE OCEANIA**

44 Northview drive, Sunshine west 3020
Victoria - AUSTRALIA
Ph +61 03 9312 4722
Fax +61 03 9312 4714
Mobile: +61 0438060997
oceaniaoffice@transtecno.com
www.transtecno.com.au

**SALES OFFICE FRANCE**

Tel: +33 (0) 6 85 12 09 87
Fax-Italy: +39 051 73 49 43
franceoffice@transtecno.com
www.transtecno.fr



www.transtecno.com