

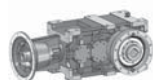

700 Series



800 Series

RXO-V/700/EST

RXO-V/800/EST

REDUTTORI- MOTORIDUTTORI ORTOGONALI PER ESTRUSORI
EXTRUDER HELICAL BEVELGEARBOXES AND GEARED MOTORS
KEGELRADGETRIEBE - KEGELRADGETRIEBEMOTOREN FÜR
EXTRUDER

1.1	Caratteristiche costruttive	<i>Construction features</i>	Konstruktionsmerkmale	B3
1.2	Livelli di pressione sonora SPL [dB(A)]	<i>Mean sound pressure levels SPL [dB(A)]</i>	Schalldruckpegel SPL [dB(A)]	B4
1.3	Criteri di selezione	<i>Gear unit selection</i>	Auswahlkriterien	B5
1.4	Verifiche	<i>Verification</i>	Überprüfungen	B6
1.5	Stato di fornitura	<i>Scope of the supply</i>	Lieferzustand	B16
1.6	Normative applicate	<i>Standards applied</i>	Angewendete Normen	B18
1.7	Designazione	<i>Designation</i>	Bezeichnung	B22
1.8	Lubrificazione	<i>Lubrication</i>	Schmierung	B32
1.9	Prestazioni riduttori	<i>Gear unit ratings</i>	Leistungen der Getrieben	B38
1.11	Dimensioni	<i>Dimensions</i>	Applizierbare Motoren	B44

STM RXO-V - EST - Extruder Application

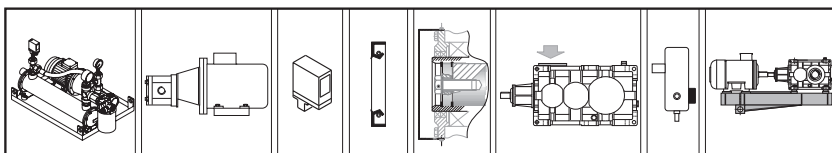

Accessori e opzioni
Accessories and options
Zubehör und Optionen

Gestione Revisione Cataloghi GSM
Managing GSM Catalog Revisions
Management Wiederholt Kataloge GSM

SIMBOLO SYMBOL SYMBOL	DEFINIZIONE	DEFINITION	DEFINITION	UNITA' DI MISURA MEASUREMENT UNIT MAßEINHEIT	
fa	Fattore correttivo dell'altitudine	Altitude factor	Höhenkorrekturwert		
Fa₁₋₂	Carico assiale	<i>Axial load</i>	Axialbelastung	N	1N=0.1daN ≅ 0.1kg
fc	Coefficiente relativo alla temperatura dell'aria	Air temperature factor	Koeffizient bezüglich der Lufttemperatur		
fd	Fattore correttivo del tempo di lavoro	Operation time factor	Korrekturfaktor der Arbeitszeit		
ff	Fattore correttivo di aerazione con ventola	Fan cooling factor	Korrekturfaktor der Belüftung durch Lüfter		
f_{Ga}	Fattore di affidabilità	Safety factor	Zuverlässigkeitsfaktor		
fm	Fattore correttivo per la posizione di montaggio	Mounting position factor	Korrekturfaktor für einbaulage		
f_n	Fattore correttivo delle prestazioni	Input speed factor	Korrekturfaktor der Leistungen		
fp	Fattore correttivo della temperatura	Ambient temperature factor	Korrekturfaktor der Umgebungstemperatur		
Fr₁₋₂	Carico Radiale	<i>Radial load</i>	Radialbelastung	N	1N=0.1daN ≅ 0.1kg
Fs	Fattore di servizio	<i>Service factor</i>	Betriebsfaktor		
Fs'	Fattore di servizio riduttore	<i>Gearbox service factor</i>	Betriebsfaktor Getriebe		
fv	Fattore correttivo	Duty cycle factor	Korrekturfaktor		
fw	Coefficiente relativo alla temperatura dell'acqua	Water temperature factor	Koeffizient bezüglich der Wassertemperatur		
IEC	Motori accoppiabili	<i>Motor options</i>	Passende Motoren		
ir	Rapporto di trasmissione	<i>Ratio</i>	Übersetzungsverhältnis		
J	Momento d'inerzia della macchina e del riduttore ridotto all'asse motore	Machine and gear unit inertial load reflected to motor shaft	An der Motorachse reduziertes Trägheitsmoment der Maschine und des Getriebe	Kgxm²	
J₀	Momento d'inerzia delle masse rotanti sull'asse motore	Inertial load of rotating parts at motor shaft	Trägheitsmoment der an der Motorachse drehenden Massen	Kgxm²	
kg	Massa	<i>Mass</i>	Masse	kg	
n₁	Velocità albero entrata	<i>Input speed</i>	Antriebsdrehzahl	min⁻¹	1 min ⁻¹ = 6.283 rad.
n₂	Velocità albero in uscita	<i>Output speed</i>	Abtriebsdrehzahl	min⁻¹	1 min ⁻¹ = 6.283 rad.
P	Potenza motore	<i>Gear unit power</i>	Leistung Getriebe	kW	
P'	Potenza richiesta in uscita	<i>Output power</i>	Erforderliche Abtriebsleistung	kW	
P₁	Potenza motoriduttore	<i>Gear motor power</i>	Leistung Getriebemotor	kW	1kW = 1.36 HP (PS)
P_c	Potenza corretta	<i>Correct power</i>	Tatsächliche Leistung	kW	
P_N	Potenza nominale	Nominal power	Nennleistung	kW	
P_{ta}	Potenza termica addizionale	Additional thermal power	Thermische Zusatzgrenzleistung	kW	
P_{tN}	Potenza termica nominale	Thermal power rating	Termische Nenngrenzleistung	kW	
P_{t0}	Potenza limite termico	<i>Limit thermal capacity</i>	Thermische Leistungsgrenze	kW	
RD (η)	Rendimento dinamico	<i>Dynamic efficiency</i>	Dynamischer Wirkungsgrad		
RS	Rendimento statico	<i>Static efficiency</i>	Statischer Wirkungsgrad		
T_{1f}	Coppia frenante dinamica	Dynamic braking torque	Dynamisches Bremsmoment	Nm	
T_{1max}	Coppia motrice massima	Max drive torque	Max. Antriebsmoment	Nm	
T_{1s}	Coppia motrice di spunto	Starting torque	Anlaufantriebsdrehmoment	Nm	
T_c	Temperatura ambiente	<i>Ambient temperature</i>	Umgebungstemperatur	°C	
T_N	Coppia nominale	Nominal torque	Nenndrehmoment	Nm, kNm	
T_{Tbr}	Coppia frenatura motore Autofrenante	Motor braking torque	Motorbremsmoment	Nm, kNm	
T_{1a}	Coppia limite in ingresso del dispositivo antiretro	income limit torque for back-stop device	Grenzantriebsmoment der Rücklaufsperr	Nm, kNm	
Q_{rid}	Quantità olio di riempimento del riduttore	Gearbox oil quantity	Öfüllmenge des Getriebes		
Q_{min}	Quantità olio minima	Minimum tank oil	Minimale Öfüllung im Tank	Nm, kNm	
M_{2s}	Coppia di slittamento calettatore	Shrink disc slipping torque	Schrumpfscheiben-Schlupfmoment	Nm, kNm	



RXO-V/700/EST

700 Series

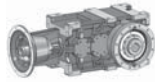

RXO-V/800/EST

800 Series

RIDUTTORI - MOTORIDUTTORI ORTOGONALI PER
ESTRUSORI
EXTRUDER HELICAL BEVELGEARBOXES AND
GEARED MOTORS KEGELRADGETRIEBE -
KEGELRADGETRIEBEMOTOREN FÜR EXTRUDER

RXO-V
EST

STM
team

700 Series

RX01-RXV1

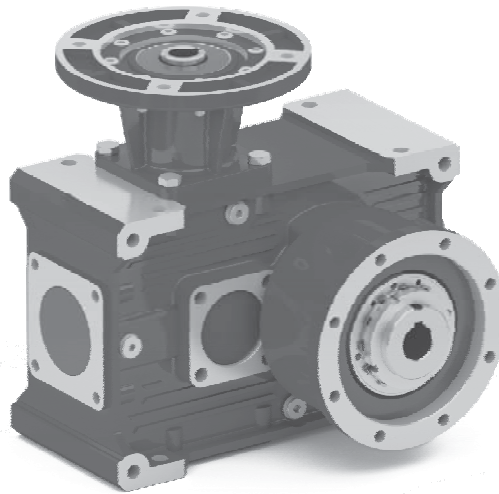

STM
team

800 Series

RX02-RXV2

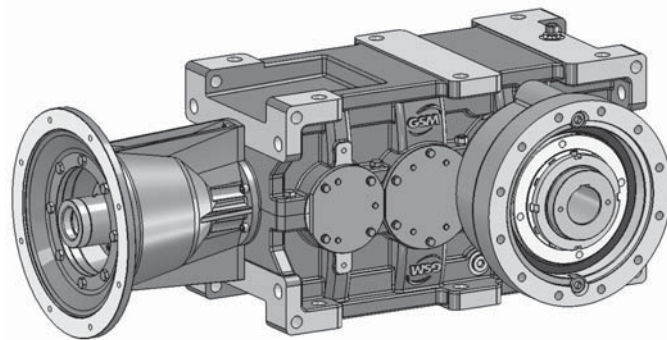

RX 700 - 800: Questa nuova serie di riduttori per il comando di estrusori monovite, mantiene la nostra azienda ai vertici del mercato nella trasmissione di coppia, riuscendo a coprire da un diametro di vite 30mm fino ad oltre 300mm (da 220mm a richiesta) RXO-V/EST è una macchina con caratteristiche innovative avente estrazione vite anteriore e cuscinetto reggispinta alloggiato nella flangia: la massima integrazione fra azionamento ed estrusore imbattibile nel rapporto qualità/prezzo.

Data la continua evoluzione di questo settore, la nostra azienda è costantemente impegnata nella ricerca e sviluppo di nuove soluzioni da proporre ai clienti.

RX 700 - 800: This new gearboxes series for single screw extruder control, has consolidated the position of our company at the market top for transmittable moment torque.

RXO-V/EST is a machine intended to be very innovative by having screw front extraction and thrust hold bearing on flanged mounting.

In this way we can reach the highest integration between drive and extrusion leading to an unbeatable ratio quality/price.

We can to cover the extruder diameter screw from 30mm to up 300mm (from 220mm on request).

As this sector is continual evolution, our company is constantly researching and developing new solutions for the customers.

RX 700 - 800: Diese neue Getriebereihe für Einschneckenextruder, macht unser Unternehmen zu einem der Marktführer im Bereich Drehmomentübertragung, da wir einen Schneckendurchmesser von 30mm bis über 300mm (ab 220mm auf Anfrage) abdecken können.

RXO-V / EST ist eine Maschine mit innovativen Features, ausgestattet mit Frontschneckenextraktion und im Flansch untergebracht Drucklager: die bestmögliche Kombination aus Antrieb und Extruder, unschlagbar im Verhältnis Qualität / Preis.

Angesichts der ständigen Weiterentwicklung dieser Branche, ist unser Unternehmen kontinuierlich in der Forschung und Entwicklung engagiert, um den Kunden stets neue Lösungen vorschlagen zu können.

1.1 Caratteristiche costruttive

Generalità

Le dimensioni dei nostri riduttori e i rapporti di trasmissione seguono la serie dei numeri normali (serie di RENARD) Ra 20 UNI 2016.68.

L'elevato numero di rapporti di trasmissione RX 700 - $i_N = (5.2 \div 75.4)$ - RX 800 - $i_N = (19.10 \div 124)$, consente in alcuni casi di scegliere un riduttore di taglia inferiore.

L'ottimizzazione geometrica dell'ingranaggio unitamente ad una accurata lavorazione, assicura bassi livelli di rumorosità e garantisce elevati rendimenti:

1.1 Construction features

General description

Gear unit dimensions and transmission ratios follow a geometric progression based on the Ra20 series of preferred (or Renard) numbers in accordance with UNI 2016.68.

Our broad range of transmission ratios RX 700 - $i_N = (5.2 \div 75.4)$ - RX 800 - $i_N = (19.10 \div 124)$ and high ratio density frequently allows selection of a smaller size.

Optimal gear geometry and high machining accuracy ensure low noise levels and higher efficiency:

1.1 Konstruktionsmerkmale

Allgemeines

Die Baugrößen und Übersetzungen unserer Getriebe sind der normalen Nummernserie (RENARD Reihe) Ra 20 UNI 2016.68 gemäß ausgelegt.

Die zahlreichen Übersetzungsverhältnisse RX 700 - $i_N = (5.2 \div 75.4)$ - RX 800 - $i_N = (19.10 \div 124)$ räumen in einigen Fällen die Möglichkeit ein, ein kleineres Getriebe wählen zu können.

Die geometrische Optimierung des Zahnrads verbunden mit einer akkuraten Bearbeitung gewährleistet niedrige Geräusentwicklung und einen hohen Wirkungsgrad:

Stadi/Stages/Stufig	Riduttore/Gearbox/Getriebe	RD (%) Rendimento/Efficiency/Wirkungsgrad
2	RXO-V 1	95
3	RXOV 2	93

1.2 Livelli di pressione sonora SPL [dB(A)]

Valori normali di produzione del livello medio di pressione sonora SPL (dB(A)) a velocità in entrata di 1450 min⁻¹ (tolleranza +3 dB(A)). Valori misurati ad 1 m dalla superficie esterna del riduttore ed ottenuti su elaborazione di prove sperimentali eseguite. Per raffreddamento artificiale con ventola sommare ai valori di tabella: +2 dB(A) per ogni ventola. Per entrata ad un numero di giri diverso sommare i valori come in tabella.

Per particolari esigenze è possibile fornire riduttori con livello medio di pressione sonora ridotto.

1.2 Mean sound pressure levels SPL [dB(A)]

Noise levels are mean sound pressure levels SPL (dB(A)) and refer to normal operation at an input speed of 1450 rpm (tolerance +3 dB(A)). Measurements are taken at 1 m from the external surface of the gear unit and ratings are obtained by processing test data.

For fan-cooled applications, add 2dB(A) to table values for each fan. For different input speeds, add the appropriate values indicated in the table below.

Gear units with lower noise levels to suit particular needs are available on request.

1.2 Schalldruckpegel SPL [dB(A)]

Normale Werte des durchschnittlichen Schalldruckpegels SPL (dB(A)) bei einer Antriebsdrehzahl von 1450 U/min (Toleranz +3 dB(A)). Werte, die aus den Auswertungen der erfolgten experimentellen Tests, bei denen die Messung in 1 m Entfernung von der Getriebeoberfläche erfolgte, resultieren.

Bei Vorliegen einer Zusatzluftkühlung durch Lüfter muss ein Korrekturwert von +2 dB(A) pro Lüfterrad zum Tabellenwert addiert werden. Bei abweichender Antriebsdrehzahl sind die Werte gemäß Tabellenangaben zu addieren.

Im Fall besonderer Anforderungen können Getriebe mit einem reduzierten durchschnittlichen Schalldruckpegel geliefert werden.

		RXO1
RX 700 Series	700	Valori indicativi massimi 75 dB(A) / Maximum approximate value of 75 dB(A) / Max. Anhaltswerte 75 dB (A)

		RXO2 - RXV2	
		i ≤ 50	i > 50
RX 800 Series	802	75	70
	804	76	71
	806	78	73
	808	79	74
	810	81	76
	812	82	77
	814	84	79
	816	86	81
	818	88	83
	820	90	85

n ₁ [min ⁻¹]	2750	2400	2000	1750	1000	750	500	350
Δ SPL [dB(A)]	8	6	4	2	-2	-3	-4	-6

1.3 Criteri di selezione

Conosciuti i dati dell'applicazione calcolare:

$$ir = n_1/n_2;$$

$$P1 = \frac{T_{2n} \times n_2 \times 100}{9550 \times RD\%};$$

n_1 - Velocità albero entrata;
 n_2 - Velocità albero uscita;
 ir - Rapporto di trasmissione;
 $RD\%$ - Rendimento dinamico;
 $P1$ - Potenza macchina motrice;
 T_{2n} - Coppia Uscita Nominale Applicazione

Per selezionare il riduttore è necessario che sia soddisfatta la seguente relazione:

1.3 Gear unit selection

Locate application information and determine:

$$ir = n_1/n_2;$$

$$P1 = \frac{T_{2n} \times n_2 \times 100}{9550 \times RD\%};$$

n_1 - Input shaft speed;
 n_2 - Output shaft speed;
 ir - Ratio;
 $RD\%$ - Dynamic efficiency;
 $P1$ - Input power;
 T_{2n} - Application nominal output torque

For gearbox selection the following is necessary:

1.3 Auswahlkriterien

Sind die Daten der Anwendung bekannt, ist wie folgt zu kalkulieren:

$$ir = n_1/n_2;$$

$$P1 = \frac{T_{2n} \times n_2 \times 100}{9550 \times RD\%};$$

n_1 -Drehzahl Antriebswelle;
 n_2 - Drehzahl Abtriebswelle;
 ir - Übersetzung;
 $RD\%$ - Dynamischer Wirkungsgrad;
 $P1$ - Antriebsleistung;
 T_{2n} - Effektivmoment

Für die Getriebeauswahl ist folgendes zu beachten:

Potenza
Power
Leistung

$$P_N \times fn \geq P_1 \times Fs$$

Coppia
Torque
Drehmoment

$$T_N \times fn \geq T_{2n} \times Fs$$

Il valore di T_N è riportato nelle schede tecniche di prodotto.
 Le potenze e i momenti torcenti indicati a catalogo nominali sono validi per $Fs=1$.

Fs - fattore di Servizio
 fn - Fattore correttivo delle prestazioni

Scegliere gli stadi, il rapporto, la grandezza, l'esecuzione, la forma costruttiva e verificare le dimensioni del riduttore e di eventuali accessori o particolari estremità.

The T_N value is write on the product technical sheets.
 Power and torque ratings stated in the catalogue refer to service factor $Fs=1$.

Fs - Service factor
 fn - Input speed factor

Select number of stages, ratio, size, shaft arrangement and design configuration and then check the dimensions of gear unit and any accessories or particular input/output configurations you have selected.

Den Wert von T_N finden sie auf den technischen Produkt-Datenblättern
 Die im Katalog angegebenen Nennleistungen und -drehmomente sind für $Fs=1$ gültig.

Fs - Betriebsfaktor
 fn - Korrekturfaktor der leistungen

Die Stufen, Übersetzung, Größe, Ausführung sowie Bauform wählen und die Größe des Getriebes und des eventuellen Zubehörs oder besondere Wellenenden überprüfen.



1.3 Criteri di selezione

Fattore di servizio - Fs

Il fattore di Servizio Fs dipende:

- a) dalle condizioni di applicazione
- b) dalla durata di funzionamento h/d
- c) avviamenti /ora
- d) dal grado di affidabilità o margine di sicurezza voluto .

Il fattore di servizio assunto per riduttori per estrusione è generalmente $F_s = 1.5$. Dove il funzionamento è continuo sino ad arrivare a due o tre turni giornalieri il fattore di servizio è rispettivamente $F_s = 1.75$ e $F_s = 2$. Le potenze e i momenti torcenti indicati a catalogo nominali sono validi per $F_s=1$.

1.3 Gear unit selection

Service factor - Fs

Service factor F_s is determined on the basis of:

- a) operating conditions of application
- b) operation per day (h/d)
- c) starts and stops per hour
- d) desired reliability or safety factor.

Usually, a service factor $F_s=1.5$ is selected for extruder gear units. Service factors for continuous duty up to two or three daily shifts are $F_s=1.75$ and $F_s = 2$, respectively. Power and torque ratings stated in the catalogue refer to service factor $F_s=1$.

1.3 Auswahlkriterien

Betriebsfaktor - Fs

Der Betriebsfaktor F_s hängt von folgenden Kriterien ab:

- a) Einsatzbedingungen
- b) Betriebsdauer h/d
- c) Anläufe / Stunde
- d) Zuverlässigkeitsgrad oder gewünschter Sicherheitsbereich.

Der für die in der Extrusion eingesetzten Getriebe angesetzte Betriebsfaktor ist allgemein $F_s = 1.5$.

In Fällen, in denen ein Dauerbetrieb, bis zwei und drei Tagesschichten, vorgesehen ist, entspricht der Betriebsfaktor jeweils $F_s = 1.75$ und $F_s = 2$.

Die im Katalog als Nennwerte angegebenen Leistungen und Drehmomente sind für $F_s = 1$ gültig.

fn

Fattore correttivo delle prestazioni
Input speed factor
Korrekturfaktor der Leistungen

Fattore correttivo delle prestazioni nominali per tenere conto delle velocità in entrata $n_1 > 1450 \text{ min}^{-1}$

This correction factor is used to adjust performance ratings to account for input speeds $n_1 > 1450 \text{ min}^{-1}$

Korrekturfaktor der Nennleistungen unter Berücksichtigung der Eingangsdrehzahlen $n_1 > 1450 \text{ min}^{-1}$

fn	RX 700 Series	1.0	Il valore di T_N (2850 rpm) è riportato nelle schede tecniche di prodotto The T_N (2850 rpm) value is write on the product technical sheets Den Wert von T_N (2850 rpm) finden sie auf den technischen Produkt-Datenblättern					
fn	RX 800 Series	n_1 [min^{-1}]	$i_N \leq 8$		$8 < i_N < 80$		$i_N \geq 80$	
			T_N	P_N	T_N	P_N	T_N	P_N
		2750	0.82	1.56	0.90	1.71	1.00	1.90
		2400	0.85	1.41	0.92	1.52	1.00	1.66
		2000	0.90	1.24	0.94	1.30	1.00	1.38
		1750	0.94	1.13	0.97	1.17	1.00	1.21
1450	1.00	1.00	1.00	1.00	1.00	1.00		

1.4 Verifiche

01 1) Compatibilità dimensionale con ingombri disponibili, estremità di entrata e di uscita.

02 2) Adeguatezza del rapporto di trasmissione.

03 3) Massimo sovraccarico nel caso di:
- inversioni di moto per effetti inerziali,
- commutazioni da bassa ad alta polarità,
- avviamenti e frenature a pieno carico con grandi momenti d'inerzia (soprattutto nel caso di bassi rapporti),
- sovraccarichi, urti od altri effetti dinamici,

1.4 Verification

1) Ensure that dimensions are compatible with space constraints and input and output configuration.

2) Ensure that transmission ratio is suitable for the application:

3) Determine maximum overload in the event of:
- reversing due to inertia,
- switching from low to high polarity,
- starts and stops under full load with high moment of inertia (this is especially important for low ratios),
- overload, shock load or other dynamic load conditions

1.4 Überprüfungen

1) Kompatibilität der Abmessungen mit verfügbaren Maßen und der Wellenenden mit den Kupplungen, Scheiben oder Riemenscheiben.

2) Angemessenheit des Übersetzungsverhältnisses.

3) Maximale Überlast im Fall von:

- Drehrichtungs-Umkehr aufgrund von Trägheitseffekten,
- Umschaltung von niedriger auf hohe Polarität,
- Anläufe und Bremsungen unter Vollast mit hohen Trägheitsmomenten (vor allem bei niedrigen Übersetzungsverhältnissen),
- Überlasten, Stöße oder andere dynamische Effekte.

1.4 Verifiche

1.4 Verification

1.4 Überprüfungen

Nel caso di avviamenti T_{2max} può essere considerata come quella parte della coppia accelerante (T_{2acc}) che passa attraverso l'asse lento del riduttore:

For starting, T_{2max} may be considered as that portion of acceleration (T_{2acc}) passing through the gear unit output (low speed) shaft:

Bei Anläufen kann T_{2max} als der Teil des Beschleunigungsmoments (T_{2acc}), der durch die Abtriebsachse des Getriebes läuft, angesehen werden:

Avviamento

Starting

Anlauf

$$T_{2max} = T_{2acc} = \left((0.45 \cdot (T_{1s} + T_{1max}) \cdot ir \cdot \eta) - T_{2n} \right) \cdot \left(\frac{J}{J + J_0 \cdot \eta} \right) + T_{2n} \quad [Nm]$$

dove:

J: momento d'inerzia della macchina e del riduttore ridotto all'asse motore (kgm^2)
 J_0 : momento d'inerzia delle masse rotanti sull'asse motore (kgm^2)
 T_{1s} : coppia motrice di spunto (Nm)
 T_{1max} : coppia motrice max (Nm)

Where:

J: machine and gear unit inertial load reflected to motor shaft (kgm^2)
 J_0 : inertial load of rotating parts at motor shaft (kgm^2)
 T_{1s} : starting torque (Nm)
 T_{1max} : max drive torque (Nm)

Hier ist:

J: An der Motorachse reduziertes Trägheitsmoment der Maschine und des Getriebes (kgm^2)
 J_0 : Trägheitsmoment der an der Motorachse drehenden Massen (kgm^2)
 T_{1s} : Anlaufantriebsdrehmoment (Nm)
 T_{1max} : Max. Antriebsmoment (Nm)

E' necessario che sia soddisfatta la seguente relazione:

The following formula must be satisfied:

Folgende Bedingung muss erfüllt sein:

$$T_{2max} < 2xT_N$$

04 4) Numero massimo di giri in entrata n_{1max}

4) Check maximum input speed n_{1max}

4) Max. Antriebsdrehzahl n_{1max}

RX 700 Series

Tutte le prestazioni dei riduttori sono calcolate in base a 2850, 1450, 1000 e 500 giri in entrata.

Velocità inferiori a 1400 min⁻¹ ottenute con l'ausilio di riduzioni esterne o di azionamenti, sono sicuramente favorevoli al buon funzionamento del riduttore, il quale può operare con temperature di funzionamento inferiori a vantaggio di tutto il cinematismo.

Per velocità inferiori a 900 min⁻¹ consultare il nostro Servizio Tecnico Commerciale.

All performances of geraboxes are calculated according to 2850, 1450, 1000 and 500 input rpm.

Speeds lower than 1400 min⁻¹ obtained by means of external reductions or drives, surely contribute to the good working of the gearbox which can operate at lower working temperatures to the advantage of the whole kinematic movement.

In case of input speed below 900 min⁻¹ please refer to our Technical Commercial Office.

Alle Leistungen der Getriebe werden auf der Grundlage folgender Antriebsdrehzahlen berechnet: 2850, 1450, 1000 und 500 min⁻¹. Drehzahlen unter 1400 min⁻¹, die mit Hilfe äußerer Untersetzungen oder Antriebe erhalten werden, sind für den optimalen Betrieb des Getriebes vorteilhaft, denn so kann dieses mit niedrigen Betriebstemperaturen arbeiten, was sich zum Vorteil der gesamten Getriebegruppe auswirkt.

Für Geschwindigkeiten unter 900 min⁻¹ wenden sie sich bitte an unsere Technische Abteilung.

RX 800 Series

n ₁ max (rpm)	ir	802		804		806		808		810		812		814		816		818		820	
		splash oil	forced lubric.	splash oil	forced lubric.	splash oil	forced lubric.	splash oil	forced lubric.	splash oil	forced lubric.	splash oil	forced lubric.	splash oil	forced lubric.	splash oil	forced lubric.	splash oil	forced lubric.	splash oil	forced lubric.
RX02	19-54.6	3500	3500	3500	3500	3500	3500	3500	3500	3500	3500	2900	3500	2900	3500	2500	2900	2500	2900	2000	2500
RXV2	54.6-130.5																				2900

1.4 Verifiche

05 5) Verifica carichi radiali e assiali

RX 700 Series

Quando la trasmissione del moto avviene tramite meccanismi che generano carichi radiali sull'estremità

dell'albero, è necessario verificare che i valori risultanti non eccedano quelli indicati nelle tabelle delle prestazioni.

Come carico assiale ammissibile contemporaneo si ha:

$$F_{a1} = 0.2 \times Fr_1$$

I carichi radiali indicati nelle tabelle si intendono applicati a metà della sporgenza dell'albero standard e sono riferiti ai riduttori operanti con fattore di servizio 1. Per le sporgenze fornite in alternativa, fare riferimento alla sporgenza standard.

Valori intermedi relativi a velocità non riportate possono essere ottenuti per interpolazione considerando però che Fr_1 a 500 min^{-1} rappresentano i carichi massimi consentiti.

Per i carichi non agenti sulla mezzeria dell'albero lento o veloce si ha:

a 0.3 della sporgenza:

$$F_{rx} = 1.25 \times Fr_1$$

a 0.8 dalla sporgenza:

$$F_{rx} = 0.8 \times Fr_1$$

Calcolo Fr

Per calcolare il carico Fr agente sull'albero veloce o lento diamo formule approssimate per alcune trasmissioni più comuni, per la determinazione del carico radiale su albero veloce o lento.

1.4 Verification

5) Overhung and thrust load verification

Should transmission movement determine radial loads on the angular shaft end, it is necessary to make sure that resulting values do not exceed the ones indicated in the tables.

Contemporary permissible axial load is given by the following formula:

$$F_{a1} = 0.2 \times Fr_1$$

The radial loads shown in the tables are applied on the centre line of the standard shaft extension and are related to gearboxes working with service factor 1. With reference to alternative values of shaft extension, refer to standard shaft extension.

Intermediate values of speeds that are not listed can be obtained through interpolation but it must be considered that Fr_1 at 500 min^{-1} represent the maximum allowable loads.

For loads which are not applied on the centre line of the output or input shaft, following values will be obtained:

at 0.3 from extension:

$$F_{rx} = 1.25 \times Fr_1$$

at 0.8 from extension:

$$F_{rx} = 0.8 \times Fr_1$$

Fr calculation

Use the formula and the approximate factors for input or output overhung load determination referred to the most common drive members to calculate Fr load at output shaft.

1.4 Überprüfungen

5) Überprüfung der Radial- und Axialkräfte

Wird das Wellenende auch durch Radialkräfte belastet, so muß sichergestellt werden, daß die resultierenden Werte die in der Tabelle angegebenen nicht überschreiten.

Die Axialbelastung beträgt dann:

$$F_{a1} = 0.2 \times Fr_1$$

Bei den in der Tabelle angegebenen Radialbelastungen wird eine Krafteinwirkung auf die Mitte des Wellenendes zugrunde gelegt; außerdem arbeiten die Getriebe mit Betriebsfaktor 1. Bei Einsatz von Sonderabtriebswellen beziehen Sie sich bitte auf die oben aufgeführten Abstände der Standardabtriebswellen.

Zwischenwerte für nicht aufgeführte Drehzahlen können durch Interpolation ermittelt werden. Hierbei ist jedoch zu berücksichtigen, daß der maximale Wert für Fr_1 bei 500 min^{-1} gilt.

Bei Lasten, die nicht auf die Mitte der Ab- und Antriebswellen wirken, legt man folgende Werte zugrunde:

0.3 vom Wellenabsatz entfernt:

$$F_{rx} = 1.25 \times Fr_1$$

0.8 vom Wellenabsatz entfernt:

$$F_{rx} = 0.8 \times Fr_1$$

Berechnung der Fr

Für die Berechnung der an der Abtriebswelle oder Antriebswelle wirkenden Belastungen Fr geben wir approximative Formeln an, die für einige der allgemeinen Antriebsformen zum Bestimmen der auf die An- oder Abtriebswelle einwirkenden Radialkraft verwendet werden kann.

$Fr = k \cdot \frac{T}{d}$	Fr [N] Carico radiale approssimato Approximate overhung load Approx. Wert - Radialkraft	d [mm] Diametro pulegge, ruote Pulley diameter, wheels Durchmesser Räder, Riemenscheiben	k Fattore di collegamento Connection factor Anschlusswert	T [Nm] Momento torcente Torque Drehmoment	
k =	7000	5000	3000	2120	2000
Trasmissioni Drive member Antriebe	Ruote di frizione (gomma su metallo) Friction wheel drive (rubber on metal) Kupplungsräder (Gummi auf Metall)	Cinghie trapezoidali V belt drives Keilriemen	Cinghie dentate Toothed belts Zahnriemen	Ingranaggi cilindrici Spur gears Zylinderzahnräder	Catene Chain drives Ketten

1.4 Verifiche

RX 700 Series

Verifiche

Caso A)

Per carichi radiali minori di $0.25 Fr_1'$ è necessario verificare soltanto che contemporaneamente al carico radiale sia presente un carico assiale non superiore a 0.2 volte Fr_1' ;

Caso B)

Per carichi radiali maggiori di $0.25 Fr_1'$

1) Calcolo abbreviato: Fr (input) $< Fr_1'$ e che contemporaneamente al carico radiale sia presente un carico assiale non superiore a 0.2 volte Fr_1' ;

2) Calcolo completo per il quale occorre fornire i seguenti dati:

- momento torcente applicato o potenza applicata
- n_1 (giri al minuto dell'albero veloce)
- carico radiale Fr (direzione, intensità, verso)
- senso di rotazione dell'albero
- grandezza e tipo del riduttore scelto
- tipo olio impiegato e sua viscosità
- esecuzione grafica assi:
- inoltre per la verifica del reggispinta occorre conoscere:
 - spinta assiale F_a statica e dinamica ricavabile dal diametro del nocciolo e dalla pressione di lavoro
 - dimensioni della flangia e del codolo vite

Consultare il supporto Tecnico per la verifica.

1.4 Verification

Verification

Caso A)

For overhung loads lower than $0.25 Fr_1'$, ensure that the thrust load applied simultaneously with OHL is not greater than 0.2 times Fr_1' ;

Caso B)

For overhung loads greater than $0.25 Fr_1'$
 1) Quick calculation method: Fr (input) $< Fr_1'$ and thrust load applied simultaneously with OHL not greater than 0.2 times Fr_1' ;

2) For the standard calculation method, the following information is required:

- applied torque or power
- n_1 (input shaft rpm)
- overhung load Fr (orientation, amount of loading, direction)
- direction of rotation of shaft
- size and type of selected gear unit
- oil type and viscosity
- shaft arrangement:
 - The following information is also necessary to check thrust bearing selection:
 - static and dynamic thrust force F_a calculated on the basis of core diameter and operating pressure
 - dimensions of screw flange and screw stub shaft.

Please contact Engineering for a verification.

1.4 Überprüfungen

Überprüfungen

Fall A)

Bei Radialkräften unter $0.25 Fr_1'$ muss nur überprüft werden, dass gleichzeitig mit der Belastung durch die Radialkraft auch eine Axialkraft von nicht mehr als 0.2 Mal Fr_1' vorliegt.

Fall B)

Bei Radialkräften über $0.25 Fr_1'$

1) Verkürzte Berechnungsgleichung: Fr (input) $< Fr_1'$ und dass gleichzeitig mit der Belastung durch die Radialkraft auch eine Axialkraft von nicht mehr als 0.2 Mal Fr_1' vorliegt.

2) Vollständige Berechnungsgleichung für die folgende Daten erforderlich sind:

- appliziertes Drehmoment oder applizierte Leistung
- n_1 (Drehungen/Minute der Antriebswelle)
- Radialkraft Fr (Richtung, Intensität, Seite)
- Drehrichtung der Welle
- Baugröße und Typ des gewählten Getriebes
- verwendeter Öltyp und dessen Viskositätsgrad
- grafische Achsenausführung
- Darüber hinaus muss man für die Überprüfung des Drucklagers folgende Daten verfügbar haben:
 - statische und dynamischer Axialschub F_a , der sich aus dem Durchmesser des Kerns und dem Arbeitsdruck ergibt
 - Maß des Flanschs und des Schnecken-schafts.

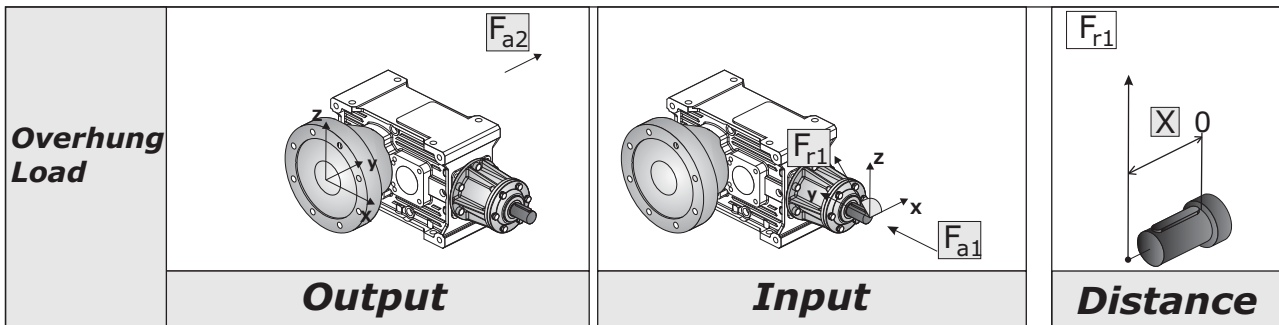
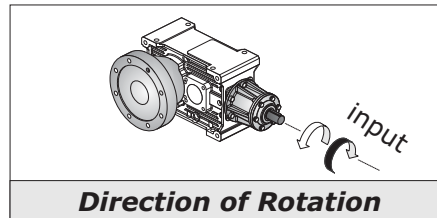
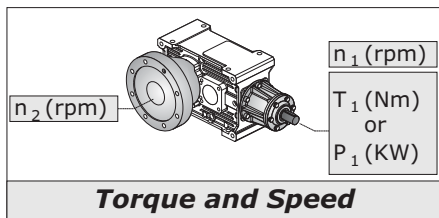

1.4 Verifiche

05 5)

Verifica carichi

RX 800 Series

Qualora il collegamento tra riduttore e macchina motrice sia effettuato con mezzi che generano carichi radiali sull'estremità d'albero veloce, occorre fare le seguenti verifiche.

carichi radiali sull'estremità d'albero veloce, occorre fare le seguenti verifiche.

Calcolo Fr_1'

I carichi massimi F_{r1} sono calcolati con $F_s=1$ ed a una distanza dalla battuta dell'albero di 0.5 S se albero veloce o 0.5 R se albero lento.

Per distanze variabili tra 0 e una distanza "X" bisogna utilizzare le tabelle seguenti.

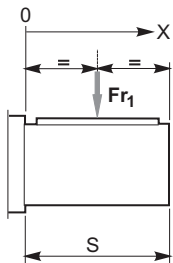

$$Fr_1' = Fr_1 \cdot \left(\frac{B}{B + X - \frac{S}{2}} \right)$$

B

Coefficienti correttivi del carico radiale di catalogo in entrata Fr_1 in funzione della distanza dalla battuta
 Load location factors to adjust input OHL capacity rating Fr_1 based on distance from shoulder
 Korrekturkoeffizient der Radialkraft am Antrieb Fr_1 gemäß Katalog in Abhängigkeit des Ansatzabstands

	Size	802	804	806	808	810	812	814	816	818	820
B	RX02	53	61	67	75	82	90	100	109	120	133

Calcolo Fr

Per calcolare il carico Fr agente sull'albero veloce o lento diamo formule approssimate per alcune trasmissioni più comuni, per la determinazione del carico radiale su albero veloce o lento.

1.4 Verification

5) Overhung and thrust load verification

When a gear unit is connected to prime mover or driven machine using overhung drive members that place a radial load on input or output shaft end, check the following loads.

Fr_1' calculation

Load capacity ratings F_{r1} consider a service factor $F_s=1$ and load location at a distance from shaft shoulder of 0.5 S for input shafts or 0.5 R for output shafts.

Where load is applied at a distance from shoulder between 0 and an "X" distance, refer to the following tables.

1.4 Überprüfungen

5) Überprüfung der Radial- und Axialkräfte

Erfolgt die Verbindung zwischen Getriebe und Kraft- oder Arbeitsmaschine mit Vorrichtungen, die Radialkräfte auf das Ende der Antriebswelle ausüben, sind folgende Überprüfungen erforderlich.

Berechnung von Fr_1'

Die maximalen Belastungskräfte F_{r1} werden mit $F_s=1$ und auf einem Abstand vom Wellenansatz von 0.5 S im Fall der Antriebswelle oder 0.5 im Fall der Abtriebswelle berechnet.

Bei zwischen 0 und einer Distanz "X" variierenden Abständen müssen folgende Tabellen verwendet werden.

X [mm]	Distanza dalla battuta dell'albero	Distance from shaft shoulder	Distanz vom Wellenansatz
Fr_1' [N]	Carico radiale ammissibile su albero entrata alla distanza X	Permissible input shaft OHL at distance X	Antriebswelle auf Distanz X zulässige Radialkraft
Fr_1 [N]	Carico radiale ammissibile su albero entrata indicato a catalogo	Input shaft OHL capacity as per catalogue rating	Antriebswelle gemäß Katalogangaben zulässige Radialkraft
S [mm]	Sporgenza dell'albero entrata	Input shaft projection	Überstand der Antriebswelle
B	Coefficiente da tabella	Load location factor from table	Koeffizient aus Tabelle

Fr calculation

Use the formula and the approximate factors for input or output overhung load determination referred to the most common drive members to calculate Fr load at output shaft.

Berechnung der Fr

Für die Berechnung der an der Abtriebswelle oder Antriebswelle wirkenden Belastungen Fr geben wir approximative Formeln an, die für einige der allgemeinen Antriebsformen zum Bestimmen der auf die An- oder Abtriebswelle einwirkenden Radialkraft verwendet werden kann.

$Fr = k \cdot \frac{T}{d}$	Fr [N] Carico radiale approssimato Approximate overhung load Approx. Wert - Radialkraft	d [mm] Diametro pulegge, ruote Pulley diameter, wheels Durchmesser Räder, Riemenscheiben	k Fattore di collegamento Connection factor Anschlusswert	T [Nm] Momento torcente Torque Drehmoment	
k =	7000	5000	3000	2120	2000
Trasmissioni Drive member Antriebe	Ruote di frizione (gomma su metallo) Friction wheel drive (rubber on metal) Kupplungsräder (Gummi auf Metall)	Cinghie trapezoidali V belt drives Keilriemen	Cinghie dentate Toothed belts Zahnriemen	Ingranaggi cilindrici Spur gears Zylinderzahnräder	Catene Chain drives Ketten

1.4 Verifiche

RX 800 Series

Verifiche

Caso A)
Per carichi radiali minori di $0.25 Fr_1'$ è necessario verificare soltanto che contemporaneamente al carico radiale sia presente un carico assiale non superiore a 0.2 volte Fr_1' ;

Caso B)
Per carichi radiali maggiori di $0.25 Fr_1'$
1) Calcolo abbreviato: Fr (input) $< Fr_1'$ e che contemporaneamente al carico radiale sia presente un carico assiale non superiore a 0.2 volte Fr_1' ;

2) Calcolo completo per il quale occorre fornire i seguenti dati:
- momento torcente applicato o potenza applicata
- n_1 (giri al minuto dell'albero veloce)
- carico radiale Fr (direzione, intensità, verso)
- senso di rotazione dell'albero
- grandezza e tipo del riduttore scelto
- tipo olio impiegato e sua viscosità
- esecuzione grafica assi:
- inoltre per la verifica del reggispinta occorre conoscere:
- spinta assiale F_a statica e dinamica ricavabile dal diametro del nocciolo e dalla pressione di lavoro
- dimensioni della flangia e del codolo vite

Consultare il supporto Tecnico per la verifica.

1.4 Verification

Verification

Case A)
For overhung loads lower than $0.25 Fr_1'$, ensure that the thrust load applied simultaneously with OHL is not greater than 0.2 times Fr_1' ;

Case B)
For overhung loads greater than $0.25 Fr_1'$
1) *Quick calculation method: Fr (input) $< Fr_1'$ and thrust load applied simultaneously with OHL not greater than 0.2 times Fr_1' ;*

2) *For the standard calculation method, the following information is required:*
- *applied torque or power*
- *n_1 (input shaft rpm)*
- *overhung load Fr (orientation, amount of loading, direction)*
- *direction of rotation of shaft*
- *size and type of selected gear unit*
- *oil type and viscosity*
- *shaft arrangement:*
- *The following information is also necessary to check thrust bearing selection:*
- *static and dynamic thrust force F_a calculated on the basis of core diameter and operating pressure*
- *dimensions of screw flange and screw stub shaft.*

Please contact Engineering for a verification.

1.4 Überprüfungen

Überprüfungen

Fall A)
Bei Radialkräften unter $0.25 Fr_1'$ muss nur überprüft werden, dass gleichzeitig mit der Belastung durch die Radialkraft auch eine Axialkraft von nicht mehr als 0.2 Mal Fr_1' vorliegt.

Fall B)
Bei Radialkräften über $0.25 Fr_1'$
1) Verkürzte Berechnungsgleichung: Fr (input) $< Fr_1'$ und dass gleichzeitig mit der Belastung durch die Radialkraft auch eine Axialkraft von nicht mehr als 0.2 Mal Fr_1' vorliegt.
2) Vollständige Berechnungsgleichung für die folgende Daten erforderlich sind:
- appliziertes Drehmoment oder applizierte Leistung
- n_1 (Drehungen/Minute der Antriebswelle)
- Radialkraft Fr (Richtung, Intensität, Seite)
- Drehrichtung der Welle
- Baugröße und Typ des gewählten Getriebes
- verwendeter Öltyp und dessen Viskositätsgrad
- grafische Achsenausführung
- Darüber hinaus muss man für die Überprüfung des Drucklagers folgende Daten verfügbar haben:
- statische und dynamischer Axialschub F_a , der sich aus dem Durchmesser des Kerns und dem Arbeitsdruck ergibt
- Maß des Flanschs und des Schnecken-schafts.

Für eine Überprüfung die Technischen Unterlagen konsultieren.

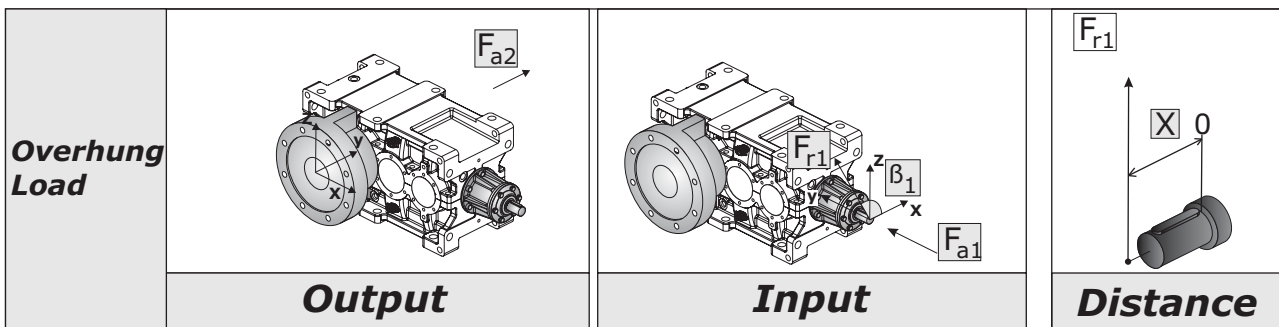
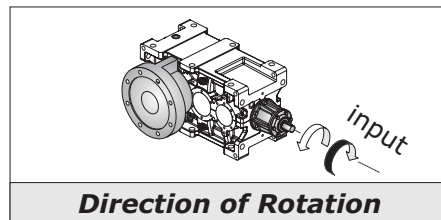
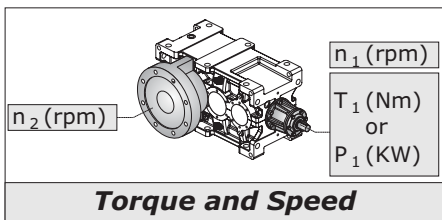

1.4 Verifiche

06 6) Verifica Posizione di montaggio

07 7) Adeguatezza della potenza termica del riduttore:

Nel caso di solo riduttore in servizio continuo o intermittente gravoso in ambienti a temperatura elevata e/o con difficoltà di scambio termico (es. acciaierie) è necessario verificare che la potenza termica nominale corretta dai fattori sia superiore alla potenza assorbita come evidenziato nella seguente equazione:

1.4 Verification

6) Check mounting position

7) Ensure gear unit thermal power is suitable for the application:

If a gear unit is to be used in continuous or intermittent duty in environments where high temperatures and/or poor heat exchange are encountered (such as steelworks), check to ensure the thermal power obtained after application of the relevant correction factors is greater than absorbed power, i.e. that the following condition is verified:

$$P_1 \leq P_{IN} \cdot fm \cdot fa \cdot fd \cdot fp \quad [kW]$$

Dove:

P_{IN} = potenza termica nominale
 fm = fattore correttivo per la posizione di montaggio
 fa = fattore correttivo dell'altitudine
 fd = fattore correttivo del tempo di lavoro
 fp = fattore correttivo della temperatura ambiente

Where:

P_{ta} = thermal power rating
 fm = mounting position factor
 fa = altitude factor
 fd = operation time factor
 fp = ambient temperature factor

1.4 Überprüfungen

6) Prüfen der Einbaulage

7) Angemessene thermische Grenzleistung des Getriebes:

Wird ein einziges Getriebe im Dauerbetrieb oder harten Schaltbetrieb in einer Umgebung mit hohen Temperaturen und/oder einem schwierigem Wärmeaustausch (z.B. Stahlwerke) eingesetzt, muss geprüft werden, dass die thermische, von den jeweiligen Faktoren korrigierte Nenngrenzleistung über der Aufnahmeleistung liegt, wie es in der folgenden Gleichung dargestellt wird:

Hier ist:

P_{ta} = thermische Nenngrenzleistung
 fm = Korrekturfaktor für Einbaulage
 fa = Höhenkorrekturwert
 fd = Korrekturfaktor der Arbeitszeit
 fp = Korrekturfaktor der Umgebungstemperatur

RX 700 - Qualora tale condizione non sia verificata occorre consultarci.

RX 700 - In case such operation condition is not verified please get in touch with us.

RX 700 - Wenn diese Bedingung nicht erfüllt wird, bitten wir Sie sich an uns zu wenden.

RX 800 - Qualora tale condizione non sia verificata occorre sostituire la ventola con un gruppo di raffreddamento con scambiatore di calore. Per selezionare il gruppo di raffreddamento adeguato occorre determinare la P_{ta} necessaria:

RX 800 - If this condition is not verified, opt for a heat exchanger instead of fan cooling. To select a suitable cooling unit, you need to determine required P_{ta} :

RX 800 - Sollte diese Bedingung nicht gegeben sein, muss der Lüfter durch ein Kühlaggregat mit Wärmeaustauscher ersetzt werden. Vor der Wahl des angemessenen Kühlaggregats muss zunächst die erforderliche P_{ta} bestimmt werden:

RX 700 Series
 $P_{ta} = 0$

$$P_{ta} \geq P_1 - (P_{IN} \cdot fm \cdot fa \cdot fd \cdot fp) \quad [kW]$$

dove:

P_{ta} = potenza termica addizionale

Where:

P_{ta} = additional thermal power required

Hier ist:

P_{ta} = thermische Zusatzgrenzleistung

Dopo avere selezionato il gruppo di raffreddamento, ripetere la verifica aggiungendo alla precedente il valore massimo di P_{tamax} del range identificato espresso in tabella, adeguato con i coefficienti correttivi di temperatura acqua e aria:

After selecting the cooling unit, check that the following condition is satisfied; as you can see, it considers the upper limit value P_{tamax} of the resulting tabulated range adjusted using the water and air temperature correction factors:

Nach erfolgter Wahl der Kühlgruppe, die Kontrolle wiederholen und dabei dem vorausgehenden Wert den max. Wert des P_{tamax} des in der Tabelle angegebenen Bereichs zurechnen und durch die Korrekturkoeffizienten der Wasser- und Lufttemperatur anpassen:

RX 700 Series
 $P_{tmax} = 0$

$$P_1 \leq (P_{IN} \cdot fm \cdot fa \cdot fd \cdot fp) + (P_{tamax} \cdot fw \cdot fc) \quad [kW]$$

dove:

P_{tamax} = potenza termica addizionale del range identificato espresso in tabella
 fw = coefficiente relativo alla temperatura dell'acqua (esclude fc)
 fc = coefficiente relativo alla temperatura dell'aria (esclude fw)

Where:

P_{tamax} = additional thermal power required obtained from resulting tabulated range
 fw = water temperature factor (excludes fc)
 fc = air temperature factor (excludes fw)

Hier ist:

P_{tamax} = thermische Zusatzgrenzleistung des identifizierten, in der Tabelle angegebenen Bereichs
 fw = Koeffizient bezüglich der Wassertemperatur (schließt fc aus)
 fc = Koeffizient bezüglich der Lufttemperatur (schließt fw aus)

1.4 Verifiche

1.4 Verification

1.4 Überprüfungen

P_{tN}

Potenza termica nominale
Thermal power rating
Termische Nenngrenzleistung

	RX 700 Series			RX 800 Series									
	712	716	720	802	804	806	808	810	812	814	816	818	820
RXO1	16.5	25	39	—									
RXO2	—	—	—	24	30	40	52	65	82	102	127	165	205

La P_{tN} è riferita ad un ambiente industriale aperto con velocità dell'aria di 1,4 m/s; nel caso di ambienti confinati scarsamente aerati consultarci

P_{tN} refers to an open space industrial environment with air speed 1,4 m/s; in the event of a confined space environment with poor ventilation, please contact the factory

Die P_{tN} bezieht sich immer auf einen Einsatz im industriellen offenen Umfeld mit Luftgeschwindigkeit 1,4 m/s; sollten Umgebungen mit geringer Belüftung daran angrenzen, bitten wir Sie, sich mit uns in Verbindung zu setzen

f_m

Fattore correttivo per la posizione di montaggio, velocità e rapporto
Correction factor accounting for mounting position, speed and ratio
Korrekturfaktor für Einbaulage, Drehzahl und Übersetzungsverhältnis

f_m	RX 700 Series
	1.0

f_m	ir	all	M1-M2	M3-M6						
				n_1						
				0-749	0- n_{1max}	750-1250	1251-1750	1751- n_{1max}	750-1250	1251-1750
RXO2 RXV2	802-806	19.4-124	1	1	1	1	1	1	1	1
	808-814	19.1-41.4			0.95	0.85	0.7	0.85	0.75	0.6
		43.6-123			1	0.9	0.75	0.9	0.8	0.65
	816-820	19.3-39.3			0.85	0.75	0.6	0.7	0.65	0.5
		44.1-124			0.9	0.8	0.65	0.75	0.7	0.55

N.B. I valori di n_{1max} sono riportati al punto 4

NOTE: n_{1max} values are listed at point 4

HINWEIS: Die Werte n_{1max} werden unter Punkt 4 angegeben.

$f_m = 1$ - nel caso in cui n_1 richieda la lubrificazione forzata

$f_m = 1$ - if n_1 required forced lubrication

$f_m = 1$ - / falls n_1 eine Zwangsschmierung erfordert

f_a

Fattore correttivo dell'altitudine
Altitude factor
Korrekturwert der Höhe

m	0	750	1500	2250	3000
f_a	1	0.95	0.90	0.85	0.81

f_d

Fattore correttivo del tempo di lavoro
Operation time factor
Korrekturwert der Betriebszeit

S3%	100	80	60	40	20
f_d	1	1.05	1.15	1.35	1.8

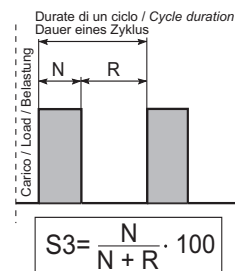

1.4 Verifiche

1.4 Verification

1.4 Überprüfungen

fp

Fattore correttivo della temperatura ambiente
Ambient temperature factor
 Korrekturfaktor der Umgebungstemperatur

Temperatura ambiente <i>Ambient temperature</i> Umgebungstemperatur	50 °C	40 °C	30 °C	20 °C	10 °C	0 °C
fp	0.63	0.75	0.87	1	1.12	1.25

Pta [kW]

Potenza termica addizionale
Additional thermal power
 Thermische Zusatzgrenzleistung

Raffreddamento con scambiatore acqua-olio (Tacqua=15°C)
Cooling by water-oil exchanger (Twater=15°C)
 Kühlung durch Wasser-/Ölaustauscher (TWasser=15°C)

RFA...		RXO-V 2
Size	Q _{min}	
1	6	≤ 46
2	6	47 ÷ 74
3	16	75 ÷ 139
4	30	140 ÷ 373
5	80	374 ÷ 666

Raffreddamento con scambiatore aria-olio (Taria=20°C)
Cooling by air-oil exchanger (Tair=20°C)
 Kühlung durch Luft-/Ölaustauscher (TLuft=20°C)

RFA...		RXO-V 2
Size	Q _{min}	
1	6	≤ 103
2	13	104 ÷ 138
3-A 3-B	32	139 ÷ 269
4	112	270 ÷ 451
5	112	452 ÷ 676
6	160	677 ÷ 849
7	160	850 ÷ 1334

fw

Coefficiente relativo alla temperatura dell'acqua
Water temperature factor
 Koeffizient bezüglich der Wassertemperatur

Twater	15°C	20° C	25° C	30° C
fw	1	0.85	0.7	0.6

fc

Coefficiente relativo alla temperatura dell'aria
Air temperature factor
 Koeffizient bezüglich der Lufttemperatur

Tair	15° C	20° C	25° C	30° C	35° C	40° C
fc	1.12	1	0.88	0.75	0.65	0.5

Una volta selezionato lo scambiatore è necessario verificare se la quantità di olio del riduttore è sufficiente a garantire un corretto funzionamento del gruppo. Pertanto deve essere verificata la relazione:

After selecting the cooling system it's necessary to check if the oil quantity is enough for making it work.

Therefore check the following formula:

Nach der Auswahl des Kühlsystems ist es nötig mit unten stehender Formel zu überprüfen, ob die Ölmenge für diese Arbeit ausreichend ist:

$$Q_{rid} \geq Q_{min} \times 1.2$$

Q_{rid} - Quantità olio di riempimento del riduttore (vedere 1.8)

Q_{rid} - Gearbox oil quantity (l) look at points 1.8

Q_{rid} - Ölfüllmenge des Getriebes siehe Punkt 1.8

Q_{min} - Quantità olio minima che deve avere il serbatoio olio per garantire il funzionamento del gruppo.

Q_{min} - Minimum tank oil quantity to assure the cooling running.

Q_{min} - Minimale Ölfüllung im Tank, um die Kühlung sicherzustellen.

Qualora la relazione non fosse soddisfatta è necessario prevedere un serbatoio aggiuntivo

If the formula is not satisfied, it will be necessary to add another oil tank.

Sollte die Relation nicht zufriedenstellend sein, muss ein Zusatztank vorgesehen werden.

1.4 Verifiche

09 9) Condizioni di impiego:
 9.1 - $t_a > 0\text{ }^\circ\text{C}$: vedere i punti 1.8;
 9.2 - $t_a < -10\text{ }^\circ\text{C}$: contattare il nostro servizio tecnico-commerciale.

10 10) Verifica peso motore elettrico:

RX 700 Series
 Qualora la grandezza del motore elettrico installato sia maggiore della IEC 180 (peso 165 Kg) e qualora la posizione di montaggio del riduttore sia tale da porre il motore nelle posizioni 1-2-3 è necessario contattare il nostro servizio tecnico per verificare se l'installazione è idonea, considerando il peso del motore installato e il fattore di servizio dell'applicazione.

P_{KG} - peso motore elettrico

11 11) Coppia frenatura-Motore Autofrenante

Nel caso di frenature T_{2max} può essere considerata come quella parte della coppia decelerante (T_{2dec}) che passa attraverso l'asse lento del riduttore:

1.4 Verification

9) *Using conditions:*
 9.1 - $t_a > 0\text{ }^\circ\text{C}$: look at points 1.8;
 9.2 - $t_a < -10\text{ }^\circ\text{C}$: contact our technical sales dept.

10) *Verify of the electric motor weight:*

If the input electric motor is bigger than IEC 180 (weight 165 Kg) and the mounting position is 1-2-3, it will be necessary to contact our technical sales department to check the electric motor weight and the service factor of the installation.

P_{KG} - Electric motor weight

11) *Braking torque - Brake motor*

For braking T_{2max} may be considered as that portion of deceleration torque (T_{2dec}) passing through the gear unit output (low speed) shaft:

1.4 Überprüfungen

9) Anwendungsbedingungen:
 9.1 - $t_a > 0\text{ }^\circ\text{C}$: siehe Punkt 1.8;
 9.2 - $t_a < -10\text{ }^\circ\text{C}$: bitte kontaktieren sie unsere technische Verkaufsabteilung.

10) Überprüfung des

Wenn der elektrische Antriebsmotor größer als IEC 180 (ca. 165 kg Gewicht) und in Position 1 bis 3 montiert ist, kontaktieren sie bitte unsere technische Verkaufsabteilung wegen Überprüfung von Gewicht und Servicefaktor.

P_{KG} - Gewicht E-Motor

11) Bremsmoment – Bremsmotor

Bei Bremsungen kann T_{2max} als der Teil des Beschleunigungsmoments Abbremsmoment (T_{2dec}), der durch die Abtriebsachse des Getriebes läuft, angesehen werden:



$$T_{2max} = T_{2dec} = \left(\left(\frac{T_{1f} \cdot i}{\eta} \right) - T_{2n} \right) \cdot \left(\frac{J}{J + \frac{J_0}{\eta}} \right) + T_{2n} \quad [\text{Nm}]$$

dove:
 J: momento d'inerzia della macchina e del riduttore ridotto all'asse motore (kgm^2)
 J_0 : momento d'inerzia delle masse rotanti sull'asse motore (kgm^2)
 T_{1f} : coppia frenante dinamica (Nm)

Where:
 J: machine and gear unit inertial load reflected to motor shaft (kgm^2)
 J_0 : inertial load of rotating parts at motor shaft (kgm^2)
 T_{1f} : dynamic braking torque (Nm)

Hier ist:
 J: An der Motorachse reduziertes Trägheitsmoment der Maschine und des Getriebes (kgm^2)
 J_0 : Trägheitsmoment der an der Motorachse drehenden Massen (kgm^2)
 T_{1f} : dynamisches Bremsmoment (Nm)

Prima della messa in servizio del riduttore è necessario verificare la seguente relazione:

Before using the gearbox, it's necessary to verify the following formula:

Vor Verwendung des Motors ist nach unten stehender Formel sicherzustellen:

$$T_{2max} < 2 \times T_N$$

Qualora la condizione non sia rispettata è necessario provvedere alla regolazione della coppia di frenatura.

If the condition is not respected, it will be necessary to adjust the braking torque.

Wenn diese Bedingung nicht erreicht wird, ist es notwendig das Bremsmoment entsprechend einzustellen.

1.5 Stato di fornitura

1.5.1 Verniciatura e protezione - RX 700

I riduttori sono verniciati esternamente con smalto a polvere termoidurente blu RAL 5010, salvo disposizioni contrattuali diverse

La protezione è idonea a resistere a normali ambienti industriali anche esterni, e a consentire finiture ulteriori con vernici sintetiche.

Per maggiori informazioni relative allo stato di fornitura vedere la tabella seguente

Caratteristiche della Vernice

Le caratteristiche della vernice utilizzata sono le seguenti: polvere termoidurente a base di resine poliesteri, modificate con resine epossidiche.

A richiesta è possibile fornire:

- 1-Ciclo di verniciatura;
- 2-Le caratteristiche di spessore, durezza, resistenza alla corrosione;
- 3-Scheda tecnica della Polvere utilizzata.

Nel caso si prevedano condizioni ambientali particolarmente aggressive occorre adottare prodotti adeguati apposti con opportuno ciclo di verniciatura. In questi casi si suggerisce di concordare il ciclo in fase di ordine. (TYP0-TYP1-TYP2-TYP3-TYP4).

1.5.2 Protezione alla corrosione e protezione superficiale - RX 800

General information

GSM propone diverse soluzioni protettive opzionali per motori e riduttori che lavorano in speciali condizioni ambientali.

Le misure protettive sono costituite da:

- Protezione corrosiva e protezione superficiale per motori e riduttori;
- Colore Standard RAL 5010

1.5.2.1 - Protezione Corrosiva

La protezione corrosiva è ottenuta con le seguenti specifiche come standard:

- Le targhette sono realizzate in acciaio inox;
- Applicazione di un prodotto anticorrosivo temporaneo per proteggere le superfici di accoppiamento delle flange e gli alberi uscita.

Nel caso di specifiche richieste è possibile applicare tutte le viti di fissaggio in acciaio inox.

1.5.2.2 - Verniciatura e protezione Superficiale

I riduttori preventivamente sabbiati vengono verniciati con vernice ad alto solido, internamente antiolio ed esternamente con fondo epossidico anticorrosivo di colore grigio o rosso ricoperto da finitura poliuretanica bicomponente di colore Blu RAL 5010 (TYP1).

La protezione ottenuta è idonea a resistere in ambienti mediamente corrosivi, industriali interni ed esterni e consente ulteriori finiture a scelta del cliente.

Nel caso si debbano prevedere impieghi in ambienti industriali più aggressivi o corrosivi o estremi o più genericamente di tipo marino, occorre adottare prodotti adeguati apposti con opportuno ciclo di verniciatura. In questi casi si suggerisce di concordare il ciclo in fase di ordine.

La GSM comunque propone già cicli di verniciatura speciali selezionati per ambienti di questo tipo (TYP2 - TYP3 - TYP4).

1.5 Scope of the supply

1.5.1 Painting and protection - RX 700

The gearboxes are painted on surface with powder thermosetting blue RAL 5010 top coating, if there are not different agreements.

The protection is suitable to stand normal industrial environments, also outdoors, and allows additional synthetic paint finishes.

For further details about the supply conditions, please refer to the following table

Paint features

The features of the paint used are the following: thermosetting powder-coating based on polyester resins, modified with epoxy resins.

On request, we can supply:

- 1-Painting cycle specs;
- 2-Specifications for thickness, hardness, resistance to corrosion;
- 3-Technical data sheet of the Powder coating used.

In case of particularly aggressive weather condition it is necessary to paint the gearboxes with a special painting cycle. We suggest you to specify your requests while ordering our products. (TYP0-TYP1-TYP2-TYP3-TYP4).

1.5.2 - Corrosion and surface protection - RX 800

General information

GSM offers different protective solutions for motors and gearboxes which work in special weather condition

The protective measures are:

- Corrosion and surface protection for motors and gearboxes;
- Standard color RAL 5010

1.5.2.1 - Corrosion protection

The corrosion protection is the result of the following standard procedures:

- The name plates are made of inox steel;
- An anticorrosive temporary product is applied on the mechanized surfaces of flanges and output shafts

In case of special requests it is possible to use inox steel screws

1.5.2.2 - Painting and surface protection

Gearboxes, after being sand blasted, are painted with a specific paint, which has a double function. On the internal side it works as an anti-oil, while on the external side it works as a grey or red anticorrosive epoxy primer covered by a blue RAL 5010 (TYP 1) bi-component polyurethane finishing paint.

The above mentioned protection is suitable for internal and external industrial environments with corrosive effects on the average. It also gives to the customer the possibility to chose other finishing effects.

In case of use in aggressive or corrosive industrial or sea environments, it is necessary to use special products with the required painting cycle. We suggest you to specify these particular terms with our company.

GSM offers already special painting cycles, which have been created for these kind of environments (TYP2 - TYP3 - TYP4).

1.5 Lieferzustand

1.15.1 Lackierung und schutz - RX 700

Die Getriebe sind außen mit wärmehärtenden blauen, RAL 5010, Lack lackiert, außer anderweitig lautende vertragliche Vereinbarungen.

Dieser Schutz ist für einen Einsatz in normalen industriellen, auch im Freien liegenden Umfeldern geeignet und erlaubt Überlackierungen mit Synthetiklack.

Weitere Informationen zum Lieferzustand können der folgenden Tabelle entnommen werden.

Eigenschaften der Lackierung

Der verwendete Lack weist folgende Eigenschaften auf: wärmehärtender Pulverlack auf Polyesterharzbasis mit Epoxidharzen modifiziert.

Auf Anfrage erhältlich:

- 1-Lackierungszyklus;
- 2-Stärke, Härte, Korrosionsfestigkeit;

3-Technisches Datenblatt des verwendeten Pulverlacks.

Bei besonders aggressiven Umweltbedingungen müssen hierfür geeignete Produkte mit den entsprechenden Lackierzyklen verwendet werden. In diesen Fällen wird vorgeschlagen, dass Sie den Zyklus in der Auftragsphase vereinbaren.(TYP0-TYP1-TYP2-TYP3-TYP4).

1.5.2 - Korrosionsschutz und Oberflächenschutz - RX 800

Allgemeine Information

GSM bietet optional verschiedene Schutzmöglichkeiten für Motoren und Getriebe an, die in besonderen Umweltbedingungen arbeiten

Die Schutzmaßnahmen bestehen aus:

- Korrosionsschutz und Oberflächenschutz für Motoren und Getriebe;
- Standardfarbe RAL 5010

1.5.2.1 - Korrosionsschutz

Der Korrosionsschutz ist bei den folgenden Spezifikationen standardmäßig:

- Die Typenschilder sind aus Edelstahl;
- Anwendung eines temporären Antikorrosionsproduktes als Oberflächenschutz für die Flansch und Abtriebswellenverbindungen

Im Falle spezifischer Anfragen können alle Befestigungsschrauben aus Edelstahl verwendet werden.

1.5.2.2 - Lackierung und Oberflächenschutz

Die vorbeugend sandgestrahlten Getriebe werden mit Farbe mit hohem Feststoffgehalt lackiert, innen gegen das Öl und außen gegen Korrosion mit Epoxid in grauer oder roter Farbe. Und werden abschließend mit Bikomponentenpolyurethan in der Farbe blau RAL 5010 (TYP 1) überzogen..

Der erreichte Schutz ist geeignet für Bereiche mit durchschnittlicher Korrosion, für den industriellen Innen- und Außeneinsatz geeignet und erlaubt eine zusätzliche Endbearbeitung gemäß Kundenwunsch.

Sollte der Einsatz in industriellen Bereichen erfolgen, die aggressiver oder korrosiver oder extremer oder allgemein den marinen Bereich betreffen, müssen hierfür geeignete Produkte mit den entsprechenden Lackierzyklen verwendet werden. In diesen Fällen wird vorgeschlagen zuzustimmen.

Die GSM schlägt hier jedoch bereits speziell ausgewählte Lackierzyklen für Bereiche dieser Art vor (TYP2 - TYP3 - TYP4).

1.5 Stato di fornitura

1.5 Scope of the supply

1.5 Lieferzustand

RX 800 Series

Protezione superficiale Surface protection	Numero di strati Permutation of layers	Spessore Coat thick nes	Adatto per Suitable for
TYP 1 "STANDARD"	1x Primer 1x Two-component top coat	Circa/Approx. 120 micron A Secco/Dry	1 - Impatto ambientale BASSO - (condizioni ambientali normali) Low enviroment impact (Normal ambient condition) 2 - Umidità relativa inferiore al 90% Relative humidity below 90 % 3 - Temperatura superficiale massima. 120 °C Surface temperature up to max. 120 °C 4 - Categoria di corrosività "C3-M" (DIN EN ISO 12,944-2) Corrosivity category "C3-M" (DIN EN ISO 12,944-2)
TYP 2 Standard Rinforzato Standard Reinforced	1x Primer 1x Two-pack Intermediate 1x Two-pack top coat	Circa/Approx. 160 micron A Secco/Dry	1 - Impatto ambientale MEDIO Medium environmental impact 2 - Umidità relativa massima 95 % Relative humidity max. 95 % 3-Temperatura superficiale massima 120 °C Surface temperature up to max. 120 °C 4 -Categoria di corrosività "C4-M" (DIN EN ISO 12,944-2) Corrosivity category "C4-M" (DIN EN ISO 12,944-2)
TYP 3 Industriale Industrial	1x Primer 2x Two-pack Intermediate 1x Two-pack top coat	Circa/Approx. 240 micron A Secco/Dry	1 - Impatto ambientale ALTO - Applicazione industriale High environmental impact - Industrial Application 2 - Umidità relativa massima 100 % Relative humidity max. 100 % 3-Temperatura superficiale massima 120 °C Surface temperature up to max. 120 °C 4 - Categoria di corrosività "C5I-M" (DIN EN ISO 12,944-2) Corrosivity category "C5I-M" (DIN EN ISO 12,944-2)
TYP 4 Marino Marine	1x Zinc Primer 2x Two-pack Intermediate 2x Two-pack top coat	Circa/Approx. 320 micron A Secco/Dry	1 - Alto impatto ambientale - Applicazione ambiente marino High environmental impact - Marine Application 2 - Umidità relativa massima 100 % Relative humidity max. 100 % 3-Temperatura superficiale massima 120 °C Surface temperature up to max. 120 °C 4 - Categoria di corrosività "C5M-M" (DIN EN ISO 12,944-2) Corrosivitycategory "C5M-M" (DIN EN ISO 12,944-2)

A richiesta é possibile fornire ciclo di verniciatura ,schede tecniche dei prodotti utilizzati e report di prova
If requested, we can supply you with painting procedures, data sheets of the products which have been used and testing reports
Auf Anfrage ist es möglich den Lackierzyklus, technische Leistungsblätter der benutzten Produkte und Testberichte zur Verfügung zu stellen

OPT2 - Opzioni - Verniciatura
Options - Painting and surface protection
Optionen - Lackierung und Oberflächenschutz

Serie Series Baureihe	Verniciatura Interna Inner painting Innenlackierung	Verniciatura Esterna Outer painting Außenlackierung	Piani lavorati Machined surfaces Bearbeitete Flächen	Alberi Shafts Wellen
		Tipo e Caratteristiche vernice Paint type and features Lacktyp und -eigenschaften	Verniciabile Can be painted Kann lackiert werden	
		TypSTM		
RX 700 Series	Uguale a verniciatura esterna Same as outer painting Wie Außenlackierung	Verniciatura a Polvere RAL 5010 Powder coating RAL 5010 Pulverlackierung RAL 501	Si Dopo Grassatura e Carteggiatura e applicazione di un PRIMER Yes After Degreasing and sanding and/or application of a PRIMER Ja Nach Fettentfernung und Abschiff und/oder Auftrag eines PRIMER	Quando il materiale è la ghisa sono protetti con prodotto antiruggine. When material is cast iron, they are protected with rustproof oil. Falls aus Gusseisen mit Rostschutzöl geschützt
		TYP 1		
RX 800 Series	fondo epossidico anticorrosivo di colore grigio o rosso Grey or red anticorrosive epoxy primer Epoxidkorrosionsschutz in grauer oder roter Farbe	ricoperto da finitura poliuretanica bicomponente di colore Blu RAL 5010 (TYP1) Covered by a blue RAL 5010 (TYP 1) bi-component polyurethane finishing paint überzogen mit Bikomponentenpolyrethan in der Farbe blau RAL 5010 (TYP 1)	Si	Protetti con prodotto antiruggine. Protected by oxide protectant Mit Rostschutzpaste geschützt.

ATTENZIONE
In caso di verniciatura o asportazione del prodotto antiruggine si chiede di porre attenzione alla preventiva protezione:
- Delle superfici lavorate, al fine di evitare che una eventuale verniciatura delle stesse pregiudichi il successivo accoppiamento.
-Delle tenute e più in generale di ogni parte plastica e di gomma, al fine di non variarne le caratteristiche chimico fisiche pregiudicandone così l'efficienza.
-Alla targa di identificazione per evitare la perdita di tracciabilità.
-Al tappo sfiato ed al tappo di livello olio, al fine di evitarne l'occlusione.

ATTENTION
If the product must be painted or cleaning off any antirust paint, protect the machined surfaces and oil seals/gaskets in order to prevent any damage. It is also necessary to protect the identification plate, the oil level plug (if fitted) and the hole in the breather plug (if fitted) against obstruction.

ACHTUNG
Sollten die Produkte lackiert werden oder Abbau des Rostschutzmittels, muss darauf geachtet werden, dass die bearbeiteten und Dichtflächen dabei geschützt werden, so dass verhindert werden kann, dass die Lackierung die chemisch-physischen Eigenschaften verändert und die Wirkung der Ölabdichtungen einschränkt. In der gleichen Weise und aus gleichem Grund müssen das Typenschild und die Öleinfüllschraube sowie die Bohrung der Entlüftungsschraube (wo vorhanden) geschützt werden.

1.5 Stato di fornitura

1.5 Scope of the supply

1.5 Lieferzustand

1.5.3 MATERIALI COSTRUTTIVI

1.5.3 MATERIAL

1.5.3 KOSTRUKTIONSMATERIAL

1.5.3.1 Casse - Flange - Coperchi

1.5.3.1 Housings - Flanges - Covers

1.5.3.1 Gehäuse - Flanschen – Deckel

Serie Series Baureihe	Per ulteriori informazioni vedere 1.6.5 For more details, please read 1.6.5 Sie können Weitere Informationen siehe 1.6.5
RX 700 RX 800	

1.5.3.2 Materiale degli anelli di tenuta

1.5.3.2 Materials of Seals

1.15.2.2 Dichtungsstoffe

Serie Series Baureihe	OPT Opzioni - Materiale degli anelli di tenuta Options - Materials of Seals Optionen - Dichtungsstoffe	
	(Tenute STANDARD Oil Seals Standard Ölabdichtungen Standard) Opzioni - Disponibile Options Available Optionen - verfügbar
RX 700 RX 800	Per ulteriori informazioni vedere SEZIONE U For more details, please read SECTION U Sie können Weitere Informationen siehe ABSCHNITT U	

1.5.4 Lubrificazione

1.5.4 Lubrication

1.5.4 Schmierung

RX 700	OPT1 - Opzioni - Stato fornitura olio Options - Scope of the supply - Options - OIL Optionen - Lieferzustand - Optionen - Öl	
		Sigla ordine Designation order Bezeichnung Bestellung
	712	OUTOIL
	716	
720		

RX 800	OPT1 - Opzioni - Stato fornitura olio Options - Scope of the supply - Options - OIL Optionen - Lieferzustand - Optionen - Öl	
		Sigla ordine Designation order Bezeichnung Bestellung
	all sizes	OUTOIL

1.5 Stato di fornitura

1.5 Scope of the supply

1.5 Lieferzustand

1.5.4 Lubrificazione

1.5.4 Lubrication

1.5.4 Schmierung

ATTENZIONE:

Lo stato di fornitura è messo in evidenza con una targhetta adesiva posta sul riduttore.

Verificare la corrispondenza tra stato di

CAUTION:

Gearbox state of supply is indicated on a nameplate applied on gearbox.

Ensure that nameplate data and state of supply correspond.

ACHTUNG:

Der entsprechende Lieferzustand wird auf einem Aufkleber am Getriebe angegeben. Überprüfen Sie die Übereinstimmung zwischen effektivem Lieferzustand und Auf-

OPT1 - Opzioni - Stato fornitura olio- Options - Scope of the supply - Options - OIL Optionen - Lieferzustand - Optionen - Öl				
Stato fornitura Scope of the supply Lieferzustand	Riduttore - Lubrificazione Gearbox - Lubrication Getriebe - Schmierung	Tipo Type Typ	NOTE Note Hinweis	Targhetta Nameplate Aufkleber
OUTOIL Riduttore Privo di Lubrificante <i>Gearbox with no lubricant</i> Getriebe ohne Schmiermittel	Si consiglia l'uso di oli a base sintetica. Vedere a tale proposito le indicazioni riportate paragrafo 1.8. The use of synthetic oil is recommended. see details in paragraph 1.8. Der Einsatz von synthetischem Öl wird empfohlen. Siehe diesbezüglich die Hinweise im Abschnitt 1.8.		Se richiedi completi di lubrificante, verranno forniti con olio standard - " INOIL_STD " If customer requests supply of gearbox with lubricant, we shall supply - " INOIL_STD " Falls diese Getriebe mit Schmiermittelfüllung angefordert werden - " INOIL_STD "	
INOIL_STD Riduttore Completo di Lubrificante Standard STM <i>Gearbox with lubricant STM standard</i> Getriebe mit Standard Schmiermittel STM	RX700 OMALA S4 WE 320 RX 800 AGIP BLASIA 220	OilGear_TYPE CLP PG Synthetic PG OilGear_TYPE CLP Mineral	—	
INOIL_Food Riduttore Completo di Lubrificante "ALIMENTARE" <i>Gearbox with lubricant "FOOD-TYPE"</i> Getriebe mit Schmiermittel "LEBENSMITTEL"	RX 700 - RX 800 CASSIDA GL 320	OilGear_TYPE CLP HCE Synthetic HCE NSF H1	—	
ASOIL Riduttore Completo di Lubrificante Speciale - a richiesta <i>Gearbox with Special lubricant - On request</i> Getriebe mit Sondern-Schmiermittel - Auf Anfrage	A richiesta On request Auf Anfrage	OilGear_TYPE CLP PG Synthetic PG OilGear_TYPE CLP HC Synthetic PAO OilGear_TYPE CLP Mineral OilGear_TYPE CLP HCE Synthetic HCE NSF H1 Grease	—	

Nota campo- ASOIL

Nella targhetta sono riportate le seguenti informazioni:

- Code_Plate;
- Sigla lubrificante;
- ISO VG;
- Type DIN;
- NSF;
- Altre prescrizioni.

Note range-ASOIL

The type plate contains the following information:

- Code_Plate
- Lubricant type
- ISO VG
- Type DIN
- NSF
- other details

Hinweis Bereich-ASOIL

Auf dem Typenschild finden Sie folgende Informationen:

- Code_Plate
- Schmiermitteltyp
- ISO VG
- Type DIN
- NSF
- andere Hinweise

1.5 Stato di fornitura**1.5.4 Lubrificazione****Riduttori forniti con il cuscinetto schermato**

Se ne consiglia il ringrassaggio indipendentemente dalle ore di esercizio effettuate, dopo almeno 2-3 anni.

Pertanto è stato predisposto un ingrassatore per provvedere all'opportuno ringrassaggio.

Le Caratteristiche tecniche generali del grasso utilizzato sono:

- Inspessente: base di Litio Complesso;
- NGLI: 2;
- Olio: HCE - con aditivazione EP di viscosità minima ISO VG 220;
- Additivi: l'olio presente nel grasso deve avere caratteristiche di aditivazione EP;

SPECIFICHE E APPROVAZIONI
DIN51502: **KP-HCE-2 P-40**

1.5 Scope of the supply**1.5.4 Lubrication****Worm gearboxes with a shielded bearing**

It is recommended to grease it at least every 2-3 years regardless of the operating hours.

To this end it is provided with a greaser.

Following are the general technical features of the lubrication grease:

- Thickener: Complex Lithium-based;
- NGLI: 2;
- Oil: HCE with EP additives with minimum viscosity as per ISO VG 220;
- Additives: the oil in the grease must feature EP additive;

SPECIFICATIONS AND APPROVALS
DIN51502: **KP-HCE-2 P-40**

1.5 Lieferzustand**1.5.4 Schmierung****Getrieben mit abgeschirmtem Lager geliefert werden**

Wir empfehlen, unabhängig von den erfolgten Betriebsstunden, mindestens alle 2-3 Jahre ein entsprechendes Nachschmieren.

Daher wurde ein angemessener Schmiernippel für das Nachschmieren vorgesehen.

Allgemeine technische Eigenschaften des verwendeten Fetts:

- Verdickungsmittel: auf Lithiumkomplex;
- NGLI: 2;
- Öl: HCE mit Zusatz von EP mit Mindestviskosität gemäß ISO VG 220;
- Additive: das im Fett enthaltene Öl muss die Eigenschaften der EP Aditivierung aufweisen;

SPEZIFIKATIONEN
DIN51502: **KP-HCE-2 P-40**

1.6 Normative applicate**1.6.1 Specifiche prodotti non "ATEX"**

I riduttori della GSM SpA sono organi meccanici destinati all'uso industriale e all'incorporazione in apparecchiature meccaniche più complesse. Dunque non vanno considerati macchine indipendenti per una predeterminata applicazione ai sensi 2006/42/CE, né tantomeno dispositivi di sicurezza.

1.6 Standards applied**1.6.1 Specifications of non - "ATEX"****products**

GSM SpA gearboxes are mechanical devices for industrial use and incorporation in more complex machines. Consequently, they should not be considered neither self-standing machines for a pre-determined application according to 2006/42/EEC nor safety devices.

1.6 Angewendete Normen**1.6.1 Spezifikationen für produkte, die**

nicht der "ATEX"-norm entsprechen
Bei den Getrieben der GSM SpA handelt es sich um Mechanikorgane, die für den industriellen Einsatz und einen Einbau in komplexere Einrichtungen bestimmt sind. Sie werden deshalb weder unter dem Aspekt unabhängiger, für eine bestimmte Anwendung vorgesehener Maschinen im Sinne der 2006/42/EWG, noch als Sicherheitsvorrichtungen berücksichtigt.

1.6 Normative applicate

1.6.2 Specifiche prodotti "ATEX"

Campo applicabilità

La direttiva ATEX (94/9/CE) si applica a prodotti elettrici e non elettrici destinati a essere introdotti e svolgere la loro funzione in atmosfera potenzialmente esplosiva. Le atmosfere potenzialmente esplosive vengono suddivise in gruppi e zone a seconda della probabilità di formazione. I prodotti GSM sono Conformi alla seguente classificazione:

- 1- Gruppo: II
2- Categoria: **Gas 2G** polveri **2D**
3- Zona: Gas **1 ; 2** – Polveri **21;22**

1.6 Standards applied

1.6.2 Specifications of "ATEX" products

Application field

ATEX set of provisions (94/9/CE) is referred to electric and non-electric products which are used and run in a potentially explosive environment. The potentially explosive environments are divided into different groups and zones according to the probability of their formation. GSM products are in conformity with following classification:

- 1- Group : II
2- Type : **Gas 2G dust 2D**
3-Zone : Gas **1;2** – Dust **21;22**

1.6 Angewendete Normen

1.6.2 Spezifikationen für "ATEX"-produkte

Anwendungsbereich

Die ATEX-Richtlinie (94/9/EG) wird bei elektrischen und nicht elektrischen Produkten angewendet, die dazu bestimmt sind, in potentiell explosionsfähigen Atmosphären eingesetzt und betrieben zu werden. Die potentiell explosionsfähigen Atmosphären werden in Abhängigkeit der Wahrscheinlichkeit in Gruppen und Zonen unterteilt. Die GSM-Produkte entsprechen der folgenden Klassifizierung:

- 1- Gruppe: II
2- Kategorie: **Gas 2G** Staub **2D**
3- Zone: Gas **1;2** - Staub **21;22**

Massime temperature di superficiali / Max surface temperature allowed / Maximale Oberflächentemperaturen					
Classe di temperatura / Temperature class / Temperaturklasse	T1	T2	T3	T4	T5(1)
Massima temp.di superficie / Max surface temperature / Max. Oberflächentemperaturen (°C)	450	300	200	135	100(1)
Classi di temperatura ATEX dei prodotti GSM / ATEX temperature class of GSM products / ATEX Temperaturklassen der GSM-Produkte					

I prodotti GSM sono marcati classe di temperatura **T4** per IIG (atmosfera gassosa) e **135° C** per IID (atmosfera polverosa).

Nota 4:

Nel caso di Classe di temperatura **T5** occorre verificare la potenza limite termico declassata;

In tutti gli altri casi vale la potenza riportata a catalogo prevista per i singoli rapporti con fattore di servizio complessivo dell'applicazione pari a 1 e le considerazioni sul limite termico.

I prodotti del gruppo IID (atmosfera polverosa) vengono definiti dalla massima temperatura di superficie effettiva.

La massima temperatura di superficie è determinata in normali condizioni di installazione e ambientali (-20°C e +40°C) e senza depositi di polvere sugli apparecchi.

Qualunque scostamento da queste condizioni di riferimento può influenzare notevolmente lo smaltimento del calore e quindi la temperatura.

1.6.3. COME SI APPLICA

Al momento di una richiesta di offerta per prodotto conforme a normativa ATEX 94/9/CE occorre compilare la **scheda acquisizione dati** (www.stmspa.com).

Effettuare le verifiche come prima descritto.

I riduttori certificati verranno consegnati con:
-una seconda targhetta contenente i dati ATEX;
-ove previsto un tappo sfiato, tappo sfiato con molla interna;

-se rispondente alla classe di temperatura T4 e T5 verrà allegato un indicatore di temperatura (132 °C nel caso di T4 e 99°C rispettivamente per la T5)

-Indicatore di temperatura : termometro a singolo rilevamento, una volta raggiunta la temperatura indicata si annerisce segnalando il raggiungimento di tale limite.

GSM products are branded temperature class **T4** for IIG (gas environment) and **135°C** for IID (dust environment).

Note 4:

In case of **T5** Class of temperature the extreme down-graded thermic power should be checked.

In all the other instances, the power indicated on the catalogue for the single ratios with overall application service factor equal to 1 and the considerations on temperature limits apply.

The products of the family IID (dust environment) are defined by the max effective surface temperature.

Max surface temperature is determined in standard installation and environmental conditions (-20°C and +40°C) and in absence of dust on product surface.

Any other condition will modify the heat dissipation and consequently the temperature.

1.6.3. HOW IS IT APPLIED

In case of request of offer relating to any product in conformity with the provisions ATEX/94/9/CE, the **specifications paper** should be filled in (www.stmspa.com).

Perform the inspections as described above. Certified reducers will be delivered with:

- a second nameplate containing ATEX data;
- a breather valve with internal spring, where a breather is needed;
- if in accordance with classes of temperature T4 and T5, a temperature gauge will be included (132 °C in case of T4 and 99 °C in case of T5).
- Temperature gauge: single-reading thermometer, it blackens once temperature is reached, pointing out the achievement of that limit.

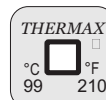
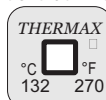

Die GSM-Produkte sind mit der Temperaturklasse **T4** für IIG (Atmosphäre mit gasförmiger Belastung) und **135° C** für IID (Atmosphäre mit staubförmiger Belastung) gekennzeichnet.

Hinweis 4:

Bei der Temperaturklasse **T5** muss die zurückgestufte thermische Grenzleistung überprüft werden. In den anderen Fällen gilt die im Katalog für die einzelnen Übersetzungsverhältnisse angegebene Leistung mit Betriebsfaktor einschließlich Applikation entsprechend 1 und die Berücksichtigungen im Hinblick auf die thermische Grenzleistung.

Die der Gruppe IID (Atmosphäre mit staubförmiger Belastung) angehörigen Produkte werden ihrer effektiven maximalen Oberflächentemperatur gemäß definiert.

Die maximale Oberflächentemperatur wird in normalen Einbau- und Umgebungsbedingungen (-20°C und +40°C) und ohne auf den Vorrichtungen vorhandenen Staubablagerungen bestimmt.

Jegliche Abweichung von diesen Bezugsbedingungen kann sich erheblich auf die Wärmeableitung bzw. auf die Betriebstemperatur auswirken.

1.6.2. ANWENDUNGSWEISE

Bei einer Angebotsanfrage für der Richtlinie ATEX 94/9/EG entsprechende Produkte muss das Datenerfassungsformular (www.stmspa.com) ausgefüllt werden.

Dazu die zuvor beschriebenen Kontrollen vornehmen. Die zertifizierten Getriebe werden wie folgt ausgestattet geliefert:

- mit einem zweiten Typenschild mit ATEX- Daten;
- wo vorgesehen, mit einem Entlüftungs- verschluss, Entlüftungsverschluss mit interner Feder;
- falls der Temperaturklasse T4 und T5 entsprechend, wird eine Temperaturanzeige vorgesehen (132 °C bei T4 und 99°C bei T5)
- Temperaturanzeige: einzelnes Erfassungsthermometer - bei Erreichen der angegebenen Temperatur wechselt die Farbe zur Anzeige der erreichten Temperatur in Schwarz.

1.6 Normative applicate**1.6.4 Direttive CE- marcatura CE- ISO9001****Direttiva Bassa Tensione 2006/95/CE**

I motoriduttori, motorinvii angolari, motorvariatori e i motori elettrici GSM sono conformi alle prescrizioni della direttiva Bassa Tensione .

2004/108/CE Compatibilità elettromagnetica

I motoriduttori, motorviiangolari, motorvariatori e i motori elettrici GSM sono conformi alle specifiche della direttiva di Compatibilità Elettromagnetica.

Direttiva Macchine 2006/42/CE

I motoriduttori, motorviiangolari, motorvariatori e i motori elettrici GSM non sono macchine ma organi da installare o assemblare nelle macchine.

Marchio CE, dichiarazione del fabbricante e dichiarazione di conformità.

I motoriduttori, motorvariatori e i motori elettrici hanno il marchio CE.

Questo marchio indica la loro conformità alla direttiva Bassa Tensione e alla direttiva Compatibilità Elettromagnetica.

Su richiesta, GSM può fornire la dichiarazione di conformità dei prodotti e la dichiarazione del fabbricante secondo la direttiva macchine.

ISO 9001

I prodotti GSM sono realizzati all'interno di un sistema di qualità conforme allo standard ISO 9001. A tal fine su richiesta è possibile rilasciare copia del certificato.

1.6.5 Normative riferimento Progettazione e Fabbricazione**Ingranaggi**

Gli ingranaggi cilindrici a dentatura elicoidale, sono rettificati sul profilo ad evolvente dopo cementazione, tempra e rinvenimento finale.

Gli ingranaggi conici a dentatura Gleason sono rodati, (o rettificati a seconda della grandezza del riduttore), dopo cementazione tempra e rinvenimento finale.

Cuscinetti

Tutti i cuscinetti sono del tipo a rulli conici o a rulli orientabili, di elevata qualità e dimensionati per garantire una lunga durata se lubrificati con il tipo di lubrificante previsto a catalogo.

Cuscinetti reggispinta di marca primaria della serie 294. E

Carcassa

La carcassa è ottenuta per fusione in GJL 250 UNI EN 1561 o in ghisa a grafite sferoidale UNI EN 1563 2004.

1.6 Standards applied**1.6.4 EC Directives-CE mark-ISO 9001****Directive 2006/95 EEC Low VoltageGSM**

geared motors, right angle drives with motor, motorvariators and electric motors meet the specification of the low voltage directive.

2004/108/EEC Electromagnetic Compatibility

GSM geared motors, right angle drives with motor, motorvariators and electric motors correspond to the specifications of the EMC directive.

Machinery Directive 2006/42/EC

GSM geared motors, right angle drives with motor, motorvariators and electric motors are not standalone machines, they are exclusively for installation into a machine or for assembly on a machine.

CE Mark, Conformity Declarations and Manufacturer's Declaration.

GSM geared motors, right angle drives with motor, motorvariators and electric motors carry the CE Mark.

It indicates conformity to the low voltage directive and to electromagnetic compatibility directive.

On request GSM supplies both the conformity declarations and the manufacturer's declaration according to the machine directive.

ISO 9001

GSM products have been designed and manufactured according to ISO 9001 quality system standard.

On request a copy of the certification can be issued.

1.6.5 Standards applied**Gearing**

Helical gear sets are first case hardened, hardened and tempered and finally their involute profile is ground.

Gleason bevel gear sets are first case hardened, hardened and tempered and finally broken in (or ground, depending on gear unit size).

Bearings

All bearings are high quality taper or self-aligning roller bearings suitably sized to ensure long service life provided the approved lubricants indicated in this catalogue are used.

Top brand thrust bearings series 294.E

Casing

Casings up to size 824-826 are cast from GJL 250 UNI EN 1561 cast iron or from Spheroidal cast iron.

1.6 Angewendete Normen**1.6.4 EG-Richtlinien - CE-Zeichen - ISO9001****Niederspannungsrichtlinie. 2006/95/EG**

Die Getriebemotoren, Winkelgetriebe, Verstellgetriebe und Elektromotoren der GSM entsprechen den Vorschriften der Niederspannungsrichtlinie.

2004/108/EG**Elektromagnetische****Verträglichkeit**

Die Getriebemotoren, Winkelgetriebe, Verstellgetriebe und Elektromotoren der GSM entsprechen den Vorschriften der Richtlinie zur Elektromagnetischen Verträglichkeit.

Maschinenrichtlinie 2006/42/EG

Die Getriebemotoren, Winkelgetriebe, Verstellgetriebe und Elektromotoren der GSM sind keine Maschinen sondern Organe, die in Maschinen eingebaut oder an diesen montiert werden.

CE-Zeichen, Hersteller- und Konformitätserklärung

Die Getriebemotoren, Verstellgetriebe und Elektromotoren tragen das CE-Zeichen.

Dieses Zeichen weist auf ihre Konformität mit der Niederspannungsrichtlinie und der Richtlinie zur Elektromagnetischen Verträglichkeit hin.

Auf Anfrage kann die GSM die Konformitätserklärung und die Herstellererklärung gemäß Maschinenrichtlinie zu den Produkten liefern.

ISO 9001

Die GSM-Produkte werden in einem Qualitätssystem gemäß dem Standard ISO 9001 realisiert. Auf Anfrage kann daher eine Kopie der Zertifizierung geliefert werden.

1.6.5 Bezugsnormen Entwicklung und Produktion**Zahnräder**

Das Evolventenprofil der Stirnrädergetriebe mit Schrägverzahnung wird nach dem Einsatzhärten, dem Abschrecken und dem Anlassen entsprechend geschliffen.

Die Kegelzahnräder mit Gleason-Verzahnung sind bereits eingelaufen (oder in Abhängigkeit der Getriebegröße geschliffen), dies erfolgt nach dem Einsatzhärten, Abschrecken und Anlassen.

Lager

Bei allen Lagern handelt es sich um hochqualitative Kegelrollenlager mit orientierungsfähigen Rollen und in Maßen, die so ausgelegt sind, dass sie bei Einsatz der gemäß Katalogangaben vorgesehenen Schmiermittel eine lange Lebensdauer garantieren.

Drucklager erster Qualität der Serie 294. E

Gehäuse

Die Gehäuse der Getriebe bis Baugröße 824-826 werden im Gussverfahren aus GJL 250 UNI EN 1561 oder Sphäroguss UNI EN 1563 2004 gewonnen.

1.6 Normative applicate**Alberi**

RX 700 - Gli alberi lenti sono verificati a flesso-torsione con elevato coefficiente di sicurezza.

Linguette secondo UNI 6604-69, DIN 6885 BI.

RX 800 - Gli alberi lenti sono verificati a flesso-torsione con elevato coefficiente di sicurezza. Le estremità d'albero cilindriche sono secondo UNI 6397-68, DIN 748, NF E 22.051, BS 4506-70, ISO/R 775-69, escluso corrispondenza R-S, con foro filettato in testa secondo DIN 1414. Linguette secondo UNI 6604-69, DIN 6885 BI, 1-68, NF E 27.656 22.175, BS 4235.1-72, ISO/R 773-69 escluso corrispondenza I.

Tutti i prodotti della GSM sono progettati nel rispetto delle seguenti normative:

Calcolo degli ingranaggi e cuscinetti

ISO 6336 - ISO10400 - DIN3991

La capacità di carico è stata calcolata a pressione superficiale e a rottura secondo la normativa ISO 6336 - ISO10400 - DIN3991 (a richiesta sono possibili verifiche secondo le norme AGMA 2001-C95 e AGMA 2003).

BS 721

Calcolo della capacità di carico delle viti e delle corone elicoidali.

ISO 281

Calcolo della durata a fatica dei cuscinetti volventi.

Alberi

DIN 743

Calcolo della durata a fatica degli alberi

Materiali

EN 10084

Acciaio da cementazione per ingranaggi e viti senza fine.

EN 10083

Acciaio da bonifica per alberi.

EN UNI 10025

Acciaio - Casse

UNI EN 1982 - UNI 5274

Bronzo per corone elicoidali.

UNI EN 1706

Alluminio e leghe di Alluminio

UNI EN 1561

Fusioni in ghisa grigia.

UNI EN 1563 2004

Getti di ghisa a grafite sferoidale

UNI 3097

Acciaio per cuscinetti per piste rotolamento.

1.6 Standards applied**Shafts**

RX 700 - Output shafts are calculations incorporate a high safety factor and are validated by bending and torsional stress analyses.

Keys are in accordance with UNI 6604-69, DIN 6885 BI.

RX 800 - Output shafts are calculations incorporate a high safety factor and are validated by bending and torsional stress analyses. Cylindrical shaft ends are in accordance with UNI 6397-68, DIN 748, NF E 22.051, BS 4506-70, ISO/R 775-69, excluding section R-S, with centre tapped hole at shaft end to DIN 1414. Keys are in accordance with UNI 6604-69, DIN 6885 BI, 1-68, NF E 27.656 22.175, BS 4235.1-72, ISO/R 773-69 excluding section I.

All GSM products are designed following these standards:

Calculation of gearboxes and bearings

ISO 6336 - ISO10400 - DIN3991

The load capacity of gear sets is calculated at contact and root bending stress in accordance with standard ISO 6336 - ISO10400 - DIN3991

(gears can be rated to AGMA 2001-C95 and AGMA 2003 on request).

BS 721:

Calculation of load capacity for worm gearing.

ISO 281:

Rolling bearings — Dynamic load ratings and rating life

Shafts

DIN743

Shafts — Dynamic load ratings and rating life

Materials

EN 10084

Case hardening steels for gears and worms

EN 10083

Quenched and Tempered Steels for shafts

EN UNI 10025

Steel - Casing

UNI EN 1982 - UNI 5274

Copper for helical worm-gears

UNI EN 1706

Aluminium alloy

UNI EN 1561

Grey iron casting

UNI EN 1563 2004

Spheroidal cast iron

UNI 3097

Ball and roller bearing steel

1.6 Angewendete Normen**Wellen**

RX 700 - Die Abtriebswellen werden unter Berücksichtigung eines hohen Sicherheitskoeffizienten auf Biegung-Windung getestet.

Die Federkeile entsprechen UNI 6604-69, DIN 6885 BI.

RX 800 - Die Abtriebswellen werden unter Berücksichtigung eines hohen Sicherheitskoeffizienten auf Biegung-Windung getestet.

Die Enden der zylindrischen Wellen entsprechen den Normen UNI 6397-68, DIN 748, NF E 22.051, BS 4506-70, ISO/R 775-69, ausgenommen Zuordnung R-S, mit Gewindebohrung in der Wellenspitze DIN 1414. Die Federkeile entsprechen UNI 6604-69, DIN 6885 BI, 1-68, NF E 27.656 22.175, BS 4235.1-72, ISO/R 773-69, ausgenommen Zuordnung I.

Alle Produkte der GSM werden unter Einhaltung folgender Normen entwickelt:

Berechnung der Zahnräder und Lager

ISO 6336 - ISO10400 - DIN3991

Die Belastbarkeit wurde auf Oberflächendruck und Bruch der Richtlinie ISO 6336 - ISO10400 - DIN3991 - gemäß berechnet (auf Anfrage können Überprüfungen den Normen AGMA 2001-C95 und AGMA 2003 gemäß vorgenommen werden).

BS 721

Berechnung der Belastungsfähigkeit der Schnecken und Schrägzahnräder.

ISO 281

Berechnung der Belastungsdauer der Wälzlager.

Wellen

DIN743

Berechnung der Belastungsdauer der Wellen.

Material

EN 10084

Einsatzstahl für Zahnräder und Schnecken.

EN 10083

Vergütungsstahl für Wellen.

EN UNI 10025

Stahl - Gehäuse

UNI EN 1982 - UNI 5274

Bronze für Schrägzahnräder

UNI EN 1706

Aluminium und Aluminiumlegierungen

UNI EN 1561

Grauguss-Legierungen

UNI EN 1563 2004

Sphäroguss

UNI 3097

Stahl für Lagergleitbahnen



RXO-V 700 - Series

CODE: Example of Order → RX O 1 704 C1 9.5	Maschine	Centerline Orientation	N° of reductions	Size	Shaft arrangement	Reduction ratio
	00-M	01-CO	02-NOR	03-SIZE	04-SA	05-IR

		712 716 720	

					A B AS BS

700 Series

RXO-V 700 - Series

PAM	63	G	EST	M1	-	-
Input Version	Input Shaft	IEC type and Input Shaft	Output Shaft	Mounting positions	Options	Position Terminal Box
06-IV	07-IS	08-IECT	10-OS	11-MP	12 OPT	13 PMT

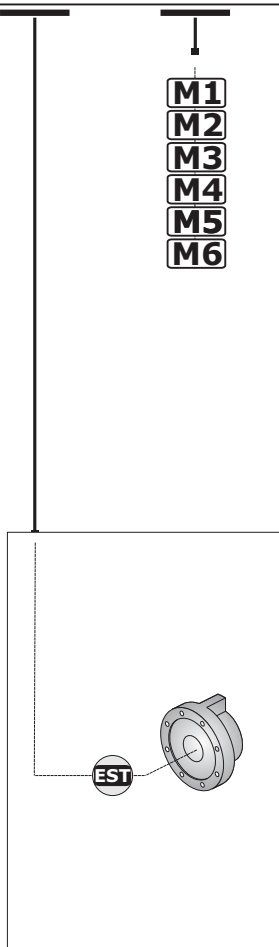
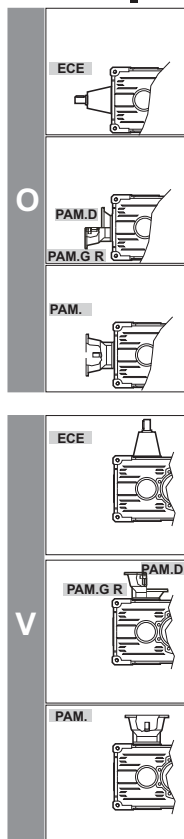

- M1
- M2
- M3
- M4
- M5
- M6

- VT
- VT1
- VT2
- U

- 1
- 2
- 3
- 4



RXO 800 - Series

CODE: Example of Order	RX	O	2	802	C1	24.9
WEB: Reference Designation	Maschine 00-M	Centerline Orientation 01-CO	N° of reductions 02-NOR	Size 03-SIZE	Shaft arrangement 04-SA	Reduction ratio 05-IR

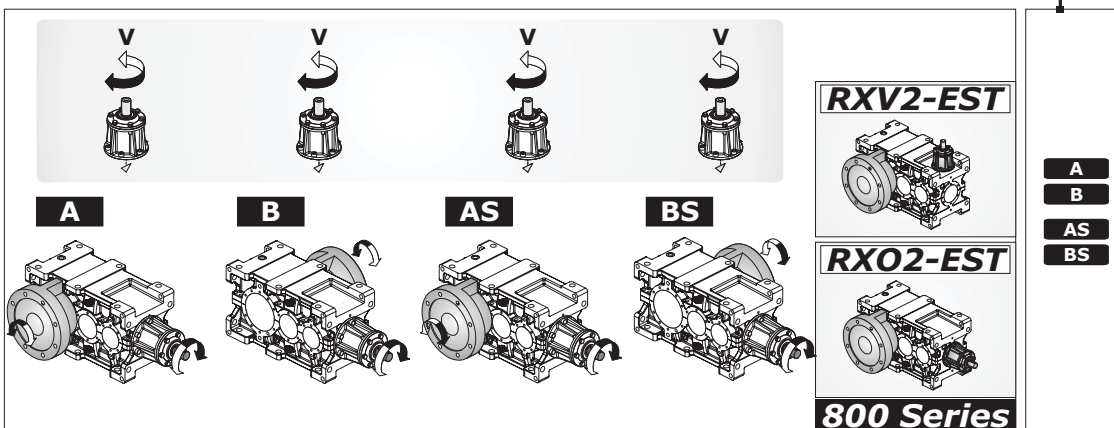
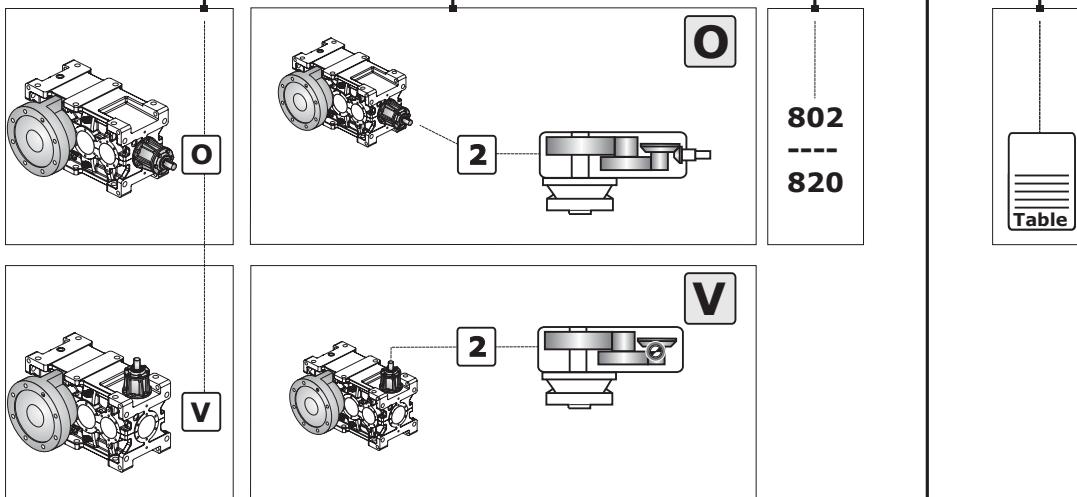

RXO 800 - Series

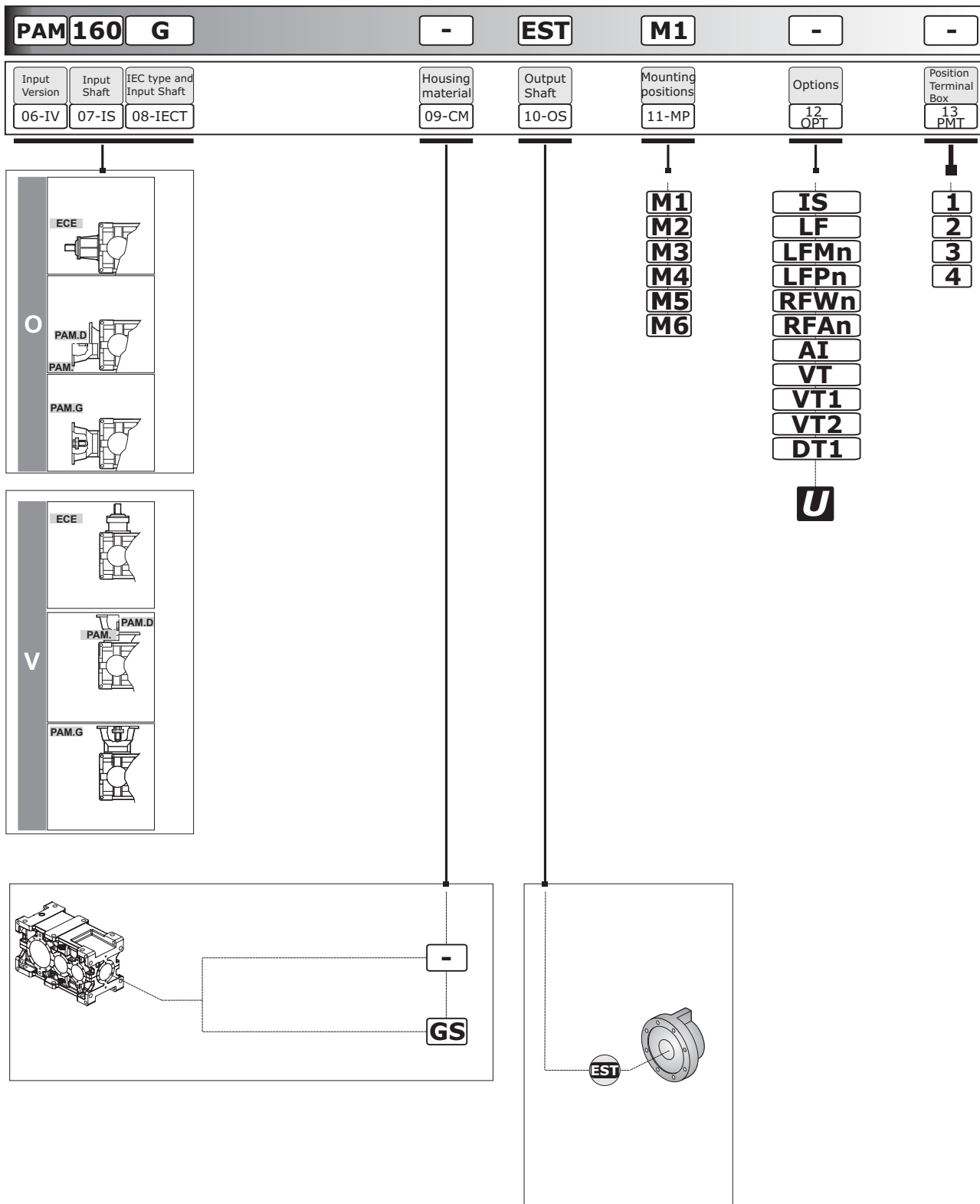

1.7 Designazione

1.7 Designation

1.7 Bezeichnung

00 M - Macchina

M - Maschine

M - Getriebe

RX

01 CO - Posizione Assi

CO - Centerline Orientation

CO - Bauform getriebestufen

RX 700 Series

RX 800 Series

O

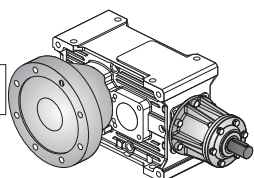

O

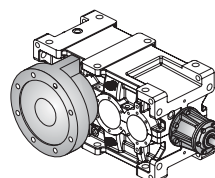

V

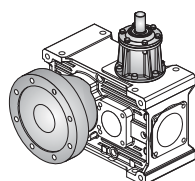

V

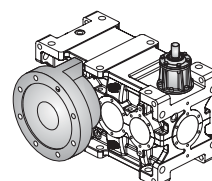

02 NOR - N° Stadi

NOR - N° of reductions

NOR - N° Anzahl der stufen

	RXO-RXV	RXO-RXV
RX 700	1	—
RX 800	—	2

03 SIZE - Grandezza

SIZE - Size

SIZE - Größe

	RX 700 Series			RX 800 Series									
	712	716	720	802	804	806	808	810	812	814	816	818	820
RXO1													
RXV1													
RXO2													
RXV2													

04 SA - Esecuzione grafica

SA - Shaft arrangement

SA - Grafische Ausführung

05 - SA	
A	B
AS	BS

05 IR - Rapporto di riduzione

IR - Reduction ratio

IR - Übersetzungsverhältnis

(Vedi prestazioni). Tutti i valori dei rapporti sono approssimati. Per applicazioni dove necessita il valore esatto consultare il ns. servizio tecnico.

(See ratings). Ratios are approximate values. If you need exact values for a specific application, please contact our Engineering.

(Siehe "Leistungen"). Bei allen Werten der Übersetzungen handelt es sich um approximative Wertangaben. Bei Applikationen, bei denen die exakte Wertangabe erforderlich ist, muss unser Technischer Kundendienst konsultiert werden.

1.7 Designazione

1.7 Designation

1.7 Bezeichnung

04 SA - Esecuzione grafica

SA - Shaft arrangement

SA - Grafische Ausführung

RX 700 - Series

A **B** **AS** **BS**

RXV1-EST
RXO1-EST

700 Series

EST

RX 800 - Series

A **B** **AS** **BS**

RXV2-EST
RXO2-EST

800 Series

EST

1.7 Designazione

1.7 Designation

1.7 Bezeichnung

RX 700 Series	06 IV Versione Entrata Input Version Antriebausführung	07 IS Albero Entrata Input Shaft Antriebswelle	08 IECT Tipo IEC e Albero Entrata IEC type and Input Shaft IEC Typ und Antriebswelle
ECE	ECE	—	—
PAM..	PAM	80	—
PAM..G		90	G
PAM..R		...	R

RX 700 Series	ECE Entrata con albero pieno Solid input shaft Antrieb mit Vollwelle		PAM... IEC - Con campana senza giunto IEC - Motor bell without coupling IEC - mit Glocke ohne Kupplung	PAM..G IEC - Con campana e giunto IEC - Motor bell and coupling IEC - mit Glocke und Kupplung	PAM..R IEC-Con campana e giunto non elastico IEC - Motor bell and coupling not elastic IEC-mit Glocke und Kupplung mit keinem elastischen Teil							
	U	S	63 (B5)	71 (B5)	80 (B5)	90 (B5)	100 (B5)	112 (B5)	132 (B5)	160 (B5)	180 (B5)	200 (B5)
RXO1	712	24 j6	50									
RXV1	716	28 j6	60						PAM132 G*	PAM160 G*	PAM180 G*	
	720	38 k6	80						PAM132 G*	PAM160 G*	PAM180 G*	PAM200 G*

*Solo PAM...G - forniti con giunto tipo Rotex.

* Only PAM...G - come with Rotex coupling.

* nur PAM...G - Werden sie mit Kupplung Typ Rotex geliefert.

RX 700 Series	PAM...D IEC - Accoppiamento diretto IEC - Direct coupling IEC - Direkte Passung	
RXO-V1 712	132	38/300 (B5) - 38/200 (B14) - 38/250
	112	28/250 (B5) - 28/300 - 28/200
	100	28/250 (B5) - 28/300 - 28/200
	90	24/200 (B5) - 24/300 - 24/250
	80	19/200 (B5) - 19/300 - 19/250
RXO-V1 716 RXO-V1 720	132	38/300 (B5) - 38/200 (B14) - 38/250
	112	28/250 (B5) - 28/300 - 28/200
	100	28/250 (B5) - 28/300 - 28/200
	90	24/200 (B5) - 24/300 - 24/250
	80	19/200 (B5)

N.B: Per ulteriori accoppiamenti non previsti a catalogo consultare il ns. servizio tecnico commerciale.

NOTE: For coupling with motors not listed in this catalogue, please contact our Sales Engineers.

HINWEIS: Für weitere, nicht im Katalog enthaltene Passungen, bitten wir Sie sich mit unseren Technischen Kundendienst in Verbindung zu setzen.





Designazione motore elettrico Se è richiesto un motoriduttore completo di motore è necessario riportare la designazione di quest'ultimo. A tale proposito consultare il ns. catalogo dei motori elettrici Electronic Line.	Electric motor designation For applications requiring a gearmotor, motor designation must be specified. To this end, please refer to our Electronic Line electric motor catalogue.	Bezeichnung des Elektromotors Wird ein Getriebemotor komplett mit Elektromotor angefordert, müssen dessen Daten angegeben werden. Diesbezüglich verweisen wir auf unseren Katalog der Elektromotoren "Electronic Line".
---	---	--

1.7 Designazione

1.7 Designation

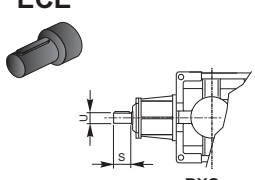
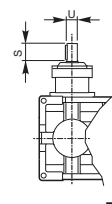
1.7 Bezeichnung

RX 800 Series	06 IV Versione Entrata Input Version Antriebsausführung	07 IS Albero Entrata Input Shaft Antriebswelle	08 IECT Tipo IEC e Albero Entrata IEC type and Input Shaft IEC Typ und Antriebswelle
ECE	ECE	—	—
PAM..	PAM	80	—
PAM..G		90	G
		...	

RX 800 Series	ECE		RXO		RXV		PAM...		PAM..G		IEC - Con campana senza giunto IEC - Motor bell without coupling IEC - mit Glocke ohne Kupplung	IEC - Con campana e giunto IEC - Motor bell and coupling IEC - mit Glocke und Kupplung									
		Entrata con albero pieno Solid input shaft Antrieb mit Vollwelle																			
	U	S					71 B5	80 B5	90 B5	100 B5	112 B5	132 B5	160 B5	180 B5	200 B5	225 B5	250 B5	280 B5	315 B5	355 B5	
RXO2	802	22 j6	40																		
RXV2	804	24 j6	45																		
	806	28 j6	50																		
	808	32 k6	56																		
	810	35 k6	63																		
	812	40 k6	70																		
	814	45 k6	80																		
	816	50 k6	90																		
	818	55 m6	100																		
	820	60 m6	112																		

Designazione motore elettrico Se è richiesto un motoriduttore completo di motore è necessario riportare la designazione di quest'ultimo. A tale proposito consultare il ns. catalogo dei motori elettrici Electronic Line.	<i>Electric motor designation</i> For applications requiring a gearmotor, motor designation must be specified. To this end, please refer to our Electronic Line electric motor catalogue.	Bezeichnung des Elektromotors Wird ein Getriebemotor komplett mit Elektromotor angefordert, müssen dessen Daten angegeben werden. Diesbezüglich verweisen wir auf unseren Katalog der Elektromotoren "Electronic Line".
---	--	--

1.7 Designazione

1.7 Designation

1.7 Bezeichnung

09 CM - Materiale carcassa

CM - Housing material

CM - Gehäusematerial

RX 700 - Series

RXO1 - RXV1

Materiale carcassa / Housing material Gehäusematerial		712	716	720
Ghisa meccanica / Engineering cast iron Maschinenguss	G			

RX 800 - Series

RXO2 - RXV2

Materiale carcassa / Housing material Gehäusematerial		802	804	806	808	810	812	814	816	818	820
Ghisa meccanica / Engineering cast iron Maschinenguss	G	"Standard"									
Ghisa sferoidale / Spheroidal cast iron Sphäroguss	GS	"On request"									

10 OS - Estremità uscita



OS - Output shaft

OS - Wellenende - Abtrieb

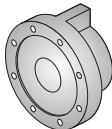
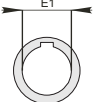
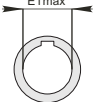
RX 700 Series

 EST	E1 Standard		E1 max		Tipo cuscinetto reggispinta Thrust bearing type Typ des Drucklagers
	712	∅ 28xL70		38	
716	∅ 32xL90		38		29412
720	∅ 32xL90		50		29415

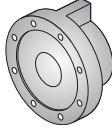
RX 800 Series

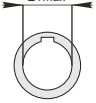
 EST	E1 Standard		E1 max		Tipo cuscinetto reggispinta Thrust bearing type Typ des Drucklagers
	802	∅ 32xL80		50	
804	∅ 38xL80		60		29417
806	∅ 42xL80		70		29420
808	∅ 48xL110		80		29424
810	∅ 60xL110		90		29428
812	∅ 70xL140		100		29430
814	∅ 80xL140		120		29434
816	∅ 90xL160		130		29436
818	∅ 100xL180		140		29440
820	∅ 110xL200		150		29452

11 MP - Posizioni di montaggio

MP - Mounting positions

MP - Einbaulagen

RX 700 Series	Per ulteriori informazioni vedere 1.8 For more details, please read 1.8 Sie können Weitere Informationen siehe 1.8
RX 800 Series	

1.7 Designazione

1.7 Designation

1.7 Bezeichnung

12 OPT-ACC. - Opzioni

OPT-ACC. - Options

OPT-ACC. - Optionen

RX 700	OPT	Code			
		VT	Paraoli in Viton in entrata e in uscita	Viton oil seals at input and output end	Ölabdichtungen aus Viton am An- und Abtrieb
		VT1	Paraoli in Viton in entrata	Viton oil seals at input end	Ölabdichtungen aus Viton am Antrieb
		VT2	Paraoli in Viton in uscita	Viton oil seals at output end	Ölabdichtungen aus Viton am Abtrieb

Per ulteriori informazioni vedere **SEZIONE U**
For more details, please read **SECTION U**
Sie können Weitere Informationen siehe **ABSCHNITT U**

RX 800	ACC5	Code			
		RFWn	Raffreddamento acqua-olio	Water/oil cooling	Wasser-/Ölkühlung
		RFAAn	Raffreddamento aria-olio	Air/oil cooling	Luft-/Ölkühlung
	ACC6	LF	Predisposizione per lubrificazione forzata	Provisions for forced lubrication	Auslegung für Zwangsschmierung
		LFMn	Lubrificazione forzata con motopompa (Std)	Forced lubrication with motor pump (Std)	Zwangsschmierung mit Motorpumpe (Std)
		LFPn	Lubrificazione forzata con pompa asservita (a rich.)	Forced lubrication with shaft driven pump (on request)	Zwangsschmierung mit Nebenpumpe (auf Anfr.)
	ACC7	AI	Accessori idraulici	Hydraulic accessories	Hydraulisches Zubehör
	ACC8	DT1	Doppia tenuta in entrata	Double seal at input end	Doppelte Dichtung am Antrieb
	OPT	VT	Paraoli in Viton in entrata e in uscita	Viton oil seals at input and output end	Ölabdichtungen aus Viton am An- und Abtrieb
		VT1	Paraoli in Viton in entrata	Viton oil seals at input end	Ölabdichtungen aus Viton am Antrieb
VT2		Paraoli in Viton in uscita	Viton oil seals at output end	Ölabdichtungen aus Viton am Abtrieb	
ACC9	IS	Coperchio d'ispezione	Inspection cover	Inspektionsdeckel	

Per ulteriori informazioni vedere **SEZIONE U**
For more details, please read **SECTION U**
Sie können Weitere Informationen siehe **ABSCHNITT U**

13 PMT - Posizioni della Morsetteria

PMT - Position Terminal Box

PMT - Montagposition Klemmenkasten

[2, 3, 4] Posizione della morsetteria del motore se diversa da quella standard (1).

[2, 3, 4] Position of the motor terminal box if different from the standard one (1).

Montageposition Klemmenkasten [2, 3, 4], wenn abweichend von Standardposition [1] (für Motorgetriebe).

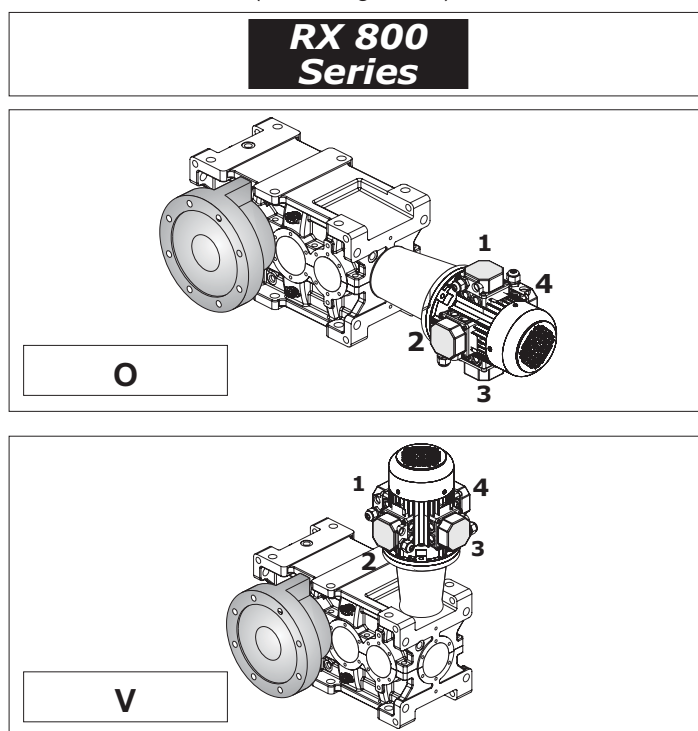
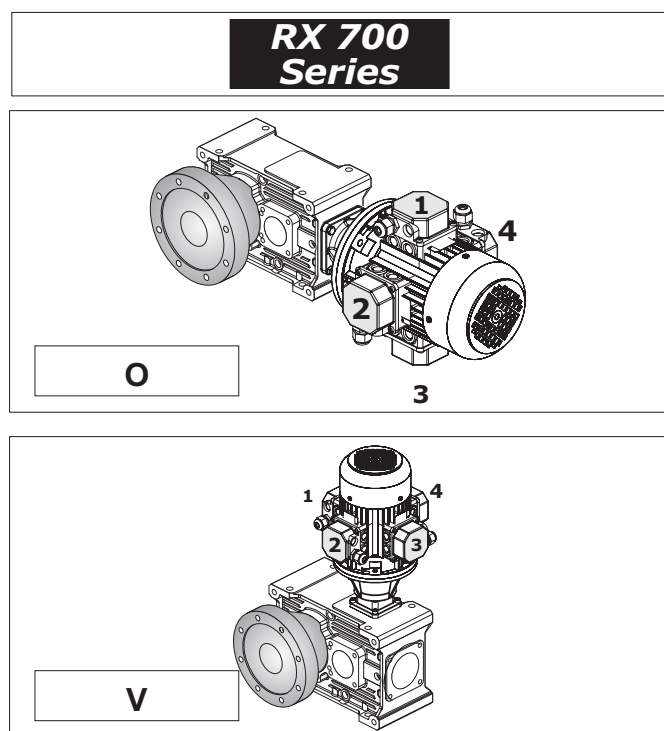

1.8 Lubrificazione

Gli oli disponibili appartengono generalmente a tre grandi famiglie:

- 1) Oli minerali
- 2) Oli sintetici Poli-Alfa-Olefine
- 3) Oli sintetici Poli-Glicole

La scelta più appropriata è generalmente legata alle condizioni di impiego. riduttori non particolarmente caricati e con un ciclo di impiego discontinuo, senza escursioni termiche importanti, possono certamente essere lubrificati con olio minerale.

Nei casi di impiego gravoso, quando i riduttori saranno prevedibilmente caricati molto ed in modo continuativo, con conseguente prevedibile innalzamento della temperatura, è bene utilizzare lubrificanti sintetici tipo polialfaolefine (PAO).

Gli oli di tipo poliglicole (PG) sono da utilizzare strettamente nel caso di applicazioni con forti strisciamenti fra i contatti, ad esempio nelle viti senza fine. Debbono essere impiegati con grande attenzione poiché non sono compatibili con gli altri oli e sono invece completamente miscibili con l'acqua. Questo fenomeno è particolarmente pericoloso poiché non si nota, ma deprime velocemente le caratteristiche lubrificanti dell'olio.

Oltre a questi già menzionati, ricordiamo che esistono gli oli per l'industria alimentare. Questi trovano specifico impiego nell'industria alimentare in quanto sono prodotti speciali non nocivi alla salute. Vari produttori forniscono oli appartenenti a tutte le famiglie con caratteristiche molto simili. Più avanti proponiamo una tabella comparativa.

1.8 Lubrication

Available oils are typically grouped into three major classes:

- 1) Mineral oils
- 2) Poly-Alpha-Olefin synthetic oils
- 3) Polyglycol synthetic oils

Oil is normally selected in accordance with environmental and operating conditions. Mineral oil is the appropriate choice for moderate load, non-continuous duty applications free from temperature extremes.

In severe applications, where gear units are to operate under heavy loads in continuous duty and high temperatures are expected, synthetic Poly-Alpha-Olefin oils (PAO) are the preferred choice.

Polyglycol oils (PG) should only be used in applications involving high sliding friction, as is the case with worm shafts. These particular oils should be used with great care, as they are not compatible with other oils, but are totally mixable with water. The oil mixed with water cannot be told from uncontaminated oil, but will degrade very rapidly.

In addition to the oils mentioned above, there are food-grade oils. These are special oils harmless to human health for use in the food industry. Oils with similar characteristics are available from a number of manufacturers. A comparative overview table is provided at the next pages.

1.8 Schmierung

Die verfügbaren Öle gehören im Allgemeinen drei großen Familien an:

- 1) Mineralöle
- 2) Polyalphaolefine-Synthetiköle
- 3) Polyglykol-Synthetiköle

Die angemessene Wahl ist im Allgemeinen an die Einsatzbedingungen gebunden. Getriebe, die keinen besonders schweren Belastungen ausgesetzt sind und einem unregelmäßigen Einsatzzyklus unterliegen, ohne starke thermische Ausschläge, können problemlos mit Mineralöl geschmiert werden.

Bei einem Einsatz unter harten Bedingungen, d.h. wenn die Getriebe stark und andauernd belastet werden, woraus sich ein sicherer Temperaturanstieg ergibt, sollten Synthetiköle, Typ Polyalphaolefine (PAO), verwendet werden.

Die Öle, Typ Polyglykole (PG), sind ausschließlich für einen Einsatz ausgelegt, bei denen es zu starken Reibungen zwischen den in Kontakt stehenden Elementen kommt, z.B. bei Schnecken. Bei ihrem Einsatz in besondere Aufmerksamkeit erforderlich, da sie nicht mit anderen Ölen kompatibel sind, sich jedoch vollständig mit Wasser vermischen lassen. Diese Tatsache erweist sich daher als besonders gefährlich, da sie sich nicht feststellen lässt, jedoch die Schmiereigenschaften des Öls bereits nach kurzer Zeit unterdrückt.

Über die bereits genannten Öle hinaus, gibt es auch Öle, die speziell für die Lebensmittelindustrie ausgelegt sind. Diese finden demzufolge dort ihren Einsatz, da es sich dabei um spezielle Produkte handelt, die für die Gesundheit unschädlich sind. Die den jeweiligen Familien angehörigen Ölsorten werden von verschiedenen Herstellern angeboten; sie weisen jeweils sehr ähnliche Eigenschaften auf. Auf der folgenden Seite finden Sie eine entsprechende Vergleichstabelle.

Input speed n_1 (min ⁻¹)	Absorbed power (kW)	Lubrication system	Viscosity ISO VG at 40° (cSt)	
			$i \leq 10$	$i > 10$
$2000 < n_1 \leq 5000$	$P < 7.5$	Forced or Oil splash	68	68
	$7.5 \leq P \leq 22$		68	150
	$P > 22$		150	220
$1000 < n_1 \leq 2000$	$P < 7.5$	Forced or Oil splash	68	150
	$7.5 \leq P \leq 37$		150	220
	$P > 37$		220	320
$300 < n_1 \leq 1000$	$P < 15$	Forced Oil splash	68	150
	$15 \leq P \leq 55$	Forced Oil splash	150	220
		Forced Oil splash	220	320
		Forced Oil splash	320	460
$50 < n_1 \leq 300$	$P < 22$	Forced Oil splash	150	220
	$22 \leq P \leq 75$	Forced Oil splash	220	320
		Forced Oil splash	320	460
		Forced Oil splash	460	680

1.8 Lubrificazione

Nel caso di lubrificazione forzata con pompa, qualora siano richieste ISO VG > 220 e/o temperature < 10°C, consultarci.

La tabella è valida per velocità periferiche normali; in caso di velocità > 13m/s, consultarci.

Se la temperatura ambiente T < 0°C ridurre di una gradazione la viscosità prevista in tabella, viceversa aumentarla di una se T > 40°C.

Le temperature ammissibili per gli oli minerali sono:
(-10 = T = 90)°C (fino a 100°C per periodi limitati).

Le temperature ammissibili per gli oli sintetici sono:
(-20 = T = 110)°C (fino a 120°C per periodi limitati).

Per temperature dell'olio esterne a quelle ammissibili per il minerale e per aumentare l'intervallo di sostituzione del lubrificante adottare olio sintetico a base di polialfaolefine.

1.8 Lubrication

In case of forced lubrication by pump, when ISO VG > 220 and/or temperatures < 10°C, are requested, it is advisable to contact us.

The table is valid for normal peripheral speeds; in case of speed > 13 m/s, contact us.

If the environment temperature T < 0°C, decrease viscosity class by one, vice versa increase by one if T > 40°C.

Permissible temperatures for mineral oil are:

(-10 = T = 90)°C, up to 100°C for a short time.

Permissible temperatures for synthetic oil are:
(-20 = T = 110)°C, up to 120°C for a short time.

If the oil temperature is not permissible for mineral oil and for decreasing frequency of oil change, use synthetic oil with polyalphaolefins (PAOs).

1.8 Schmierung

Im Fall einer Zwangsschmierung über eine Pumpe, falls die ISO VG > 220 und/oder Temperaturen < 10°C gefordert werden, setzen Sie sich bitte mit uns in Verbindung.

Die Tabelle ist für normale Umfangsgeschwindigkeiten gültig. Bei Geschwindigkeiten > 13m/s, setzen Sie sich bitte mit uns in Verbindung.

Bei einer Umgebungstemperatur T < 0°C den von der Tabelle vorgesehenen Viskositätsgrad um eine Gradation mindern und, im entgegengesetzten Fall, bei einer Temperatur T > 40°C, um eine anheben.

Für Mineralöl zulässige Temperaturen:

(-10 = T = 90) °C (bis 100°C über begrenzte Zeiträume).

Für Synthetiköl zulässige Temperaturen:

(-20 = T = 110) °C (bis 120°C über begrenzte Zeiträume).

Bei Temperaturen, die diese für Mineralöle zulässigen Werte überschreiten und um die Auswechselzeiten verlängern zu können, sollte Synthetiköl auf Basis von Polyalphaolefinen verwendet werden.

Produttore Manufacturer Hersteller	Oli Minerali Mineral oils Mineralöle			Oli Sintetici Polialfaolefine (PAO) Poly-Alpha-Olefin synthetic oils (PAO) Polyalphaolefine- Synthetiköle (PAO)			Oli Sintetici Poliglicoli (PG) Polyglycol synthetic oils (PG) Polyglykol-Synthetiköle (PG)		
	ISO VG	ISO VG	ISO VG	ISO VG	ISO VG	ISO VG	ISO VG	ISO VG	ISO VG
	150	220	320	150	220	320	150	220	320
AGIP	Blasia 150	Blasia 220	Blasia 320	-	Blasia SX 220	Blasia SX 320	Blasia S 150	Blasia S 220	Blasia S 320
ARAL	Degol BG 150 Plus	Degol BG 220 Plus	Degol BG 320 Plus	Degol PAS 150	Degol PAS 220	Degol PAS 320	Degol GS 150	Degol GS 220	Degol GS 320
BP	Energol GR-XP 150	Energol GR-XP 220	Energol GR-XP 320	Energol EPX 150	Energol EPX 220	Energol EPX 320	Energol SG 150	Energol SG-XP 220	Energol SG-XP 320
CASTROL	Alpha SP 150	Alpha SP 220	Alpha SP 320	Alphasyn EP 150	Alphasyn EP 220	Alphasyn EP 320	Alphasyn PG 150	Alphasyn PG 220	Alphasyn PG 320
CHEVRON	Ultra Gear 150	Ultra Gear 220	Ultra Gear 320	Tegra Synthetic Gear 150	Tegra Synthetic Gear 220	Tegra Synthetic Gear 320	HiPerSYN 150	HiPerSYN 220	HiPerSYN 320
ESSO	Spartan EP 150	Spartan EP 220	Spartan EP 320	Spartan S EP 150	Spartan S EP 220	Spartan S EP 320	Glycolube 150	Glycolube 220	Glycolube 320
KLÜBER	Klüberoil GEM 1-150	Klüberoil GEM 1-220	Klüberoil GEM 1-320	Klübersynth EG 4-150	Klübersynth EG 4-220	Klübersynth EG 4-320	Klübersynth GH 6-150	Klübersynth GH 6-220	Klübersynth GH 6-320
MOBIL	Mobilgear XMP 150	Mobilgear XMP 220	Mobilgear XMP 320	Mobilgear SHC XMP 150	Mobilgear SHC XMP 220	Mobilgear SHC XMP 320	Glygoyle 22	Glygoyle 30	Glygoyle HE320
MOLIKOTE	L-0115	L-0122	L-0132	L-1115	L-1122	L-1132	-	-	-
OPTIMOL	Optigear BM 150	Optigear BM 220	Optigear BM 320	Optigear Synthetic A 150	Optigear Synthetic A 220	Optigear Synthetic A 320	Optiflex A 150	Optiflex A 220	Optiflex A 320
Q8	Goya 150	Goya 220	Goya 320	El Greco 150	El Greco 220	El Greco 320	Gade 150	Gade 220	Gade 320
SHELL	OMALA S2 G 150	OMALA S2 G 220	OMALA S2 G 320	Omala S4 GX 150	Omala S4 GX 220	Omala S4 GX 320	OMALA S4 WE 150	OMALA S4 WE 220	OMALA S4 WE 320
TEXACO	Meropa 150	Meropa 220	Meropa 320	Pinnacle EP 150	Pinnacle EP 220	Pinnacle EP 320	-	Synlube CLP 220	Synlube CLP 320
TOTAL	Carter EP 150	Carter EP 220	Carter EP 320	Carter SH 150	Carter SH 220	Carter SH 320	Carter SY 150	Carter SY 220	Carter SY 320
TRIBOL	1100/150	1100/220	1100/320	1510/150	1510/220	1510/320	800\150	800\220	800\320

Lubrificanti sintetici per uso alimentare / Food-grade synthetic lubricants / Schmiermittel Synthetik für Lebensmittelbereich

AGIP				Rocol Foodlube Hi-Torque 150	—	Rocol Foodlube Hi-Torque 320			
ESSO				—	Gear Oil FM 220	—			
KLÜBER				Klüberoil 4 UH1 N 150	Klüberoil 4 UH1 N 220	Klüberoil 4 UH1 N 320			
MOBIL				DTE FM 150	DTE FM 220	DTE FM 320			
SHELL				Cassida Fluid GL 150	Cassida Fluid GL 220	Cassida Fluid GL 320			

1.8 Lubrificazione
Posizioni di montaggio

1.8 Lubrication
Mounting positions

1.8 Schmierung
Einbaulagen

RX 700 - Series

			RXO			
M1	M2	M3		A-AS		
				RXV		
M4	M5	M6			B-BS	
					RXV	
M1	M2	M3				A-AS
			RXV			
M4	M5	M6				B-BS

▽ Carico / Filler plug / Einfüllschraube
▼ Scarico / Drain plug / Ablassschraube
● Livello / Level plug / Schauglas

1.8 Lubrificazione

1.8 Lubrication

1.8 Schmierung

Quantità di lubrificante / Lubricant quantity / Schmiermittelmenge [Kg]											
RX 700 Series		Posizione di montaggio Mounting position Einbaulage						Stato di fornitura State of supply Lieferzustand		N° tappi No. of plugs Anzahl Betriebschraubei	Posizione di montaggio Mounting position Montageposition
		M1	M2	M3	M4	M5	M6				
RXO1	712	2.20	2.20	2.50	2.50	2.60	2.60	Riduttori predisposti per lubrificazione ad olio * Gearboxes supplied ready for oil lubrication Getriebe sind für Ölschmierung vorgesehen		8	Necessaria Necessary Erforderlich
	716	4.00	4.00	4.40	4.40	4.50	4.50				
	720	9.10	9.10	10.2	10.5	13.3	13.3				

Quantità di lubrificante / Lubricant quantity / Schmiermittelmenge [Kg]											
RX 700 Series		Posizione di montaggio Mounting position Einbaulage						Stato di fornitura State of supply Lieferzustand		N° tappi No. of plugs Anzahl Betriebschraubei	Posizione di montaggio Mounting position Montageposition
		M1	M2	M3	M4	M5	M6				
RXV1	712	2.20	2.20	2.50	2.50	2.60	2.60	Riduttori predisposti per lubrificazione ad olio * Gearboxes supplied ready for oil lubrication Getriebe sind für Ölschmierung vorgesehe		8	Necessaria Necessary Erforderlich
	716	4.00	4.00	4.40	4.40	4.50	4.50				
	720	9.10	9.10	10.2	10.5	13.3	13.3				

Le quantità di olio sono approssimative; per una corretta lubrificazione occorre fare riferimento al livello segnato sul riduttore.

Oil quantities listed in the table are approximate; to ensure correct lubrication, please refer to the level mark on the gear unit.

Bei den Ölmengeangaben handelt es sich um approximative Werte; für den Erhalt einer korrekten Schmierung muss Bezug auf den am Getriebe gekennzeichneten Füllstand genommen werden.

*Su richiesta possono essere forniti completi di lubrificante sintetico del tipo OMA LA S4 WE 320.

*On request they can be supplied oil filled with synthetic lubricant OMA LA S4 WE 320.

*Auf Anfrage können Sie mit synthetischem Öl Typ OMA LA S4 WE 320 geliefert werden.

ATTENZIONE

Il tappo di sfiato è allegato solo nei riduttori che hanno più di un tappo olio.

WARNING

A breather plug is supplied only with gearboxes that have more than one oil plug.

ACHTUNG

Der Entlüftungsstopfen ist lediglich bei den Getrieben vorhanden, die über mehr als einen Ölfüllstopfen verfügen.

Eventuali forniture con predisposizioni tappi diverse da quella indicata in tabella, dovranno essere concordate.

The supply of gearboxes with different plug pre-arrangements has to be agreed with the manufacturer.

Lieferungen, die eine Auslegung hinsichtlich der Stopfen aufweisen, die von den Angaben in der Tabelle abweichen, müssen vorab vereinbart werden.

Nei riduttori dove è necessario specificare la posizione di montaggio, la posizione richiesta è indicata nella targhetta del riduttore.

The gearboxes that need a specific assembling position have the indication of it on the label of the gearbox.

In den Getrieben in dem man die Montage Position angeben soll, findet man die angefragte Position auf dem Typenschild des Getriebes.

1.8 Lubrificazione

1.8 Lubrication

1.8 Schmierung

Posizioni di montaggio

Mounting positions

Einbaulagen

RX 800 - Series

			RXO			
M1	M2	M3				
				RXV		
M4	M5	M6				
					RXO	
M1	M2	M3				
			RXV			
M4	M5	M6				

▽ Carico / Filler plug / Einfüllschraube
 ▼ Scarico / Drain plug / Ablassschraube
 ● Livello / Level plug / Schauglas

1.8 Lubrificazione

1.8 Lubrication

1.8 Schmierung

RX 800 Series		Quantità di lubrificante / Lubricant Quantity / Schmiermittelmenge (l)									
		802	804	806	808	810	812	814	816	818	820
RXO2 RXV2	M1 - M2	3,3	4,7	6,5	9,0	13,0	18,0	25,0	35,0	49,0	69,0
	M3	6,1	8,6	12,0	17,0	24,0	34,0	48,0	68,0	95,0	133,0
	M4	5,1	7,2	10,0	15,0	20,0	29,0	40,0	56,0	80,0	114,0
	M5 - M6	4,6	6,5	9,4	13,0	18,0	25,0	35,0	50,0	70,0	99,0

Le quantità di olio sono approssimative; per una corretta lubrificazione occorre fare riferimento al livello segnato sul riduttore.

ATTENZIONE

Eventuali forniture con predisposizioni tappi diverse da quella indicata in tabella, dovranno essere concordate.

Oil quantities listed in the table are approximate; to ensure correct lubrication, please refer to the level mark on the gear unit.

WARNING

Any plug arrangements other than that indicated in the table must be agreed upon.

Bei den Ölmengeangaben handelt es sich um approximative Werte; für den Erhalt einer korrekten Schmierung muss Bezug auf den am Getriebe gekennzeichneten Füllstand genommen werden.

ACHTUNG

Eventuelle Lieferungen mit einer von den Tabellenangaben abweichenden Anordnung der Stopfen müssen zuvor abgestimmt werden.

Lubrificazione cuscinetti superiori

Upper bearing lubrication

Schmierung der obenliegenden Lager

La lubrificazione forzata dei cuscinetti superiori viene associata alla lubrificazione forzata degli ingranaggi nel caso quest'ultima sia necessaria.

Forced lubrication for upper bearings is normally associated with forced lubrication for the gears, where necessary.

Die Zwangsschmierung der obenliegenden Lager wird mit der Zwangsschmierung der Zahnräder, für die sind, assoziiert.

Pos. Mont. / Mntg. Pos. / Einbaulage M1- M5 - M6

RXO RXV	M5 M6	n ₁ [min ⁻¹]	Grandezza / Size / Baugröße							
			802-810	812	814	816	818	820		
RXO2 RXV2		1751 - n _{1max}	G (grease)		LFM2			LFM2		
		1000 - 1750	G (grease)							
		0 - 999	G (grease)							

Pos. Mont. / Mntg. Pos. / Einbaulage M3 - M4

	n ₁ [min ⁻¹]	Grandezza / Size / Baugröße						
		802-808	810	812	814	816	818	820
RXO2 RXV2	1751 - n _{1max}	G (grease)	G (grease)			LFM1		
	1000 - 1750	G (grease)	G (grease)				LFM1	
	0 - 999	G (grease)	G (grease)					LFM1

I valori di n_{1max} sono riportati nel paragrafo Verifiche, punto 4.

n_{1max} values are listed at paragraph Verification, point 4.

Die Werte von n_{1max} werden im Paragraph "Kontrollen", Punkt 4, angegeben.

	l/min	Motor	P (kW)	A
LFM1	0.5	71A4	0.25	172
LFM2	5			
LFM2				

LFM.: Motopompa (vedi sezione U accessori e opzioni).

LFM.: Motor pump (see Section Accessories and Options U).

LFM.: Motorpumpe (siehe Abschnitt "Zubehör und Optionen U).

RX 700 ECE-45 PAM-51 712							ECE-76 PAM-86 716					
n_1 min ⁻¹	ir	n_2 min ⁻¹	P_N kW	T_N Nm	Fr_1 N	Fa_2 kN	ir	n_2 min ⁻¹	P_N kW	T_N Nm	Fr_1 N	Fa_2 kN
2850	5.2	553.3	27.9	457.9	800	40	5.2	553.3	55.8	915.8	1250	40
1450		281.5	15.5	500.0	1600	49		281.5	31.0	1000.0	2500	49
1000		194.1	10.9	507.5	1600	55		194.1	21.7	1015.0	2500	55
500		97.1	5.4	507.5	1600	67		97.1	10.9	1015.0	2500	67
2850	7.4	384.4	29.5	696.0	800	44	7.4	384.4	50.4	1190.5	1250	44
1450		195.6	16.4	760.0	1600	54		195.6	28.0	1300.0	2500	54
1000		134.9	11.5	771.4	1600	60		134.9	19.6	1319.5	2500	61
500		67.4	5.7	771.4	1600	74		67.4	9.8	1319.5	2500	75
2850	10.0	286.0	28.3	897.5	800	49	10.2	280.6	51.0	1648.4	1250	49
1450		145.5	15.7	980.0	1600	60		142.7	28.3	1800.0	2500	60
1000		100.3	11.0	994.7	1600	67		98.4	19.8	1827.0	2500	67
500		50.2	5.5	994.7	1600	82		49.2	9.9	1827.0	2500	82
2850	12.2	234.3	23.7	915.8	800	51	12.2	234.3	44.9	1740.0	1250	52
1450		119.2	13.1	1000.0	1600	63		119.2	25.0	1900.0	2500	63
1000		82.2	9.2	1015.0	1600	70		82.2	17.5	1928.5	2500	71
500		41.1	4.6	1015.0	1600	86		41.1	8.7	1928.5	2500	87
2850	14.6	194.7	19.7	915.8	800	55	14.6	194.7	39.3	1831.6	1250	55
1450		99.1	10.9	1000.0	1600	67		99.1	21.8	2000.0	2500	67
1000		68.3	7.6	1015.0	1600	75		68.3	15.3	2030.0	2500	75
500		34.2	3.8	1015.0	1600	92		34.2	7.6	2030.0	2500	92
2850	17.0	168.0	18.7	1007.4	800	57	17.0	168.0	33.9	1831.6	1250	57
1450		85.5	10.4	1100.0	1600	69		85.5	18.8	2000.0	2500	70
1000		59.0	7.3	1116.5	1600	78		59.0	13.2	2030.0	2500	78
500		29.5	3.6	1116.5	1600	96		29.5	6.6	2030.0	2500	96
2850	21.2	134.4	14.9	1007.4	800	61	21.2	134.4	28.5	1923.2	1250	61
1450		68.4	8.3	1100.0	1600	75		68.4	15.8	2100.0	2500	75
1000		47.1	5.8	1116.5	1600	83		47.1	11.1	2131.5	2500	83
500		23.6	2.9	1116.5	1600	103		23.6	5.5	2131.5	2500	103
2850	24.6	115.9	11.7	915.8	650	63	24.6	115.9	24.6	1923.2	1000	64
1450		59.0	6.5	1000.0	1250	78		59.0	13.7	2100.0	2000	78
1000		40.7	4.6	1015.0	1250	87		40.7	9.6	2131.5	2000	87
500		20.3	2.3	1015.0	1250	107		20.3	4.8	2131.5	2000	107
2850	31.0	91.9	9.3	915.8	650	68	31.9	89.2	18.0	1831.6	1000	69
1450		46.7	5.2	1000.0	1250	84		45.4	10.0	2000.0	2000	84
1000		32.2	3.6	1015.0	1250	94		31.3	7.0	2030.0	2000	94
500		16.1	1.8	1015.0	1250	115		15.7	3.5	2030.0	2000	116
2850	40.5	70.4	7.1	915.8	650	74	40.5	70.4	14.2	1831.6	1000	74
1450		35.8	4.0	1000.0	1250	90		35.8	7.9	2000.0	2000	91
1000		24.7	2.8	1015.0	1250	101		24.7	5.5	2030.0	2000	101
500		12.4	1.4	1015.0	1250	124		12.4	2.8	2030.0	2000	125
2850	51.0	55.8	5.6	915.8	500	79	52.6	54.2	10.9	1831.6	800	80
1450		28.4	3.1	1000.0	1000	97		27.6	6.1	2000.0	1600	98
1000		19.6	2.2	1015.0	1000	109		19.0	4.3	2030.0	1600	110
500		9.8	1.1	1015.0	1000	134		9.5	2.1	2030.0	1600	135
2850	58.0	49.1	5.0	915.8	500	82	58.0	49.1	9.9	1831.6	800	82
1450		25.0	2.8	1000.0	1000	100		25.0	5.5	2000.0	1600	101
1000		17.2	1.9	1015.0	1000	112		17.2	3.9	2030.0	1600	113
500		8.6	1.0	1015.0	1000	138		8.6	1.9	2030.0	1600	139
2850	73.2	38.9	3.9	915.8	500	88	75.4	37.8	7.6	1831.6	800	89
1450		19.8	2.2	1000.0	1000	108		19.2	4.2	2000.0	1600	109
1000		13.7	1.5	1015.0	1000	121		13.3	3.0	2030.0	1600	122
500		6.8	0.8	1015.0	1000	149		6.6	1.5	2030.0	1600	150
Potenze termiche / Thermal power / Termische Grenzleistung P_{IN} [kW] (senza raffreddamento / Without cooling / ohne Kühlung)												
16.5							25					

1.9 Prestazioni riduttori RXO-RXV

1.9 RXO-RXV gear unit ratings

1.9 Leistungen der RXO-V Getriebe



RX 700		 ECE-177 PAM-194	720			
n_{1-1} min ⁻¹	ir	n_2 min ⁻¹	P_N kW	T_N Nm	Fr_1 N	Fa_2 kN
2850	7.6	375.6	151.6	3663.2	2000	66
1450		191.1	84.2	4000.0	4000	81
1000		131.8	59.0	4060.0	4000	91
500		65.9	29.5	4060.0	4000	112
2850	10.3	277.1	111.9	3663.2	2000	73
1450		141.0	62.2	4000.0	4000	89
1000		97.2	43.5	4060.0	4000	100
500		48.6	21.8	4060.0	4000	123
2850	12.3	232.5	96.2	3754.7	2000	77
1450		118.3	53.5	4100.0	4000	94
1000		81.6	37.4	4161.5	4000	105
500		40.8	18.7	4161.5	4000	129
2850	14.9	190.7	80.8	3846.3	2000	81
1450		97.0	44.9	4200.0	4000	100
1000		66.9	31.4	4263.0	4000	111
500		33.5	15.7	4263.0	4000	137
2850	20.2	141.1	59.8	3846.3	2000	89
1450		71.8	33.2	4200.0	4000	109
1000		49.5	23.3	4263.0	4000	122
500		24.8	11.6	4263.0	4000	150
2850	24.6	115.8	50.2	3937.9	2000	94
1450		58.9	27.9	4300.0	4000	116
1000		40.6	19.5	4364.5	4000	129
500		20.3	9.8	4364.5	4000	159
2850	33.4	85.4	37.9	4029.5	2000	103
1450		43.4	21.1	4400.0	4000	127
1000		30.0	14.7	4466.0	4000	142
500		15.0	7.4	4466.0	4000	174
2850	40.7	70.0	29.0	3754.7	2000	110
1450		35.6	16.1	4100.0	4000	135
1000		24.6	11.3	4161.5	4000	150
500		12.3	5.6	4161.5	4000	185
2850	51.3	55.6	25.2	4121.1	2000	118
1450		28.3	14.0	4500.0	4000	144
1000		19.5	9.8	4567.5	4000	161
500		9.7	4.9	4567.5	4000	198
2850	57.4	49.6	21.0	3846.3	2000	122
1450		25.3	11.7	4200.0	4000	149
1000		17.4	8.2	4263.0	4000	167
500		8.7	4.1	4263.0	4000	205
2850	72.3	39.4	15.9	3663.2	2000	131
1450		20.1	8.8	4000.0	4000	160
1000		13.8	6.2	4060.0	4000	179
500		6.9	3.1	4060.0	4000	220
Potenze termiche / Thermal power / Termische Grenzleistung P_{TW} [kW] (senza raffreddamento / Without cooling / ohne Kühlung)						
39.0						



1.9 Prestazioni riduttori RXO-RXV

1.9 RXO-RXV gear unit ratings

1.9 Leistungen der RXO-V Getriebe

RX 800  111						802					 155					804					 210					806				
n_1 min ⁻¹	ir	n_2 min ⁻¹	P_N kW	T_N kNm	Fa_2 Fr_1 kN	ir	n_2 min ⁻¹	P_N kW	T_N kNm	Fa_2 Fr_1 kN	ir	n_2 min ⁻¹	P_N kW	T_N kNm	Fa_2 Fr_1 kN	ir	n_2 min ⁻¹	P_N kW	T_N kNm	Fa_2 Fr_1 kN	ir	n_2 min ⁻¹	P_N kW	T_N kNm	Fa_2 Fr_1 kN					
1450	19.4	75	27	3.2	109 1.8	19.4	75	39	4.6	125 2.0	20.5	71	56	7.0	154 3.1	20.5	71	56	7.0	154 3.1	20.5	71	56	7.0	154 3.1					
1000		52	18.6	3.2			52	27	4.7			49	39	7.1			49	39	7.1			49	39	7.1						
500		26	9.3	3.2			26	13.6	4.7			24	20	7.4			24	20	7.4			24	20	7.4						
1450	21.9	66	24	3.2	113 1.8	21.9	66	34	4.6	130 2.0	21.8	67	52	7.0	159 3.1	21.8	67	52	7.0	159 3.1	21.8	67	52	7.0	159 3.1					
1000		46	17.0	3.3			46	24	4.7			46	37	7.1			46	37	7.1			46	37	7.1						
500		23	8.7	3.4			23	12.6	4.9			23	19.1	7.4			23	19.1	7.4			23	19.1	7.4						
1450	24.9	58	22	3.3	117 1.9	24.9	58	31	4.7	135 2.2	24.6	59	46	7.0	165 3.2	24.6	59	46	7.0	165 3.2	24.6	59	46	7.0	165 3.2					
1000		40	14.9	3.3			40	22	4.8			41	33	7.2			41	33	7.2			41	33	7.2						
500		20	7.7	3.4			20	11.1	4.9			20	16.9	7.4			20	16.9	7.4			20	16.9	7.4						
1450	28.5	51	18.9	3.3	121 1.9	30.6	47	25	4.7	145 2.2	28.0	52	41	7.1	171 3.2	28.0	52	41	7.1	171 3.2	28.0	52	41	7.1	171 3.2					
1000		35	13.4	3.4			33	17.7	4.8			36	29	7.2			36	29	7.2			36	29	7.2						
500		17.6	6.9	3.5			16.4	9.2	5.0			17.9	15.1	7.5			17.9	15.1	7.5			17.9	15.1	7.5						
1450	30.6	47	17.6	3.3	121 2	32.9	44	23	4.7	150 2.2	30.0	48	39	7.1	177 3.4	30.0	48	39	7.1	177 3.4	30.0	48	39	7.1	177 3.4					
1000		33	12.5	3.4			30	16.4	4.8			33	27	7.2			33	27	7.2			33	27	7.2						
500		16.3	6.4	3.5			15.2	8.5	5.0			16.7	14.1	7.5			16.7	14.1	7.5			16.7	14.1	7.5						
1450	32.9	44	16.3	3.3	126 2	38.5	38	20	4.8	156 2.3	34.6	42	34	7.2	184 3.4	34.6	42	34	7.2	184 3.4	34.6	42	34	7.2	184 3.4					
1000		30	11.6	3.4			26	14.3	4.9			29	24	7.3			29	24	7.3			29	24	7.3						
500		15.2	6.0	3.5			13.0	7.3	5.0			14.4	12.3	7.6			14.4	12.3	7.6			14.4	12.3	7.6						
1450	38.6	38	13.9	3.3	135 2.1	41.9	35	18.7	4.8	160 2.3	37.4	39	31	7.2	184 3.6	37.4	39	31	7.2	184 3.6	37.4	39	31	7.2	184 3.6					
1000		26	9.9	3.4			24	13.1	4.9			27	22	7.3			27	22	7.3			27	22	7.3						
500		13.0	5.1	3.5			11.9	6.7	5.0			13.4	11.4	7.6			13.4	11.4	7.6			13.4	11.4	7.6						
1450	46.0	32	12.1	3.4	144 2.1	45.9	32	17.1	4.8	162 2.3	44.1	33	27	7.2	191 3.6	44.1	33	27	7.2	191 3.6	44.1	33	27	7.2	191 3.6					
1000		22	8.3	3.4			22	12.0	4.9			23	18.9	7.4			23	18.9	7.4			23	18.9	7.4						
500		10.9	4.3	3.5			10.9	6.1	5.0			11.3	9.7	7.6			11.3	9.7	7.6			11.3	9.7	7.6						
1450	49.6	29	11.2	3.4	144 2.1	49.5	29	15.8	4.8	167 2.3	52.1	28	23	7.3	204 3.6	52.1	28	23	7.3	204 3.6	52.1	28	23	7.3	204 3.6					
1000		20	7.7	3.4			20	11.1	4.9			19.2	16.0	7.4			19.2	16.0	7.4			19.2	16.0	7.4						
500		10.1	4.0	3.5			10.1	5.7	5.0			9.6	8.2	7.6			9.6	8.2	7.6			9.6	8.2	7.6						
1450	58.1	25	9.5	3.4	155 2.1	58.0	25	13.8	4.9	172 2.3	56.3	26	21	7.3	210 3.6	56.3	26	21	7.3	210 3.6	56.3	26	21	7.3	210 3.6					
1000		17.2	6.8	3.5			17.2	9.7	5.0			17.8	15.0	7.5			17.8	15.0	7.5			17.8	15.0	7.5						
500		8.6	3.4	3.5			8.6	4.9	5.0			8.9	7.6	7.6			8.9	7.6	7.6			8.9	7.6	7.6						
1450	63.3	23	8.8	3.4	155 2.2	63.1	23	12.7	4.9	179 2.5	66.3	22	18.2	7.4	220 3.8	66.3	22	18.2	7.4	220 3.8	66.3	22	18.2	7.4	220 3.8					
1000		15.8	6.2	3.5			15.8	8.9	5.0			15.1	12.7	7.5			15.1	12.7	7.5			15.1	12.7	7.5						
500		7.9	3.1	3.5			7.9	4.5	5.0			7.5	6.4	7.6			7.5	6.4	7.6			7.5	6.4	7.6						
1450	69.2	21	8.0	3.4	161 2.2	69.1	21	11.6	4.9	179 2.5	72.5	20	16.4	7.4	19 3.8	72.5	20	16.4	7.4	19 3.8	72.5	20	16.4	7.4	19 3.8					
1000		14.4	5.7	3.5			14.5	8.1	5.0			13.8	11.8	7.6			13.8	11.8	7.6			13.8	11.8	7.6						
500		7.2	2.8	3.5			7.2	4.1	5.0			6.9	5.9	7.6			6.9	5.9	7.6			6.9	5.9	7.6						
1450	81.5	17.8	7.0	3.5	167 2.2	81.3	17.8	9.8	4.9	190 2.5	79.8	18.2	15.3	7.5	230 3.8	79.8	18.2	15.3	7.5	230 3.8	79.8	18.2	15.3	7.5	230 3.8					
1000		12.3	4.8	3.5			12.3	6.9	5.0			12.5	10.7	7.6			12.5	10.7	7.6			12.5	10.7	7.6						
500		6.1	2.4	3.5			6.1	3.5	5.0			6.3	5.4	7.6			6.3	5.4	7.6			6.3	5.4	7.6						
1450	88.7	16.3	6.4	3.5	167 2.2	88.5	16.4	9.2	5.0	190 2.5	93.0	15.6	13.1	7.5	240 3.8	93.0	15.6	13.1	7.5	240 3.8	93.0	15.6	13.1	7.5	240 3.8					
1000		11.3	4.4	3.5			11.3	6.4	5.0			10.8	9.2	7.6			10.8	9.2	7.6			10.8	9.2	7.6						
500		5.6	2.2	3.5			5.7	3.2	5.0			5.4	4.6	7.6			5.4	4.6	7.6			5.4	4.6	7.6						
1450	97.1	14.9	5.9	3.5	173 2.2	96.8	15.0	8.4	5.0	199 2.5	102	14.3	12.2	7.6	260 3.8	102	14.3	12.2	7.6	260 3.8	102	14.3	12.2	7.6	260 3.8					
1000		10.3	4.1	3.5			10.3	5.8	5.0			9.8	8.4	7.6			9.8	8.4	7.6			9.8	8.4	7.6						
500		5.1	2.0	3.5			5.2	2.9	5.0			4.9	4.2	7.6			4.9	4.2	7.6			4.9	4.2	7.6						
1450	107	13.6	5.3	3.5	176 2.2	107	13.6	7.7	5.0	203 2.5	112	13.0	11.1	7.6	260 3.8	112	13.0	11.1	7.6	260 3.8	112	13.0	11.1	7.6	260 3.8					
1000		9.4	3.7	3.5			9.4	5.3	5.0			8.9	7.6	7.6			8.9	7.6	7.6			8.9	7.6	7.6						
500		4.7	1.8	3.5			4.7	2.6	5.0			4.5	3.8	7.6			4.5	3.8	7.6			4.5	3.8	7.6						
1450	118	12.2	4.8	3.5	184 2.2	118	12.3	6.9	5.0	212 2.5	124	11.7	10.0	7.6	265 3.8	124	11.7	10.0	7.6	265 3.8	124	11.7	10.0	7.6	265 3.8					
1000		8.5	3.3	3.5			8.5	4.8	5.0			8.1	6.9	7.6			8.1	6.9	7.6			8.1	6.9	7.6						
500		4.2	1.7	3.5			4.2	2.4	5.0			4.0	3.5	7.6			4.0	3.5	7.6			4.0	3.5	7.6						

Potenze termiche - Thermal power - Thermische Grenzleistung

(senza raffreddamento / Without cooling / ohne Kühlung)

24



30

40

1.9 Prestazioni riduttori RXO-RXV

1.9 RXO-RXV gear unit ratings

1.9 Leistungen der RXO-V Getriebe

RX 800  289 808						 396 810					 549 812				
n_1 min ⁻¹	ir	n_2 min ⁻¹	P_N kW	T_N kNm	Fa_2 Fr_1 kN	ir	n_2 min ⁻¹	P_N kW	T_N kNm	Fa_2 Fr_1 kN	ir	n_2 min ⁻¹	P_N kW	T_N kNm	Fa_2 Fr_1 kN
1450	19.7	74	82	9.9	207 5.8	20.1	72	110	13.6	249 6.8	19.1	76	172	20.1	338 9.3
1000		51	58	10.1			50	78	13.9			52	121	20.5	
500		25	30	10.5			25	40	14.4			26	63	21.3	
1450	22.3	65	73	10.0	219 5.8	22.7	64	99	13.7	256 6.8	21.5	67	154	20.3	349 9.3
1000		45	52	10.2			44	69	14.0			46	108	20.7	
500		22	27	10.5			22	36	14.4			23	56	21.4	
1450	23.7	61	69	10.0	219 6.1	24.2	60	93	13.7	264 7.0	24.5	59	136	20.4	361 9.5
1000		42	48	10.2			41	65	14.0			41	96	20.8	
500		21	25	10.6			21	34	14.5			20	49	21.5	
1450	27.1	54	61	10.1	226 6.1	27.6	53	82	13.8	273 7.0	28.0	52	119	20.5	373 9.5
1000		37	43	10.3			36	58	14.1			36	84	20.9	
500		18.5	22	10.6			18.1	30	14.6			18	44	21.7	
1450	29.0	50	57	10.1	233 6.3	29.5	49	77	13.9	273 7.2	30.1	48	112	20.6	387 9.7
1000		34	40	10.3			34	54	14.1			33	78	21.0	
500		17.2	21	10.7			16.9	28	14.6			17.8	41	21.7	
1450	33.5	43	50	10.2	250 6.3	34.1	42	67	14.0	283 7.2	35.0	41	97	20.8	401 9.7
1000		30	35	10.4			29	47	14.2			29	68	21.2	
500		14.9	18.1	10.8			14.6	24	14.7			14.3	35	21.9	
1450	39.3	37	43	10.3	260 6.6	40.0	36	57	14.1	305 7.5	41.4	35	82	20.9	417 10.0
1000		25	30	10.5			25	40	14.4			24	58	21.3	
500		12.7	15.4	10.8			12.5	21	14.8			12.1	30	21.9	
1450	46.8	31	36	10.4	270 6.6	43.6	33	53	14.2	305 7.5	45.3	32	76	21.0	432 10.0
1000		21	25	10.6			23	37	14.4			22	53	21.4	
500		10.7	13.0	10.8			11.5	19.1	14.8			11.0	27	21.9	
1450	50.5	29	34	10.4	278 6.6	51.4	28	45	14.3	325 7.5	52.7	28	66	21.2	459 10.0
1000		19.8	24	10.6			19.5	32	14.5			19.0	46	21.6	
500		9.9	12.0	10.8			9.7	16.2	14.8			9.5	23	21.9	
1450	59.2	25	29	10.5	298 6.6	60.2	24	39	14.4	336 7.5	57.2	25	61	21.3	477 10.0
1000		16.9	20	10.7			16.6	27	14.7			17.5	43	21.7	
500		8.5	10.3	10.8			8.3	13.8	14.8			8.7	22	21.9	
1450	64.4	23	27	10.5	311 6.9	65.6	22	36	14.4	349 7.7	62.3	23	56	21.4	480 10.4
1000		15.5	18.7	10.7			15.3	25	14.7			16.1	39	21.8	
500		7.8	9.4	10.8			7.6	12.7	14.8			8.0	19.8	21.9	
1450	70.5	21	25	10.6	311 6.9	71.7	20	33	14.5	364 7.7	68.1	21	51	21.5	485 10.4
1000		14.2	17.2	10.8			13.9	23	14.8			14.7	36	21.9	
500		7.1	8.6	10.8			7.0	11.6	14.8			7.3	18.1	21.9	
1450	77.6	18.7	22	10.6	321 6.9	84.4	17.2	28	14.6	375 7.7	80.2	18.1	44	21.7	513 10.4
1000		12.9	15.7	10.8			11.8	19.7	14.8			12.5	31	21.9	
500		6.4	7.8	10.8			5.9	9.9	14.8			6.2	15.4	21.9	
1450	90.3	16.0	19.3	10.7	332 6.9	92.0	15.8	26	14.7	389 7.7	87.3	16.6	41	21.7	513 10.4
1000		11.1	13.4	10.8			10.9	18.1	14.8			11.5	28	21.9	
500		5.5	6.7	10.8			5.4	9.1	14.8			5.7	14.1	21.9	
1450	98.9	14.7	17.8	10.8	339 6.9	101	14.4	24	14.8	396 7.7	95.6	15.2	37	21.8	531 10.4
1000		10.1	12.3	10.8			9.9	16.5	14.8			10.5	26	21.9	
500		5.1	6.1	10.8			5.0	8.3	14.8			5.2	12.9	21.9	
1450	109	13.3	16.1	10.8	339 6.9	111	13.1	22	14.8	414 7.7	105	13.8	34	21.9	542 10.4
1000		9.2	11.2	10.8			9.0	15.0	14.8			9.5	23	21.9	
500		4.6	5.6	10.8			4.5	7.5	14.8			4.8	11.7	21.9	
1450	121	12.0	14.6	10.8	362 6.9	123	11.8	19.7	14.8	424 7.7	117	12.4	31	21.9	566 10.4
1000		8.3	10.1	10.8			8.2	13.6	14.8			8.6	21	21.9	
500		4.1	5.0	10.8			4.1	6.8	14.8			4.3	10.6	21.9	
Potenze termiche - Thermal power - Thermische Grenzleistung (senza raffreddamento / Without cooling / ohne Kühlung)															
52						65					82				



RX 800 754 814						1033 816					1441 818					1933 820										
n_1 min ⁻¹	ir	n_2 min ⁻¹	P _N kW	T _N kNm	Fa ₂ Fr ₁ kN	ir	n_2 min ⁻¹	P _N kW	T _N kNm	Fa ₂ Fr ₁ kN	ir	n_2 min ⁻¹	P _N kW	T _N kNm	Fa ₂ Fr ₁ kN	ir	n_2 min ⁻¹	P _N kW	T _N kNm	Fa ₂ Fr ₁ kN						
1450	19.4	75	232	27.5	395	19.4	75	331	39.4	439	19.4	745	490	58.1	531	19.7	74	661	79.9	707						
1000		52	163	28.0	11.5		52	233	40.2			14.7	52	338			58.2	51	464		81.4	19.3	51	464	81.4	
500		26	84	29.0	26		121	41.6	26			169	58.2	26			169	58.2	25		240	84.2	25	240	84.2	
1450	21.9	66	206	27.7	408	21.9	66	296	39.7	453	21.8	67	438	58.5	552	22.3	65	588	80.3	730						
1000		46	145	28.2			11.5	46	208			40.4	14.7	46			308	59.6	45		414	81.9	19.3	45	414	81.9
500		23	75	29.2			23	107	41.8			23	156	60.4			23	156	60.4		22	214	84.7	22	214	84.7
1450	24.9	58	183	27.9	421	24.9	58	262	39.9	468	24.6	59	390	58.8	570	23.7	61	554	80.6	730						
1000		40	128	28.4			11.7	40	184			40.7	14.8	41			274	60.0	42		389	82.1	19.8	42	389	82.1
500		20	66	29.4			20	95	42.1			20	142	62.1			20	142	62.1		21	201	85.0	21	201	85.0
1450	28.5	51	160	28.0	435	26.6	55	246	40.0	484	28.0	52	345	59.2	609	27.1	54	489	81.1	754						
1000		35	113	28.6			11.7	38	173			40.8	14.8	36			242	60.3	37		344	82.7	19.8	37	344	82.7
500		17.6	58	29.6			17.6	18.8	89			42.2	17.9	125			62.5	17.9	125		62.5	18.5	178	85.6	18.5	178
1450	30.6	47	150	28.1	440	30.6	47	215	40.3	502	30.0	48	323	59.4	631	31.1	47	428	81.7	808						
1000		33	106	28.7			12.0	33	151			41.1	15.1	33			227	60.5	32		300	83.2	20.2	32	300	83.2
500		16	55	29.7			16	78	42.5			16.7	118	62.7			16.7	118	62.7		16.1	156	86.2	16.1	156	86.2
1450	32.9	44	140	28.3	452	32.9	44	201	40.5	510	34.6	42	282	59.9	654	36.3	40	370	82.3	837						
1000		30	98	28.8			12.0	30	141			41.2	15.1	29			198	61.0	28		260	83.9	20.2	28	260	83.9
500		15	51	29.8			15	73	42.7			14.4	102	63.1			14.4	102	63.1		13.8	135	86.8	13.8	135	86.8
1450	38.6	38	120	28.5	486	38.5	38	173	40.8	520	37.4	39	262	60.1	660	39.3	37	343	82.7	870						
1000		26	84	29.0			12.2	26	121			41.6	15.5	27			184	61.2	25		241	84.2	20.7	25	241	84.2
500		13.0	44	29.9			13.0	62	42.8			13.4	95	63.2			13.4	95	63.2		12.7	124	86.8	12.7	124	86.8
1450	46.0	32	102	28.7	519	45.9	32	146	41.2	560	44.1	33	224	60.6	680	46.8	31	290	83.4	901						
1000		22	72	29.3			12.2	22	103			41.9	15.5	23			157	61.7	21		204	85.0	20.7	21	204	85.0
500		10.9	37	29.9			10.9	52	42.8			11.3	81	63.2			11.3	81	63.2		10.7	104	86.8	10.7	104	86.8
1450	49.6	29	95	28.8	519	49.5	29	136	41.3	570	52.1	28	191	61.1	725	54.5	27	251	84.0	959						
1000		20	67	29.4			12.2	20	96			42.1	15.5	19			134	62.2	18.3		177	85.6	20.7	18.3	177	85.6
500		10.1	34	29.9			10.1	49	42.8			9.6	68	63.2			9.6	68	63.2		9.2	89	86.8	9.2	89	86.8
1450	58.1	25	82	29.1	556	58.0	25	117	41.6	596	56.3	26	178	61.3	725	59.2	25	233	84.4	995						
1000		17.2	57	29.6			12.2	17	82			42.4	15.5	17.8			125	62.5	16.9		164	86.0	20.7	16.9	164	86.0
500		8.6	29	29.9			8.6	42	42.8			8.9	63	63.2			8.9	63	63.2		8.5	83	86.8	8.5	83	86.8
1450	63.3	23	75	29.2	560	63.1	23	108	41.8	610	66.3	22	152	61.8	811	64.4	23	214	84.7	1000						
1000		15.8	53	29.7			12.4	15.8	76			42.6	15.7	15.1			107	63.0	15.5		151	86.3	21.6	15.5	151	86.3
500		7.9	27	29.9			7.9	38	42.8			7.5	54	63.2			7.5	54	63.2		7.8	76	86.8	7.8	76	86.8
1450	69.2	21	69	29.3	565	69.1	21	99	42.0	618	72.5	20	140	62.1	837	70.5	21	197	85.1	1038						
1000		14.4	49	29.9			12.4	14.5	70			42.8	15.7	13.8			98	63.2	14.2		138	86.7	21.6	14.2	138	86.7
500		7.2	24	29.9			7.2	35	42.8			6.9	49	63.2			6.9	49	63.2		7.1	69	86.8	7.1	69	86.8
1450	81.5	17.8	59	29.6	598	81.3	17.8	85	42.3	660	78.9	18.4	129	62.4	837	83.0	17.5	169	85.8	1070						
1000		12.3	41	29.9			12.4	12.3	59			42.8	15.7	12.7			90	63.2	12.1		118	86.8	21.6	12.1	118	86.8
500		6.1	21	29.9			6.1	30	42.8			6.3	45	63.2			6.3	45	63.2		6.0	59	86.8	6.0	59	86.8
1450	88.7	16.3	55	29.7	600	88.5	16.4	78	42.5	665	93.0	15.6	110	62.9	884	90.3	16.0	156	86.2	1110						
1000		11.3	38	29.9			12.4	11.3	54			42.8	15.7	10.8			76	63.2	11.1		108	86.8	21.6	11.1	108	86.8
500		5.6	19.0	29.9			5.6	27	42.8			5.4	38	63.2			5.4	38	63.2		5.5	54	86.8	5.5	54	86.8
1450	97.1	14.9	50	29.8	620	96.8	15.0	72	42.7	689	102	14.3	101	63.2	992	98.9	14.7	143	86.6	1131						
1000		10.3	35	29.9			12.4	10.3	50			42.8	15.7	9.8			70	63.2	10.1		99	86.8	21.6	10.1	99	86.8
500		5.2	17.3	29.9			5.2	25	42.8			4.9	35	63.2			4.9	35	63.2		5.1	49	86.8	5.1	49	86.8
1450	107	13.6	46	29.9	632	107	13.6	66	42.8	730	112	13.0	92	63.2	992	109	13.3	130	86.8	1181						
1000		9.4	31	29.9			12.4	9.4	45			42.8	15.7	8.9			64	63.2	9.2		90	86.8	21.6	9.2	90	86.8
500		4.7	15.7	29.9			4.7	23	42.8			4.5	32	63.2			4.5	32	63.2		4.6	45	86.8	4.6	45	86.8
1450	118	12.2	41	29.9	660	118	12.3	59	42.8	734	124	11.7	83	63.2	945	121	12.0	117	86.8	1210						
1000		8.4	28	29.9			12.4	8.5	41			42.8	15.7	8.1			57	63.2	8.3		81	86.8	21.6	8.3	81	86.8
500		4.2	14.2	29.9			4.2	20.4	42.8			4.0	29	63.2			4.0	29	63.2		4.1	40	86.8	4.1	40	86.8

Potenze termiche - Thermal power - Thermische Grenzleistung
(senza raffreddamento / Without cooling / ohne Kühlung)

102

127

165

205



712 - 720

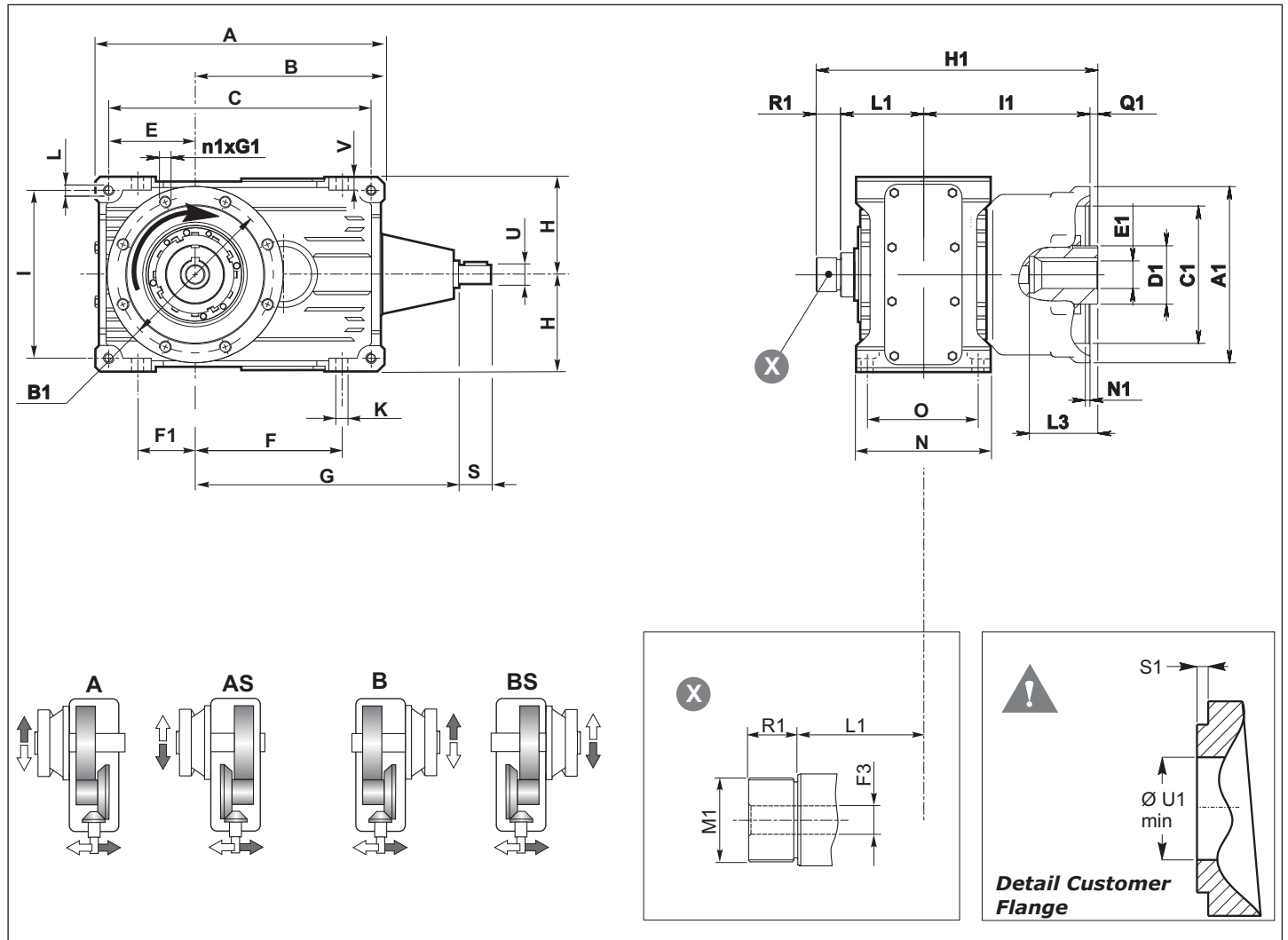

Dimensioni generali / Dimensions / Allgemeine Abmessungen													
	A	B	C	E	F	F1	H h11	I	K	L	N h11	O	V
712	326	214	296	97	166	64	112	194	13	M12	150	125	15
716	407	267	371	122	209	82	140	244	15	M14	175	145	16
720	522.5	342.5	482.5	160	272.5	110	180	320	17	M16	215	180	17

Riduttore/ Gear unit / Getriebe																						
	A1	B1	C1 H7	D1	E1 H7	E1 max	F3	G1	H1	I1	L1	M1	M3	N1	n1	L3	Q1	R1	S1	U1	thrust max load	Kg
712	180	160	140	55	28	38	18	M12x25	288	170	85	M35x1.5	—	5	8	70	8	25	3	90	29412	45
716	200	170	150	55	32	38	19	M12x25	319	180	106	M35x1.5	—	5	8	90	8	25	3	90	29412	76
720	230	205	180	70	32	50	24	M12x25	380	218.5	123.5	M50x1.5	—	5	8	90	8	30	3	110	29415	177

712 - 720

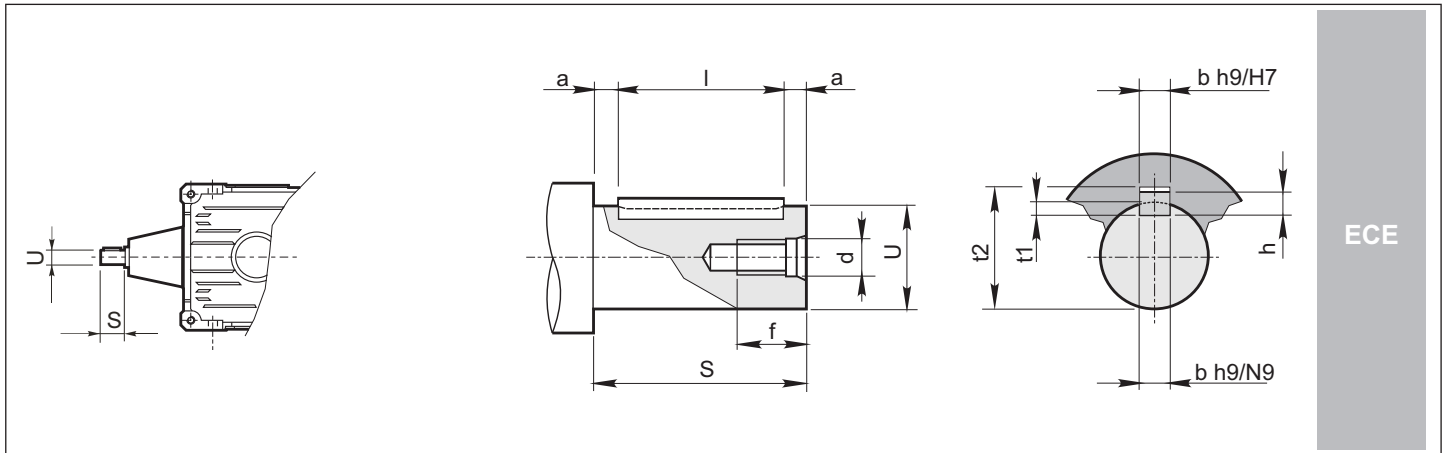

RX01				Foro fil. testa Tapped hole Gewindebohrung Kopf		Cava Keyway Nut			Estremità d'albero Shaft end Wellenende			Linguetta Key Federkeil
Size	U	S	G	d	f	b	t1	t2	U	S a11	a	bxhxl
712	24 j6	50	260	M8	20	8	4	27.3	24 j6	50	5	8X7X40
716	28 j6	60	317	M8	20	8	4	31.3	28 j6	60	5	8X7X50
720	38 k6	80	400	M10	27	10	5	41.3	38 k6	80	5	10X8X70



	IEC															
	63	71	80		90		100		112		132		160		180	200
	B5	B5	B5	B14	B5	B14	B5	B14	B5	B14	B5	B14	B5	B14	B5	B5
D H7	11	14	19	19	24	24	28	28	28	28	38	38	42	48	55	
P	140	160	200	120	200	140	250	160	250	160	300	200	350	350	400	
MN	115	130	165	100	165	115	215	130	215	130	265	165	300	300	350	
N G6	95	110	130	80	130	95	180	110	180	110	230	130	250	250	300	
K	M8	M8	M10	M6	M10	M8	M12	M8	M12	M8	M12	M10	M16	M16	M16	
SP2/SP3/SP4/SP5	A richiesta / On request / Auf Anfrage															

RX01	Size	Type	G	IEC														
				63	71	80	90	100	112	132	160	180	200					
712	PAM... PAM..G - R	G2	365	—	365	—	375	—	375	—	395	—						
			311	—	311	—	311	—	311	—	311	311						
716	PAM... PAM..G - R	G2					442	—	442	—	—	—	—	—	—			
							442	—	442	—	396*	—	405*	405*				
720	PAM... PAM..G - R	G2	362	—	362	—	362	—	362	—	362	362						
											460*	—	469*	469*	474*			
			411		411		411	—	411	—	411	411						

* Solo PAM...G - forniti con giunto tipo Rotex.

* Only PAM...G - come with Rotex coupling.

* nur PAM...G - Werden sie mit Kupplung Typ Rotex geliefert.

712 - 720

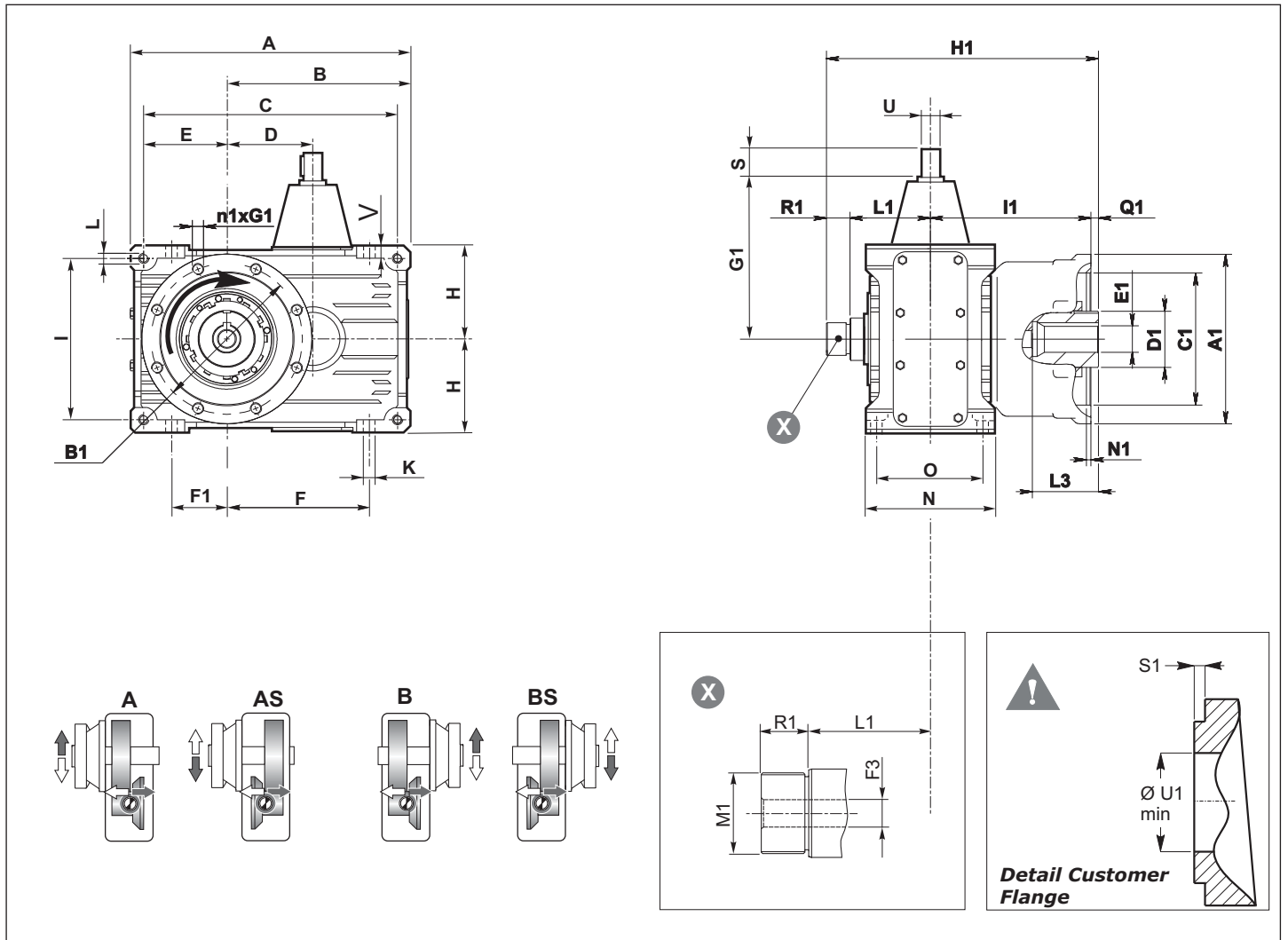

Dimensioni generali / Dimensions / Allgemeine Abmessungen														
	A	B	C	D	E	F	F1	H h _{h11}	I	K	L	N h _{h11}	O	V
712	326	214	296	100	97	166	64	112	194	13	M12	150	125	15
716	407	267	371	127	122	209	82	140	244	15	M14	175	145	16
720	522.5	342.5	482.5	160	160	272.5	110	180	320	17	M16	215	180	17

Riduttore/ Gear unit / Getriebe																						
	A1	B1	C1 H7	D1	E1 H7	E1 max	F3	G1	H1	I1	L1	M1	M3	N1	n1	L3	Q1	R1	S1	U1	thrust max load	Kg
712	180	160	140	55	28	38	18	M12x25	288	170	85	M35x1.5	—	5	8	70	8	25	3	90	29412	45
716	200	170	150	55	32	38	19	M12x25	319	180	106	M35x1.5	—	5	8	90	8	25	3	90	29412	76
720	230	205	180	70	32	50	24	M12x25	380	218.5	123.5	M50x1.5	—	5	8	90	8	30	3	110	29415	177

712 - 720

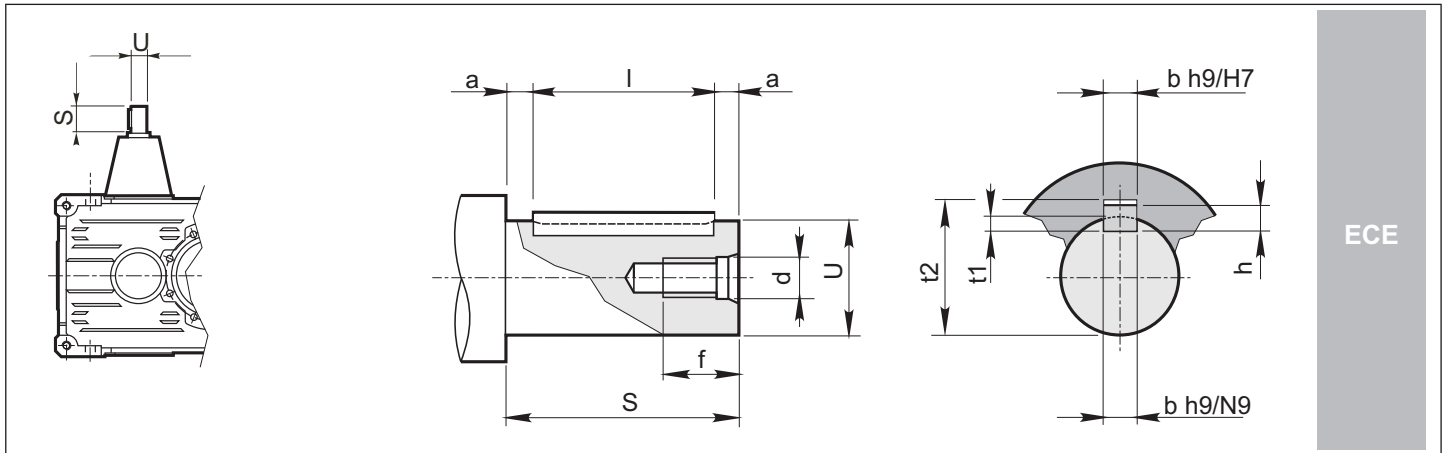

ECE

RXV 1				Foro fil. testa Tapped hole Gewindebohrung Kopf		Cava Keyway Nut			Estremità d'albero Shaft end Wellenende			Linguetta Key Federkeil
Size	U	S	G1	d	f	b	t1	t2	U	S a11	a	bxhxl
712	24 j6	50	160	M8	20	8	4	27.3	24 j6	50	5	8X7X40
716	28 j6	60	190	M8	20	8	4	31.3	28 j6	60	5	8X7X50
720	38 k6	80	240	M10	27	10	5	41.3	38 k6	80	5	10X8X70

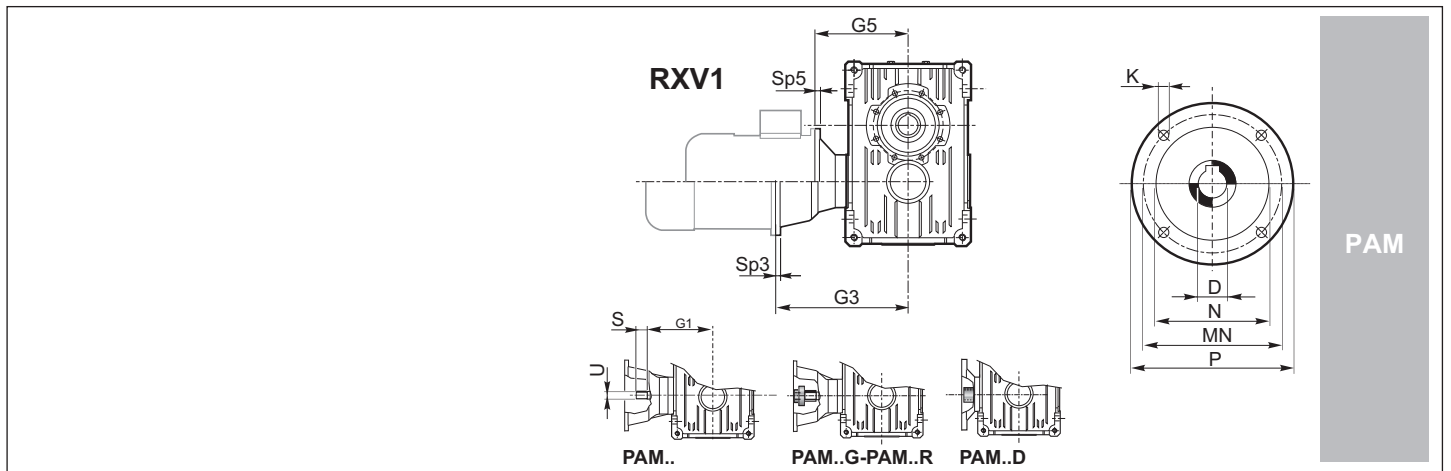

PAM

	IEC														
	63	71	80		90		100		112		132		160	180	200
D H7	B5	B5	B5	B14	B5	B14	B5	B14	B5	B14	B5	B14	B5	B5	B5
P	11	14	19	19	24	24	28	28	28	28	38	38	42	48	55
MN	140	160	200	120	200	140	250	160	250	160	300	200	350	350	400
N G6	115	130	165	100	165	115	215	130	215	130	265	165	300	300	350
N G6	95	110	130	80	130	95	180	110	180	110	230	130	250	250	300
K	M8	M8	M10	M6	M10	M8	M12	M8	M12	M8	M12	M10	M16	M16	M16
SP2/SP3/SP4/SP5	A richiesta / On request / Auf Anfrage														

RXV1	Size	Type	G	IEC														
				63	71	80		90		100		112		132		160	180	200
712	PAM... PAM..G - R PAM..D	G3 G5 G5	G3	265	—	265	—	275	—	275	—	295	—	—	—	—		
				211	—	211	—	211	—	211	211	—	—	—	—	—		
				—	—	—	—	316	—	316	—	—	—	—	—	—	—	
716	PAM... PAM..G - R PAM..D	G3 G3 G5	G3	—	—	—	—	316	—	316	—	269*	—	278*	278*	—		
				239	—	239	—	239	—	239	—	239	239	—	—	—		
				—	—	—	—	—	—	—	—	—	—	—	—	—	—	
720	PAM... PAM..G - R PAM..D	G3 G3 G5	G3	—	—	—	—	—	—	—	—	300*	—	309*	309*	314*		
				251	—	251	—	251	—	251	—	251	251	—	—	—		
				—	—	—	—	—	—	—	—	—	—	—	—	—	—	

*Solo PAM...G - forniti con giunto tipo Rotex.

* Only PAM...G - come with Rotex coupling.

* nur PAM...G - Werden sie mit Kupplung Typ Rotex geliefert.

802 - 820

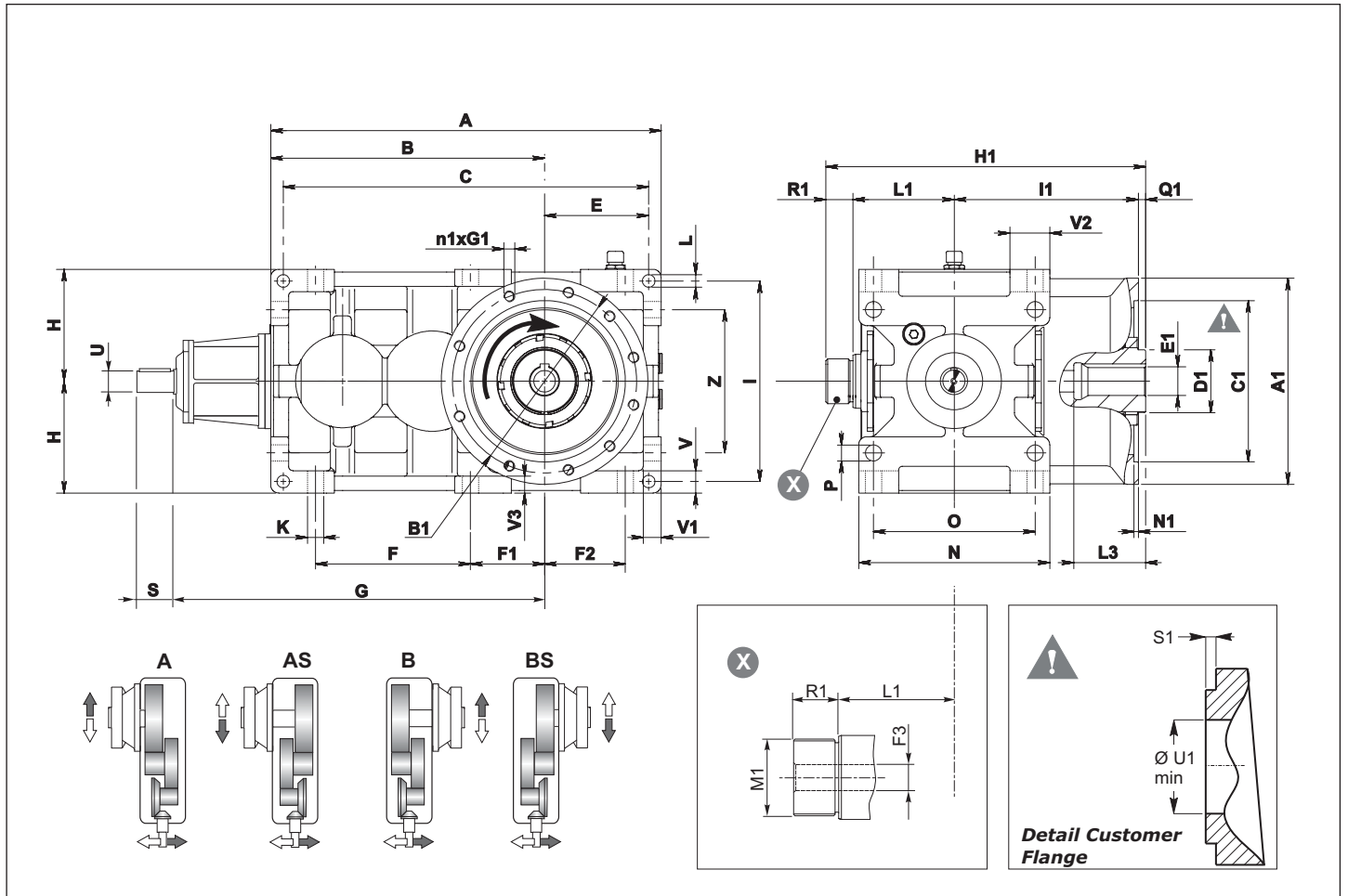

Dimensioni generali / Dimensions / Allgemeine Abmessungen																			
	A	B	C	E	F	F1	F2	H _{h11}	I	K	L	N _{h11}	O	P	V	V1	V2	V3	Z
802	435	305	407	116	172.5	82.5	90	125	224	18	14	213	180	18	25	20	44.5	19	160
804	492	342	460	134	195	91	104	140	250	20	16	237	200	20	28	22.5	49	23	180
806	555	385	521	153	219.5	102.5	117	160	280	22	18	269	225	22	32	25	56.5	25	200
808	622	432	584	171	246	116	130	180	320	25	20	297	250	25	36	28	59.5	28	224
810	695	485	655	190	275	130	145	200	360	27	22	335	280	27	40	32	67.5	32	250
812	785	545	740	217.5	307.5	147.5	160	225	400	30	24	379	315	30	45	36	78.5	36	280
814	875	610	825	240	345	165	180	250	450	33	27	427	355	33	50	40	89	40	320
816	985	685	929	272	388	185	203	280	500	36	30	479	400	36	56	45	96.5	45	360
818	1110	770	1046	308	437.5	207.5	230	315	560	39	35	541	450	39	63	50	114.5	48	400
820	1245	865	1173	344	492.5	232.5	260	355	638	42	39	599	500	42	70	56	124	56	450

Riduttore/ Gear unit / Getriebe																						
	A1	B1	C1 H7	D1	E1 H7	E1 max	F3	G1	H1	I1	L1	M1	M3	N1	n1	L3	Q1	R1	S1	U1	thrust max load	Kg
802	230	205	180	70	32	50	24	M12x25	356	205	113	M50x1.5	—	5	8	80	8	30	3	110	29415	111
804	260	230	200	80	38	60	27	M12x25	392	230	124	M50x1.5	—	5	8	80	8	30	3	120	29417	155
806	300	260	230	95	42	70	29	M16x35	457	260	140	M65x2	—	6	8	80	17	40	4	140	29420	210
808	350	300	260	110	48	80	34	M20x40	504	290	157	M65x2	—	6	8	110	17	40	4	165	29424	289
810	380	330	290	120	60	90	42	M20x40	563	320	175	M85x2	—	6	8	110	18	50	4	175	29428	396
812	400	350	310	130	70	100	55	M20x40	611	355	188	M85x2	—	6	12	140	18	50	4	205	29430	549
814	450	400	365	160	80	120	55	M24x50	687	405	212	M85x2	—	8	12	140	20	50	6	235	29434	754
816	500	450	400	170	90	130	60	M24x50	755	445	240	M90x2	—	8	12	160	20	50	6	245	29436	1033
818	600	500	450	190	100	140	60	M24x50	830	490	270	M90x2	—	8	12	180	20	50	6	265	29440	1441
820	680	600	520	200	110	150	80	M30x60	936	560	302	M120x2	—	10	12	200	24	50	8	320	29452	1933

802 - 820

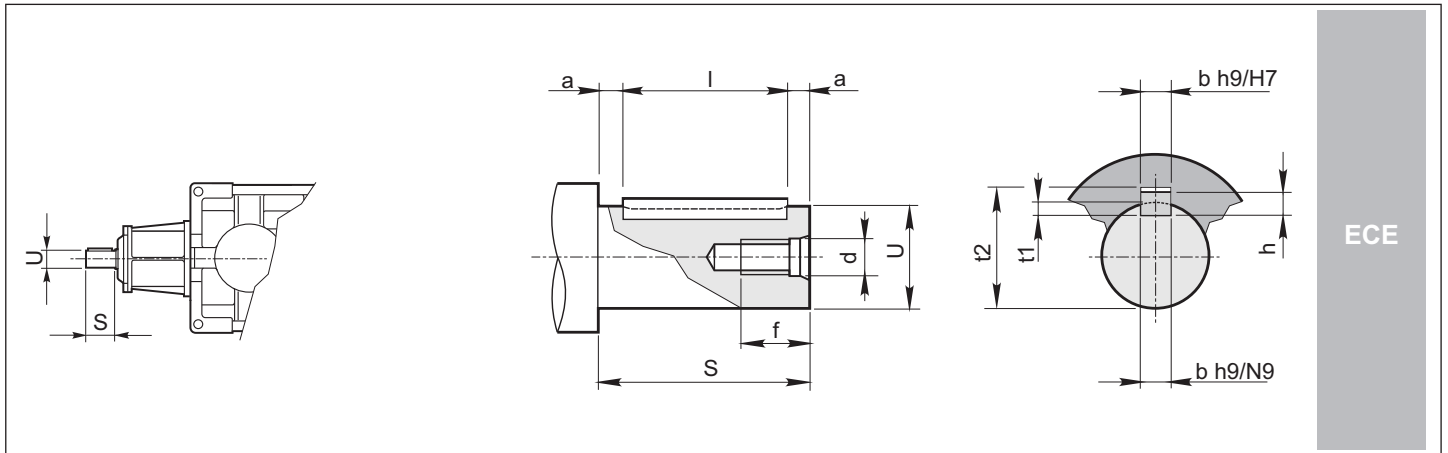

RXO 2 RXV 2				Foro fil. testa Tapped hole Gewindebohrung Kopf		Cava Keyway Nut			Estremità d'albero Shaft end Wellenend			Linguetta Key Federkeil
Size	U	S	G	d	f	b	t ₁	t ₂	U	S a11	a	bxhxl
802	22 j6	40	405	M6	18	6	3.5	24.8	22 j6	40	2.5	6x6x35
804	24 j6	45	452	M8	22	8	4	27.3	24 j6	45	2.5	8x7x40
806	28 j6	50	510	M8	22	8	4	31.3	28 j6	50	2.5	8x7x45
808	32 k6	56	570	M8	22	10	5	35.3	32 k6	56	3	10x8x50
810	35 k6	63	640	M10	27	10	5	38.3	35 k6	63	4	10x8x55
812	40 k6	70	720	M10	27	12	5	43.3	40 k6	70	5	12x8x60
814	45 k6	80	805	M10	27	14	5.5	48.8	45 k6	80	5	14x9x70
816	50 m6	90	905	M12	35	14	5.5	53.8	50 m6	90	5	14x9x80
818	55 m6	100	1020	M12	35	16	6	59.3	55 m6	100	5	16x10x90
820	60 m6	112	1140	M12	35	18	7	64.4	60 m6	112	6	18x11x100

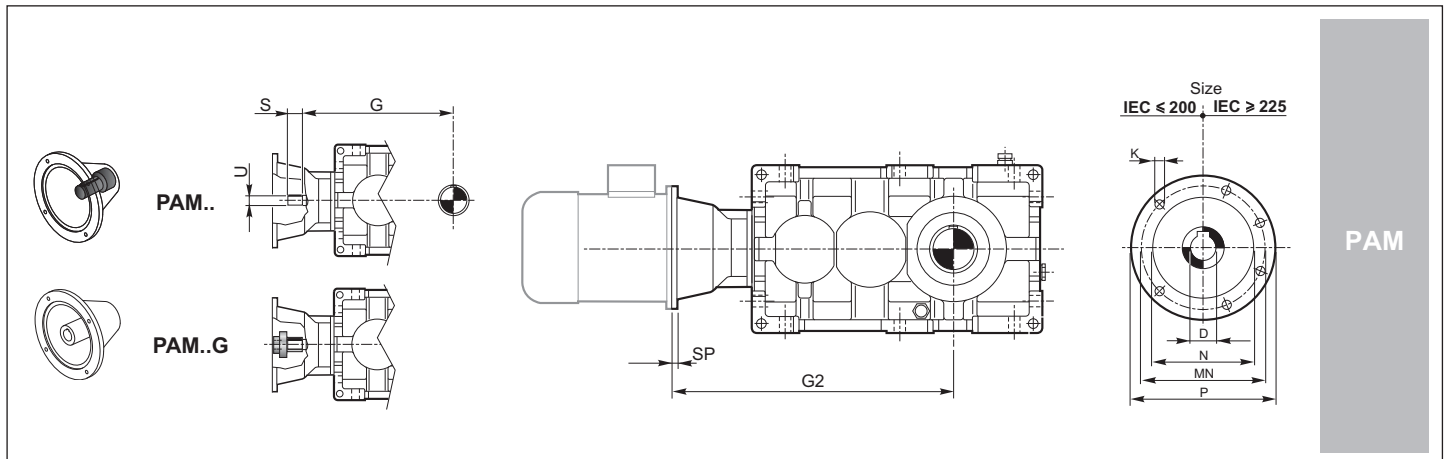

		IEC													
		71	80	90	100	112	132	160	180	200	225	250	280	315	355
D H7		14	19	24	28	28	38	42	48	55	60	65	75	80	100
P		160	200	200	250	250	300	350	350	400	450	550	550	660	800
MN		130	165	165	215	215	265	300	300	350	400	500	500	600	740
N G6		110	130	130	180	180	230	250	250	300	350	450	450	550	680
K		M8	M10	M10	M12	M12	M12	M16	M16	M16	M16	M16	M16	M20	M20
SP		12	12	12	14	14	16	18	18	20	20	20	20	24	30
G2	802			499	509	509	529	559	559	559					
	804				561	561	581	611	611	611	641				
	806				624	624	644	674	674	674	704				
	808						710	740	740	740	770	770			
	810						787	817	817	817	847	847	847	877	
	812						874	904	904	904	934	934	934	964	
	814							999	999	999	1029	1029	1029	1059	
	816							1109	1109	1109	1139	1139	1139	1169	1209
	818									1234	1264	1264	1264	1294	1334
	820										1396	1396	1396	1426	1466

802 - 820

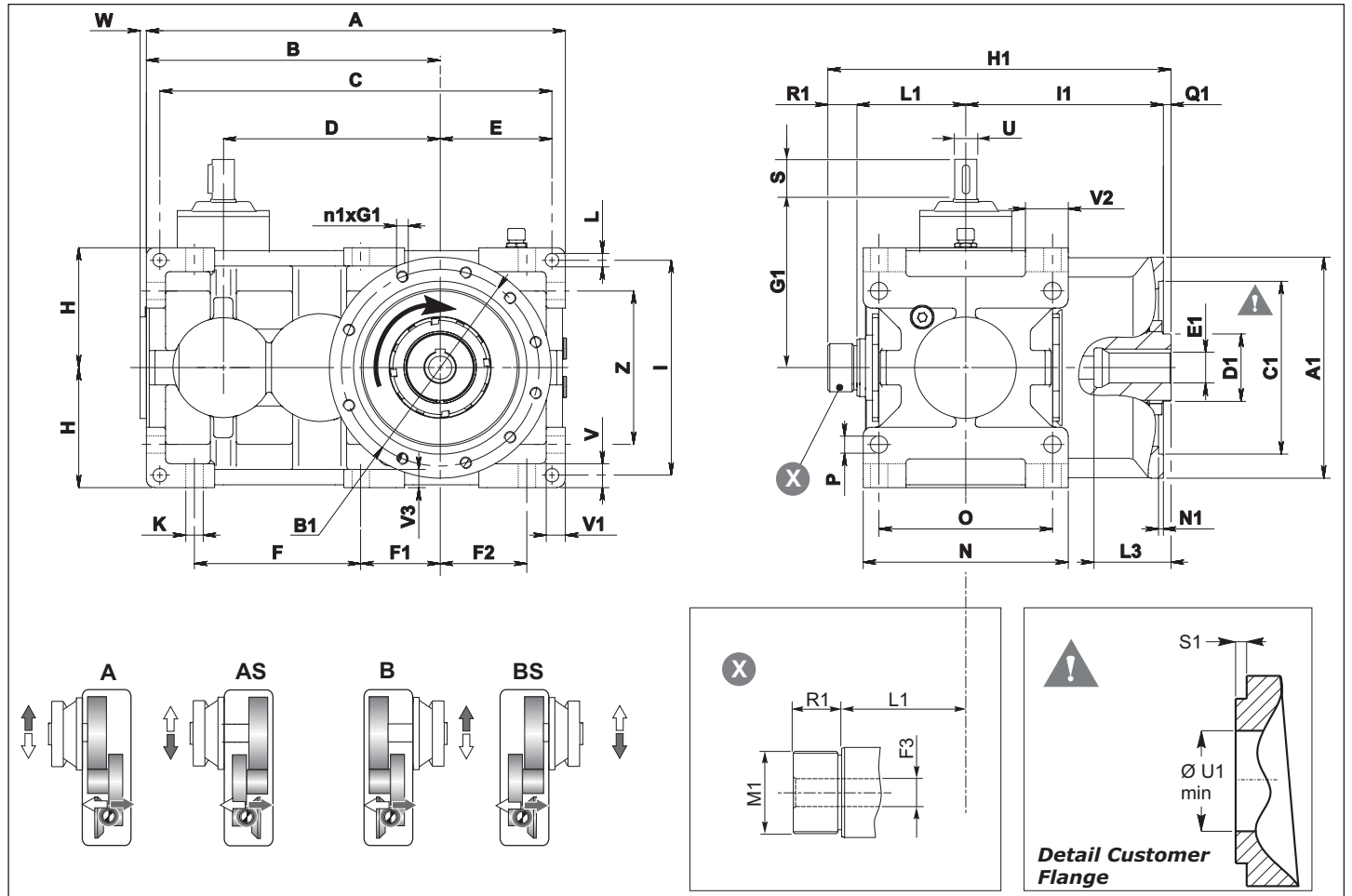

Dimensioni generali / Dimensions / Allgemeine Abmessungen																					
	A	B	C	D	E	F	F1	F2	H _{h11}	I	K	L	N _{h11}	O	P	V	V1	V2	V3	W*	Z
802	435	305	407	225	116	172.5	82.5	90	125	224	18	14	213	180	18	25	20	44.5	19	14	160
804	492	342	460	252	134	195	91	104	140	250	20	16	237	200	20	28	22.5	49	23	15	180
806	555	385	521	285	153	219.5	102.5	117	160	280	22	18	269	225	22	32	25	56.5	25	17	200
808	622	432	584	320	171	246	116	130	180	320	25	20	297	250	25	36	28	59.5	28	18	224
810	695	485	655	360	190	275	130	145	200	360	27	22	335	280	27	40	32	67.5	32	20	250
812	785	545	740	405	217.5	307.5	147.5	160	225	400	30	24	379	315	30	45	36	78.5	36	21	280
814	875	610	825	450	240	345	165	180	250	450	33	27	427	355	33	50	40	89	40	24	320
816	985	685	929	505	272	388	185	203	280	500	36	30	479	400	36	56	45	96.5	45	28	360
818	1110	770	1046	570	308	437.5	207.5	230	315	560	39	35	541	450	39	63	50	114.5	48	29	400
820	1245	865	1173	640	344	492.5	232.5	260	355	638	42	39	599	500	42	70	56	124	56	30	450

Riduttore/ Gear unit / Getriebe																						
	A1	B1	C1 H7	D1	E1 H7	E1 max	F3	G1	H1	I1	L1	M1	M3	N1	n1	L3	Q1	R1	S1	U1	thrust max load	Kg
802	230	205	180	70	32	50	24	M12x25	356	205	113	M50x1.5	—	5	8	80	8	30	3	110	29415	111
804	260	230	200	80	38	60	27	M12x25	392	230	124	M50x1.5	—	5	8	80	8	30	3	120	29417	155
806	300	260	230	95	42	70	29	M16x35	457	260	140	M65x2	—	6	8	80	17	40	4	140	29420	210
808	350	300	260	110	48	80	34	M20x40	504	290	157	M65x2	—	6	8	110	17	40	4	165	29424	289
810	380	330	290	120	60	90	42	M20x40	563	320	175	M85x2	—	6	8	110	18	50	4	175	29428	396
812	400	350	310	130	70	100	55	M20x40	611	355	188	M85x2	—	6	12	140	18	50	4	205	29430	549
814	450	400	365	160	80	120	55	M24x50	687	405	212	M85x2	—	8	12	140	20	50	6	235	29434	754
816	500	450	400	170	90	130	60	M24x50	755	445	240	M90x2	—	8	12	160	20	50	6	245	29436	1033
818	600	500	450	190	100	140	60	M24x50	830	490	270	M90x2	—	8	12	180	20	50	6	265	29440	1441
820	680	600	520	200	110	150	80	M30x60	936	560	302	M120x2	—	10	12	200	24	50	8	320	29452	1933

* Non in posizione M4.

1.11 Dimensioni

1.11 Dimensions

1.11 Abmessungen

802 - 820

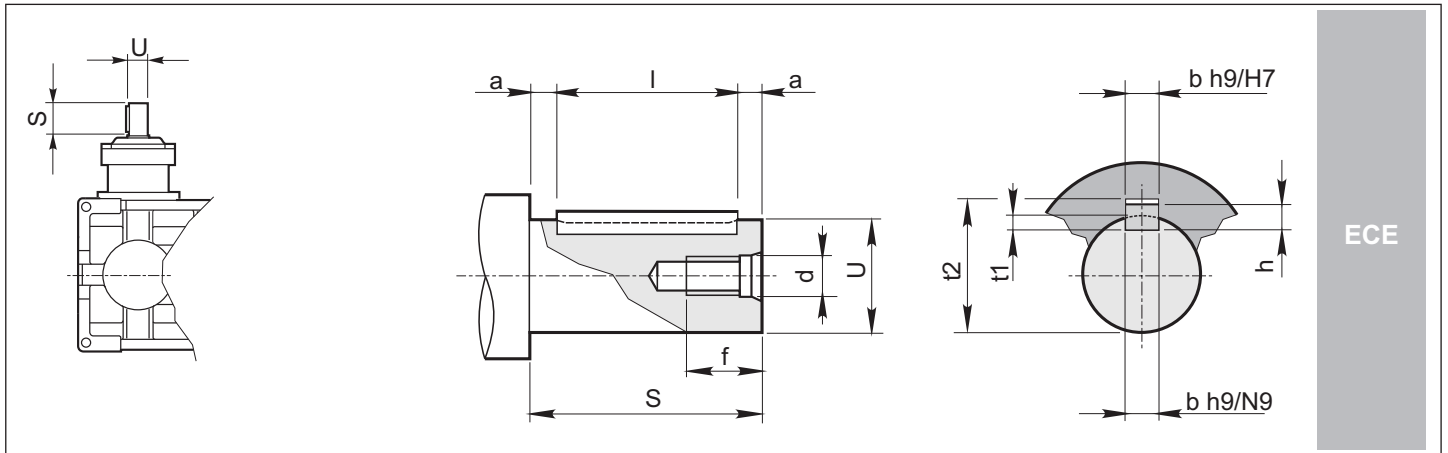

ECE

RXO 2 RXV 2				Foro fil. testa Tapped hole Gewindebohrung Kopf		Cava Keyway Nut			Estremità d'albero Shaft end Wellenend			Linguetta Key Federkeil
Size	U	S	G1	d	f	b	t ₁	t ₂	U	S a11	a	bxhxl
802	22 j6	40	180	M6	18	6	3.5	24.8	22 j6	40	2.5	6x6x35
804	24 j6	45	200	M8	22	8	4	27.3	24 j6	45	2.5	8x7x40
806	28 j6	50	225	M8	22	8	4	31.3	28 j6	50	2.5	8x7x45
808	32 k6	56	250	M8	22	10	5	35.3	32 k6	56	3	10x8x50
810	35 k6	63	280	M10	27	10	5	38.3	35 k6	63	4	10x8x55
812	40 k6	70	315	M10	27	12	5	43.3	40 k6	70	5	12x8x60
814	45 k6	80	355	M10	27	14	5.5	48.8	45 k6	80	5	14x9x70
816	50 m6	90	400	M12	35	14	5.5	53.8	50 m6	90	5	14x9x80
818	55 m6	100	450	M12	35	16	6	59.3	55 m6	100	5	16x10x90
820	60 m6	112	500	M12	35	18	7	64.4	60 m6	112	6	18x11x100

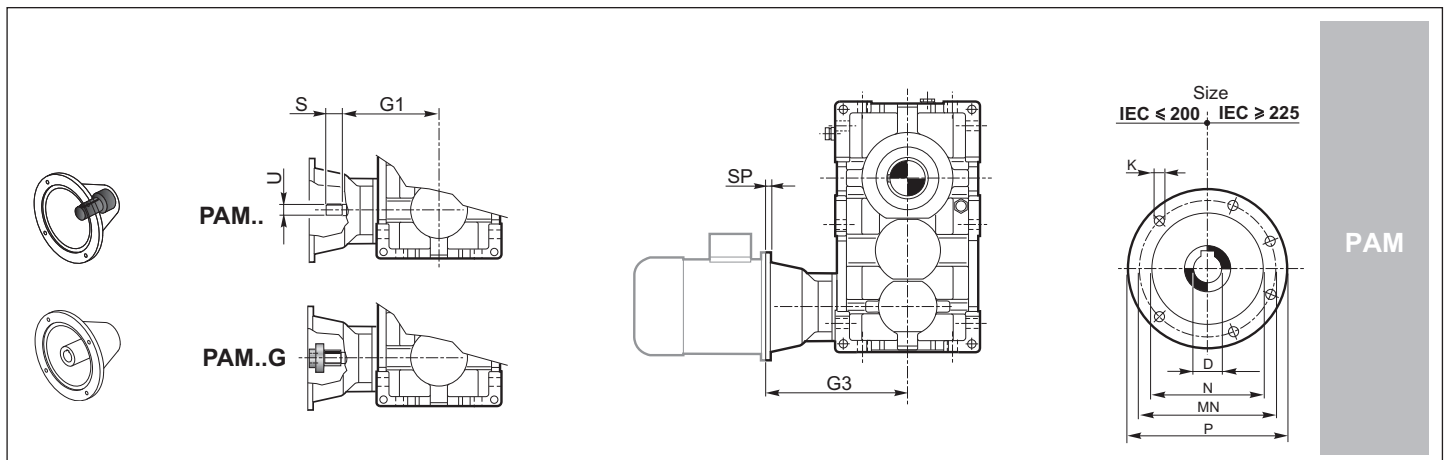

		IEC													
		71	80	90	100	112	132	160	180	200	225	250	280	315	355
D H7		14	19	24	28	28	38	42	48	55	60	65	75	80	100
P		160	200	200	250	250	300	350	350	400	450	550	550	660	800
MN		130	165	165	215	215	265	300	300	350	400	500	500	600	740
N G6		110	130	130	180	180	230	250	250	300	350	450	450	550	680
K		M8	M10	M10	M12	M12	M12	M16	M16	M16	M16	M16	M16	M20	M20
SP		12	12	12	14	14	16	18	18	20	20	20	20	24	30
G3	802			274	284	284	304	334	334	334					
	804				309	309	329	359	359	359	389				
	806				339	339	359	389	389	389	419				
	808						390	420	420	420	450	450	450		
	810						427	457	457	457	487	487	487	517	
	812						469	499	499	499	529	529	529	559	
	814							549	549	549	579	579	579	609	
	816							604	604	604	634	634	634	664	704
	818									664	694	694	694	724	764
820										756	756	756	786	826	