

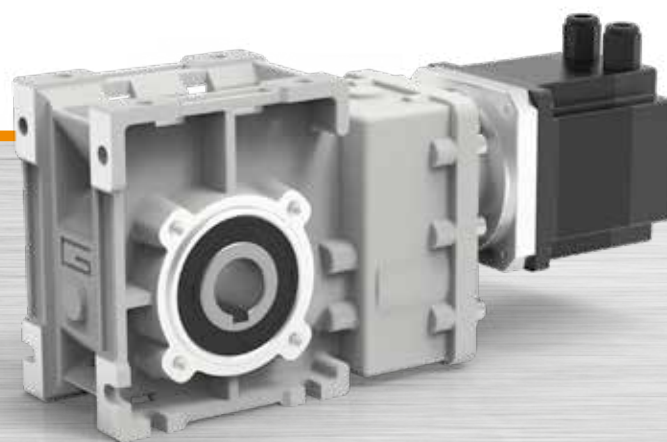

Motoriduttori brushless CC ad assi ortogonali
Brushless DC helical bevel gearmotors

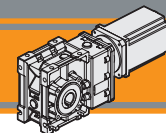



Indice	Index	Pag. Page
Caratteristiche tecniche	<i>Technical features</i>	C2
Designazione	<i>Classification</i>	C2
Simbologia	<i>Symbols</i>	C3
Lubrificazione e temperatura	<i>Lubrication and temperature</i>	C3
Carichi radiali	<i>Radial loads</i>	C3
CMB402 con motore brushless BLS043.240	<i>CMB402 with BLS043.240 brushless motor</i>	C4
CMB402 con motore brushless BL070.240 / BL070.480 / BL070.48B	<i>CMB402 with BL070.240 / BL070.480 / BL070.48B brushless motor</i>	C5
CMB402 con motore brushless BL140.480	<i>CMB402 with BL140.480 brushless motor</i>	C6
CMB502 con motore brushless BL070.240 / BL070.480 / BL070.48B	<i>CMB502 with BL070.240 / BL070.480 / BL070.48B brushless motor</i>	C7
CMB502 con motore brushless BL140.480	<i>CMB502 with BL140.480 brushless motor</i>	C8
CMB502 con motore brushless BL210.480 / BL210.48E	<i>CMB502 with BL210.480 / BL210.48E brushless motor</i>	C9
Dati tecnici	<i>Technical data</i>	C10
Dimensioni CMB con flange motore AS	<i>CMB dimensions with motor flanges AS</i>	C11
Flange uscita	<i>Output flange</i>	C12
Accessori	<i>Accessories</i>	C13

Questa sezione annulla e sostituisce ogni precedente edizione o revisione. Qualora questa sezione non Vi sia giunta in distribuzione controllata, l'aggiornamento dei dati ivi contenuto non è assicurato. **In tal caso la versione più aggiornata è disponibile sul nostro sito internet www.transtecno.com**

This section replaces any previous edition and revision. If you obtained this catalogue other than through controlled distribution channels, the most up to date content is not guaranteed. In this case the latest version is available on our web site www.transtecno.com

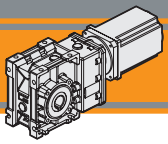

Caratteristiche tecniche

Technical features

Le caratteristiche principali dei motoriduttori brushless CC ad assi ortogonali della serie BLCMB sono:

The main features of BLCMB brushless DC helical bevel gearmotors range are:

- Alimentazione in bassa tensione 24/36/48 Vcc
- Motore BLDC con grado di protezione IP55
- Coppie motori disponibili da 0.43 Nm a 2.1 Nm
- Lubrificazione permanente con olio sintetico
- Carcassa in pressofusione di alluminio
- Ingranaggi cilindrici a denti elicoidali, induriti e rettificati
- Disponibili anche nella versione con solo riduttore, sia con flangia di entrata standard che con flangia e manicotto dedicati

- Low voltage power supply 24/36/48 Vdc
- BLDC motor in IP55 protection standard
- Motor torque ratings available from 0.43 Nm up to 2.1 Nm
- Permanent synthetic oil long life lubrication
- Die-cast aluminium housing
- Ground-hardened helical gears.
- Gearbox only version also available, with either standard input flange or customized flange and coupling

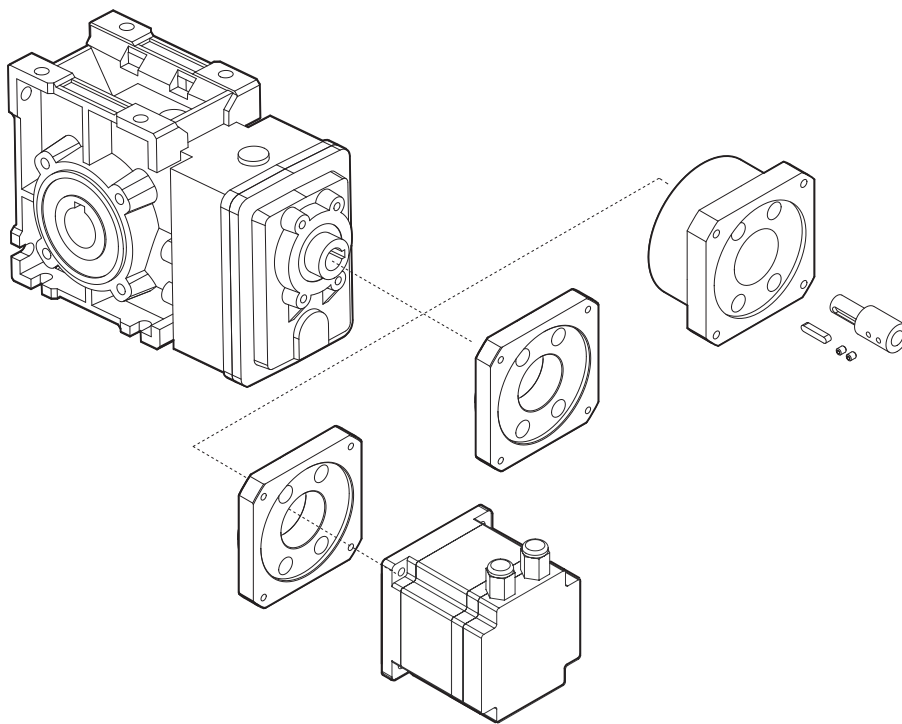

Designazione

Classification

RIDUTTORE / GEARBOX				
CMB	402	U	9.2	020
Tipo Type	Grandezza Size	Versione riduttore Gearbox version	Rapporto Ratio	Albero di uscita Output shaft
CMB	402 502	U FD FS FLD FLS FBD FBS	Vedere tabelle See tables	

MOTORE / MOTOR		
BL070.480	48V	BR
Tipo Type	Tensione Voltage	Freno Brake
BLS043.240 BL070.240 BL070.48B BL070.480 BL140.480 BL210.480 BL210.48E	24V-36V 24V 48V 48V 48V 48V 48V	24V 48V 

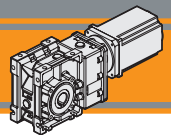

Simbologia

Symbols

Ns	n° stadi / No. stages	Mn ₂	[Nm]	Coppia nominale in uscita in funzione di Pn1 Nominal output torque referred to Pn1
ir	rapporto reale / real ratio	n _{1MAX}	[Rpm]	Velocità max entrata / Max input speed
M ₂	[Nm]	V	[V]	Tensione / Voltage
A ₂	[N]	n ₂	[Rpm]	Velocità in uscita / Output Speed
R ₂	[N]	IP		Grado di protezione / Enclosure protection
Pn ₁	[kW]	Kg		Peso / Weight
		sf		Fattore di servizio / Service Factor

BLCMB

Lubrificazione e temperaura

Lubrication and temperature

I motoriduttori BLCMB sono forniti completi di lubrificante sintetico (viscosità 320) e non necessitano di manutenzione.
Temperatura ambiente 0 ÷ 40 °C (in assenza di congelamento ed in assenza di condensa).
Per temperature diverse, contattare nostro UT.

Permanent synthetic oil long life lubrication (viscosity grade 320) on BLCMB gearmotors.
Ambient temperature 0 ÷ 40 °C (in the absence of freezing and condensation).
For temperature outside this range please contact our technical dept.

Carichi radiali

Radial loads

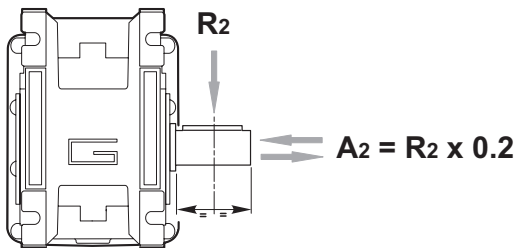

n ₂ [min ⁻¹]	R ₂ [N]	
	CMB 402	CMB 502
650	715	881
550	756	931
500	780	962
450	808	996
400	905	1116
300	996	1228
200	1141	1406
170	1204	1484
140	1414	1743
100	1582	1949
90	1638	2019
60	2047	2490
40	2524	3029
30	2778	3334
20	3180	3816
15	3500	4200
10	3500	4200

Quando il carico radiale risultante non è applicato sulla mezzeria dell'albero occorre calcolare quello effettivo con la seguente formula

When the resulting radial load is not applied on the centre line of the shaft it is necessary to calculate the effective load with the following formula:

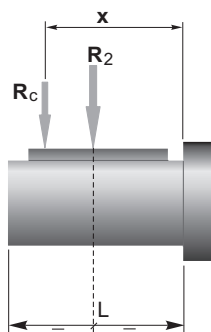

	CMB 402	CMB 502
a	86	104
b	66	79
R _{2MAX}	3500	4200

$$R_c = \frac{R_2 \cdot a}{(b + x)} \leq R_{2MAX}$$

$$R \leq R_c$$

a. b = valori riportati nella tabella
a. b = values given in the table

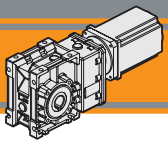

CMB402	BLS043.240													
	24V						36V							
	ir	n _{2MIN} [rpm]		n _{2MAX} [rpm]		n _{1MAX} [rpm]	n _{2MIN} [rpm]		n _{2MAX} [rpm]		n _{1MAX} [rpm]			
M ₂ [Nm]		sf	M ₂ [Nm]	sf	M ₂ [Nm]		sf	M ₂ [Nm]	sf					
6.2	49	2.5	18.4	486	2.5	12.5	3000	65	2.5	18.4	648	2.5	11.1	4000
7.5	40	3.0	15.2	400	3.0	10.3		53	3.0	15.2	534	3.0	9.1	
9.2	33	3.7	12.4	326	3.7	8.4		43	3.7	12.4	435	3.7	7.4	
11.8	25	4.8	10.8	254	4.8	7.3		34	4.8	10.8	338	4.8	6.5	
12.5	24	5.0	10.3	240	5.0	7.0		32	5.0	10.3	320	5.0	6.2	
14.8	20	6.0	8.6	202	6.0	5.9		27	6.0	8.6	270	6.0	5.2	
17.6	17	7.1	7.3	170	7.1	4.9		23	7.1	7.3	227	7.1	4.4	
18.6	16	7.5	8.4	161	7.5	5.7		22	7.5	8.4	215	7.5	5.0	
22.3	13	9.0	7.0	134	9.0	4.8		18	9.0	7.0	179	9.0	4.2	
23.9	13	9.7	6.5	125	9.7	4.4		17	9.7	6.5	167	9.7	3.9	
28.9	10	12	6.4	104	12	4.3		14	12	6.4	138	12	3.8	
30.8	9.7	12	6.0	97	12	4.1		13	12	6.0	130	12	3.6	
33.6	8.9	14	5.5	89	14	3.7		12	14	5.5	119	14	3.3	
35.6	8.4	14	5.2	84	14	3.5		11	14	5.2	112	14	3.1	
42.8	7.0	17	4.3	70	17	2.9		9.4	17	4.3	94	17	2.6	
55.3	5.4	22	3.3	54	22	2.3		7.2	22	3.3	72	22	2.0	
59.1	5.1	24	3.1	51	24	2.1		6.8	24	3.1	68	24	1.9	
64.3	4.7	26	2.9	47	26	2.0		6.2	26	2.9	62	26	1.7	
72.5	4.1	29	2.6	41	29	1.7		5.5	29	2.6	55	29	1.5	

Tipo Type	Numero di poli Number of poles	Numero di fasi Number of phase	Tensione Rated voltage [V]	Numero di giri Rated speed [rpm]	Coppia nominale Rated torque [Nm]	Potenza nominale Rated power [W]
BLS043.240	4	3	36	4000	0.43	180
			24	3000		130
Tipo Type	Coppia massima Peak torque [Nm]	Corrente nominale Rated current [A]	Resistenza Resistance [ohm]	Induttanza Inductance [mH]	Corrente massima Peak current [A]	Peso Weight [kg]
BLS043.240	0.86	6	0.35	1	12.0	1.25

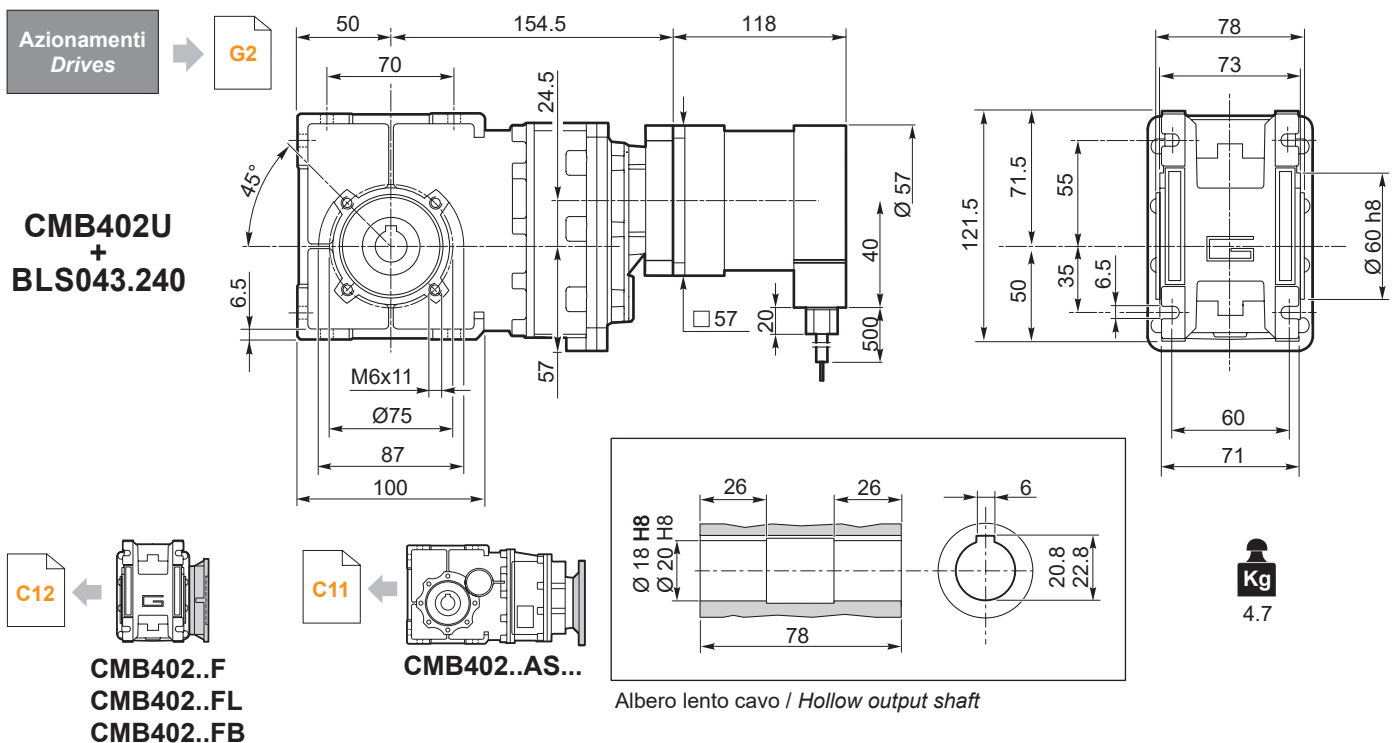

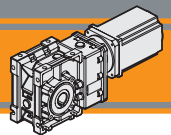

CMB402 con motore brushless

CMB402 with brushless motor

CMB402	BL070.240 / BL070.480 / BL070.48B					
	24V / 48V					
	ir	n _{2MIN} [rpm]			n _{2MAX} [rpm]	
M ₂ [Nm]		sf		M ₂ [Nm]	sf	n _{1MAX} [rpm]
6.2	49	4.1	11.3	486	4.1	7.7
7.5	40	4.9	9.3	400	4.9	6.3
9.2	33	6.1	7.6	326	6.1	5.2
11.8	25	7.8	6.6	254	7.8	4.5
12.5	24	8.2	6.3	240	8.2	4.3
14.8	20	9.8	5.3	202	9.8	3.6
17.6	17	12	4.5	170	12	3.0
18.6	16	12	5.2	161	12	3.5
22.3	13	15	4.3	134	15	2.9
23.9	13	16	4.0	125	16	2.7
28.9	10	19	3.9	104	19	2.7
30.8	9.7	20	3.7	97	20	2.5
33.6	8.9	22	3.4	89	22	2.3
35.6	8.4	23	3.2	84	23	2.2
42.8	7.0	28	2.7	70	28	1.8
55.3	5.4	36	2.1	54	36	1.4
59.1	5.1	39	1.9	51	39	1.3
64.3	4.7	42	1.8	47	42	1.2
72.5	4.1	48	1.6	41	48	1.1

BLCMB

Tipo Type	Numero di poli Number of poles	Numero di fasi Number of phase	Tensione Rated voltage [V]	Numero di giri Rated speed [rpm]	Coppia nominale Rated torque [Nm]	Potenza nominale Rated power [W]
BL070.240	8	3	24	3000	0.7	220
BL070.480 BL070.48B	8	3	48	3000	0.7	220

Tipo Type	Coppia massima Peak torque [Nm]	Corrente nominale Rated current [A]	Resistenza Resistance [ohm]	Induttanza Inductance [mH]	Corrente massima Peak current [A]	Peso Weight [kg]
BL070.240	2.1	13	0.091	0.23	26	2.1
BL070.480 BL070.48B	1.4	6.5	0.34	1.0	13	2.1

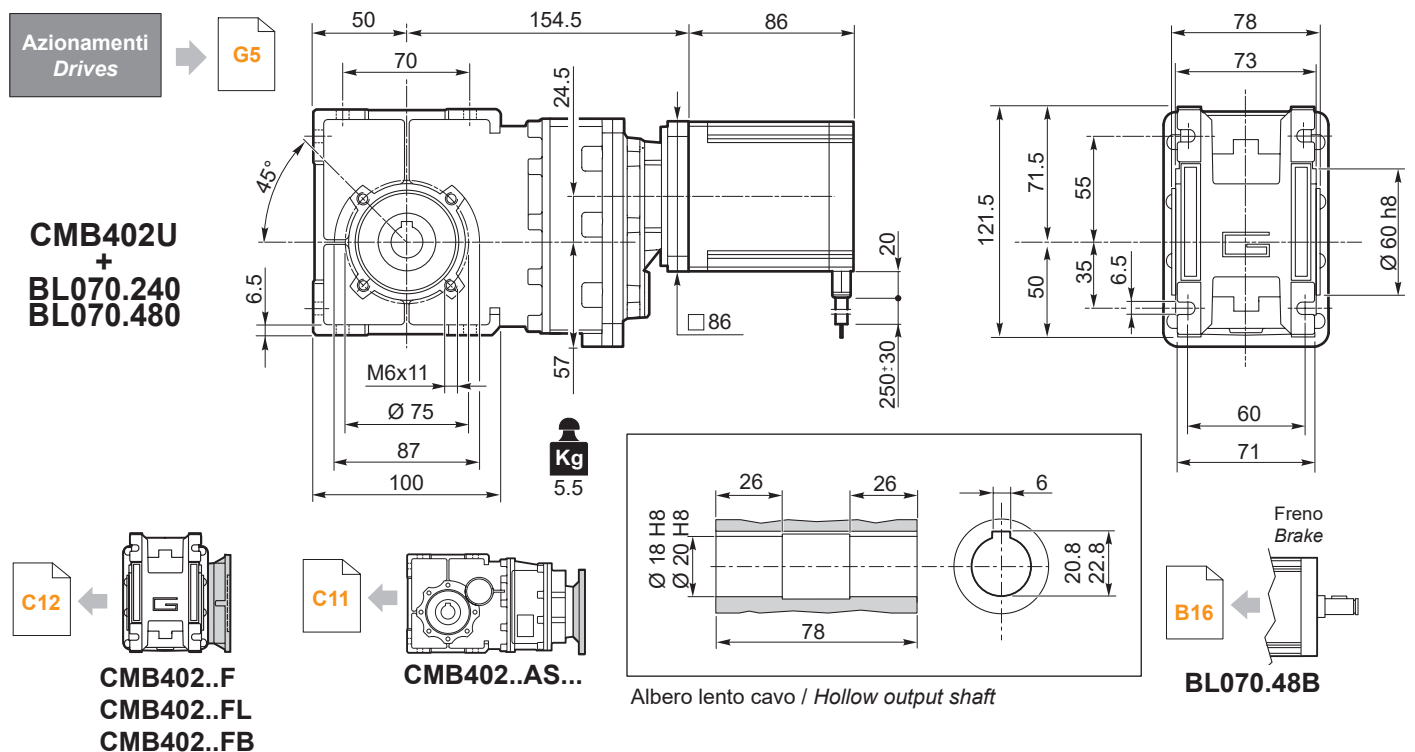

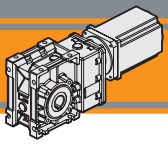

CMB402	BL140.480					
	48V					
	ir	n _{2MIN} [rpm]			n _{2MAX} [rpm]	
M ₂ [Nm]		sf		M ₂ [Nm]	sf	n _{1MAX} [rpm]
6.2	49	8.1	5.7	486	8.1	3.8
7.5	40	9.9	4.7	400	9.9	3.2
9.2	33	12.1	3.8	326	12.1	2.6
11.8	25	15.6	3.3	254	15.6	2.3
12.5	24	16.4	3.1	240	16.4	2.1
14.8	20	19.5	2.7	202	19.5	1.8
17.6	17	23	2.2	170	23	1.5
18.6	16	24	2.6	161	24	1.8
22.3	13	29	2.2	134	29	1.5
23.9	13	31	2.0	125	31	1.4
28.9	10	38	2.0	104	38	1.3
30.8	9.7	41	1.8	97	41	1.2
33.6	8.9	44	1.7	89	44	1.1
35.6	8.4	47	1.6	84	47	1.1
42.8	7.0	56	1.3	70	56	0.9
55.3	5.4	73	1.0	54	72	0.7
59.1	5.1	78	1.0	51	72	0.7
64.3	4.7	85	0.9	47	72	0.7
72.5	4.1	95	0.8	41	72	0.7

Attenzione: superamento della coppia nominale supportata dal riduttore per servizio S1.
Contattare il ns. servizio tecnico
*Attention: rated torque withstood by gear reducer for service in S1 is exceeded.
Please. contact our technical office.*

Tipo Type	Numero di poli Number of poles	Numero di fasi Number of phase	Tensione Rated voltage [V]	Numero di giri Rated speed [rpm]	Coppia nominale Rated torque [Nm]	Potenza nominale Rated power [W]
BL140.480	8	3	48	3000	1.4	440
Tipo Type	Coppia massima Peak torque [Nm]	Corrente nominale Rated current [A]	Resistenza Resistance [ohm]	Induttanza Inductance [mH]	Corrente massima Peak current [A]	Peso Weight [kg]
BL140.480	2.8	13.0	0.16	0.5	26	3.15

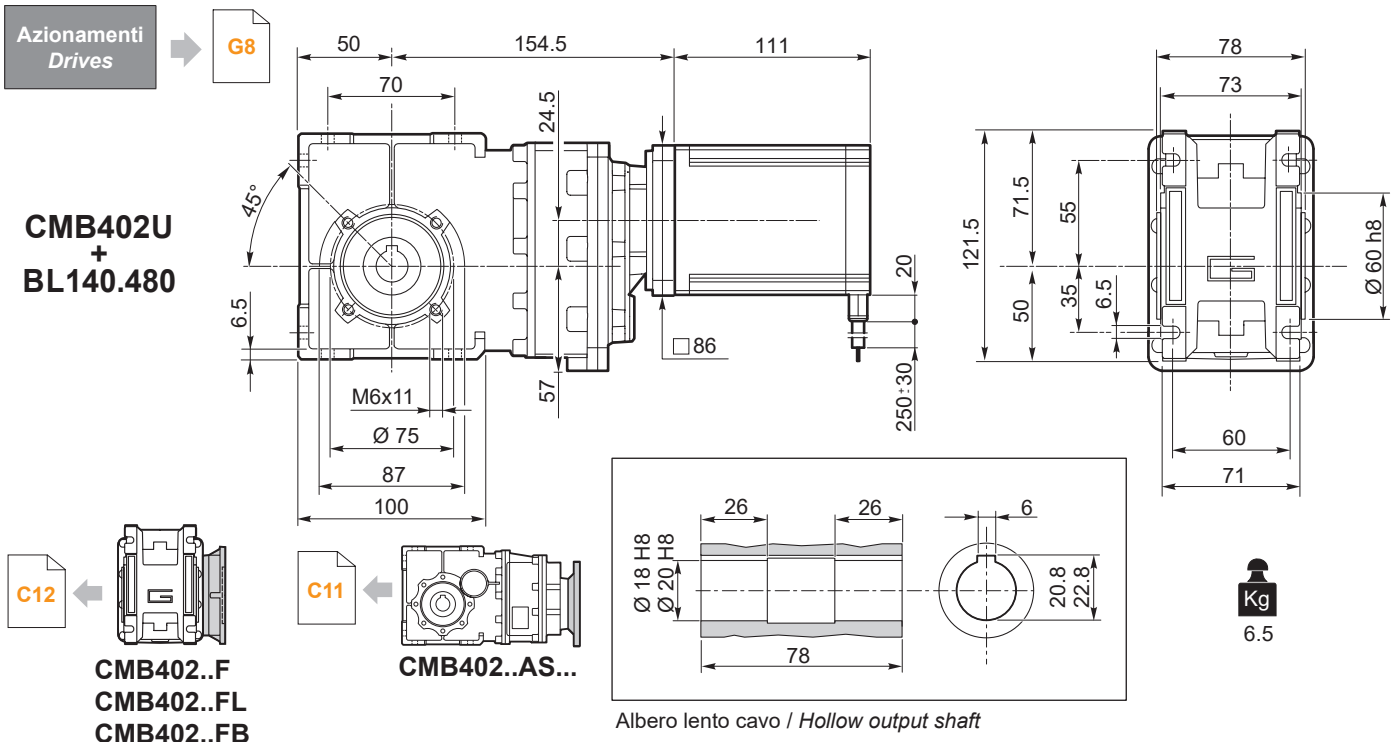

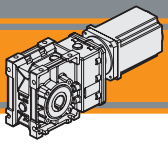

CMB502	BL140.480					
	48V					
	ir	n _{2MIN} [rpm]			n _{2MAX} [rpm]	
M ₂ [Nm]		sf		M ₂ [Nm]	sf	n _{1MAX} [rpm]
6.2	49	8.1	9.9	486	8.1	6.7
7.5	40	9.9	8.2	400	9.9	5.5
9.2	33	12.1	6.6	326	12.1	4.5
11.8	25	15.6	6.6	254	15.6	4.5
12.5	24	16.4	6.3	240	16.4	4.3
14.8	20	19.5	5.3	202	19.5	3.6
17.6	17	23	4.5	170	23	3.0
18.6	16	24	5.2	161	24	3.5
22.3	13	29	4.3	134	29	2.9
23.9	13	31	4.0	125	31	2.7
28.9	10	38	3.8	104	38	2.6
30.8	9.7	41	3.5	97	41	2.4
33.6	8.9	44	3.3	89	44	2.2
35.6	8.4	47	3.1	84	47	2.1
42.8	7.0	56	2.6	70	56	1.7
55.3	5.4	73	2.0	54	73	1.3
59.1	5.1	78	1.8	51	78	1.3
64.3	4.7	85	1.7	47	85	1.2
72.5	4.1	95	1.5	41	95	1.0

Attenzione: superamento della coppia nominale supportata dal riduttore per servizio S1.
Contattare il ns. servizio tecnico
*Attention: rated torque withstood by gear reducer for service in S1 is exceeded.
Please. contact our technical office.*

Tipo Type	Numero di poli Number of poles	Numero di fasi Number of phase	Tensione Rated voltage [V]	Numero di giri Rated speed [rpm]	Coppia nominale Rated torque [Nm]	Potenza nominale Rated power [W]
BL140.480	8	3	48	3000	1.4	440
Tipo Type	Coppia massima Peak torque [Nm]	Corrente nominale Rated current [A]	Resistenza Resistance [ohm]	Induttanza Inductance [mH]	Corrente massima Peak current [A]	Peso Weight [kg]
BL140.480	2.8	13.0	0.16	0.5	26	3.15

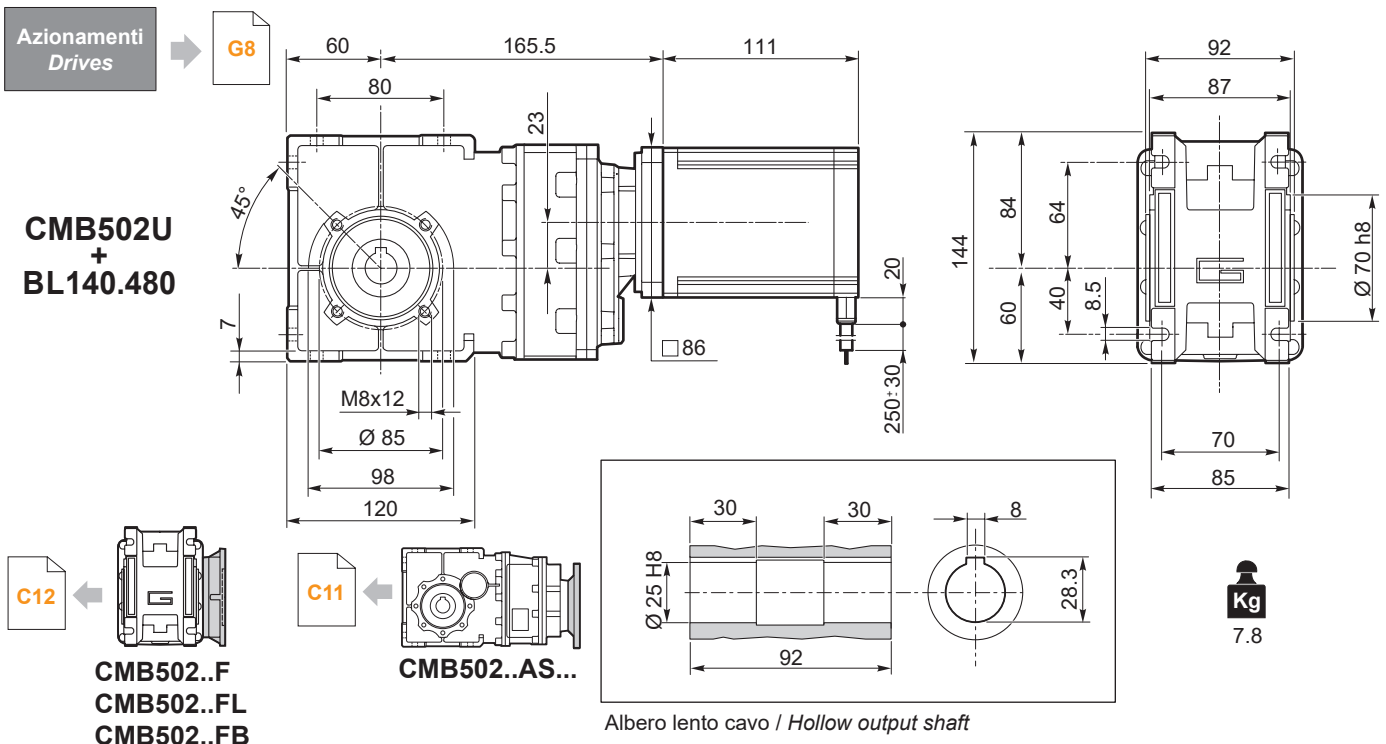

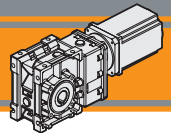

CMB502 con motore brushless

CMB502 with brushless motor

CMB502	BL210.480 / BL210.48E					
	48V					
	ir	n _{2MIN} [rpm]			n _{2MAX} [rpm]	
M ₂ [Nm]		sf		M ₂ [Nm]	sf	n _{1MAX} [rpm]
6.2	49	12	6.6	486	12	4.5
7.5	40	15	5.4	400	15	3.7
9.2	33	18	4.4	326	18	3.0
11.8	25	23	4.4	254	23	3.0
12.5	24	25	4.2	240	25	2.8
14.8	20	29	3.5	202	29	2.4
17.6	17	35	3.0	170	35	2.0
18.6	16	37	3.4	161	37	2.3
22.3	13	44	2.9	134	44	1.9
23.9	13	47	2.7	125	47	1.8
28.9	10	57	2.5	104	57	1.7
30.8	9.7	61	2.4	97	61	1.6
33.6	8.9	66	2.2	89	66	1.5
35.6	8.4	70	2.0	84	70	1.4
42.8	7.0	84	1.7	70	84	1.2
55.3	5.4	109	1.3	54	109	0.9
59.1	5.1	117	1.2	51	117	0.8
64.3	4.7	127	1.1	47	127	0.8
72.5	4.1	143	1.0	41	139	0.7

BLCMB

Attenzione: superamento della coppia nominale supportata dal riduttore per servizio S1.
Contattare il ns. servizio tecnico
Attention: rated torque withstood by gear reducer for service in S1 is exceeded.
Please. contact our technical office.

Tipo Type	Numero di poli Number of poles	Numero di fasi Number of phase	Tensione Rated voltage [V]	Numero di giri Rated speed [rpm]	Coppia nominale Rated torque [Nm]	Potenza nominale Rated power [W]
BL210.480 BL210.48E	8	3	48	3000	2.1	660
Tipo Type	Coppia massima Peak torque [Nm]	Corrente nominale Rated current [A]	Resistenza Resistance [ohm]	Induttanza Inductance [mH]	Corrente massima Peak current [A]	Peso Weight [kg]
BL210.480 BL210.48E	4.2	18.7	0.115	0.31	37	4.2

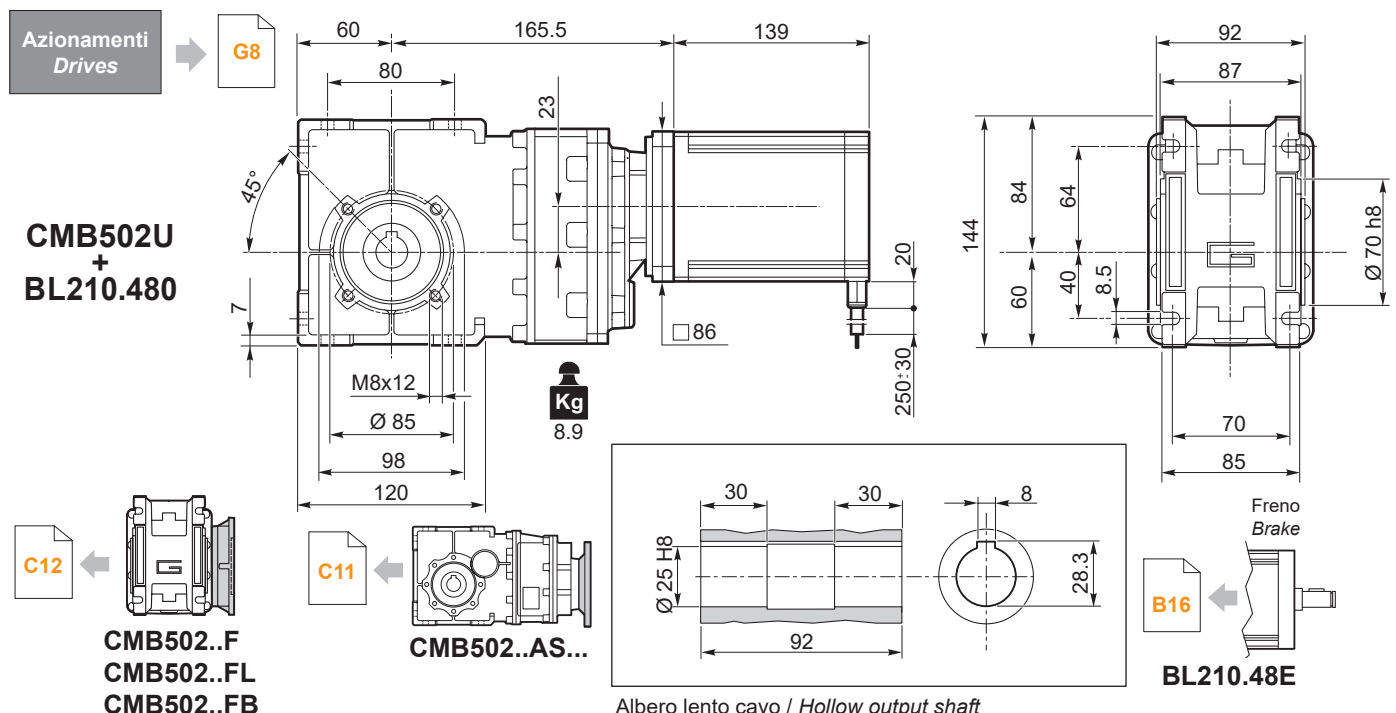

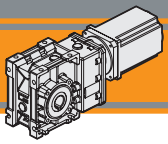

BLCMB

Motoriduttori brushless CC ad assi ortogonali Brushless DC helical bevel gearmotors

Dati tecnici

Technical data

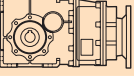
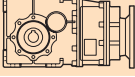
	n_2 [min ⁻¹]	Mn_2 [Nm]	Pn_1 [kW]	i		n_2 [min ⁻¹]	Mn_2 [Nm]	Pn_1 [kW]	i
CMB 402					CMB 402				
$n_1 = 1400$ rpm	227	40	1.0	6.18	$n_1 = 3000$ rpm	486	31.2	1.65	6.18
	187	40	0.83	7.49		400	31.2	1.36	7.49
	152	40	0.68	9.2		326	31.2	1.11	9.20
	118	45	0.59	11.83		254	35.1	0.97	11.83
	112	45	0.56	12.48		240	35.1	0.92	12.48
	94.4	45	0.47	14.83		202	35.1	0.77	14.83
	79.4	45	0.40	17.63		170	35.1	0.65	17.63
	75.3	55	0.46	18.6		161	42.9	0.75	18.60
	62.7	55	0.38	22.33		134	42.9	0.63	22.33
	58.6	55	0.36	23.91		126	42.9	0.59	23.91
	48.5	65	0.35	28.89		104	50.7	0.57	28.89
	45.4	65	0.33	30.84		97.3	50.7	0.54	30.84
	41.7	65	0.30	33.57		89.4	50.7	0.49	33.57
	39.3	65	0.28	35.63		84.2	50.7	0.47	35.63
	32.7	65	0.24	42.75		70.2	50.7	0.39	42.75
	25.3	65	0.18	55.31		54.2	50.7	0.30	55.31
	23.7	65	0.17	59.06		50.8	50.7	0.28	59.06
	21.8	65	0.16	64.29		46.7	50.7	0.26	64.29
	19.3	65	0.14	72.50		41.4	50.7	0.23	72.50

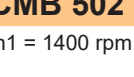
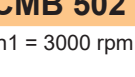
	n_2 [min ⁻¹]	Mn_2 [Nm]	Pn_1 [kW]	i		n_2 [min ⁻¹]	Mn_2 [Nm]	Pn_1 [kW]	i
CMB 502					CMB 502				
$n_1 = 1400$ rpm	227	70	1.8	6.18	$n_1 = 3000$ rpm	486	54.6	2.89	6.18
	187	70	1.5	7.49		400	54.6	2.38	7.49
	152	70	1.2	9.20		326	54.6	1.94	9.20
	118	90	1.2	11.83		254	70.2	1.94	11.83
	112	90	1.1	12.48		240	70.2	1.84	12.48
	94.4	90	0.95	14.83		202	70.2	1.55	14.83
	79.4	90	0.80	17.63		170	70.2	1.30	17.63
	75.3	110	0.92	18.60		161	85.8	1.51	18.60
	62.7	110	0.77	22.33		134	85.8	1.26	22.33
	58.6	110	0.72	23.91		126	85.8	1.17	23.91
	48.5	125	0.67	28.89		104	97.5	1.10	28.89
	45.4	125	0.63	30.84		97.3	97.5	1.03	30.84
	41.7	125	0.58	33.57		89.4	97.5	0.95	33.57
	39.3	125	0.55	35.63		84.2	97.5	0.90	35.63
	32.7	125	0.46	42.75		70.2	97.5	0.75	42.75
	25.3	125	0.35	55.31		54.2	97.5	0.58	55.31
	23.7	125	0.33	59.06		50.8	97.5	0.54	59.06
	21.8	125	0.30	64.29		46.7	97.5	0.50	64.29
	19.3	125	0.27	72.50		41.4	97.5	0.44	72.50

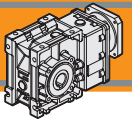

Dimensioni CMB con flange motore AS

CMB dimensions with motor flanges AS

CMB402 - U - AS...

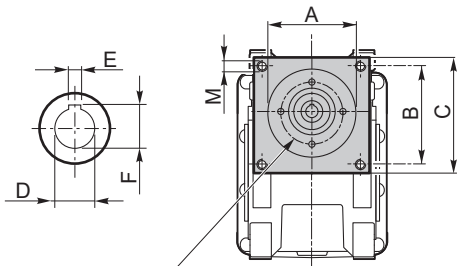

Connessione con boccola o giunto in funzione del diametro dell'albero motore.

Connection with sleeve or coupling depending on motorshaft's diameter.

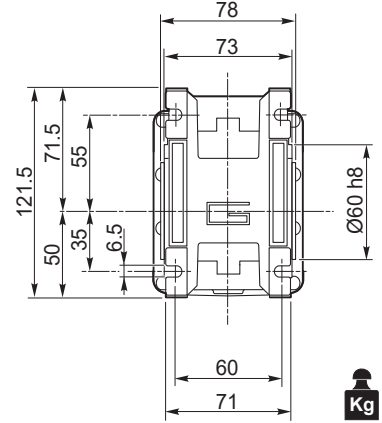
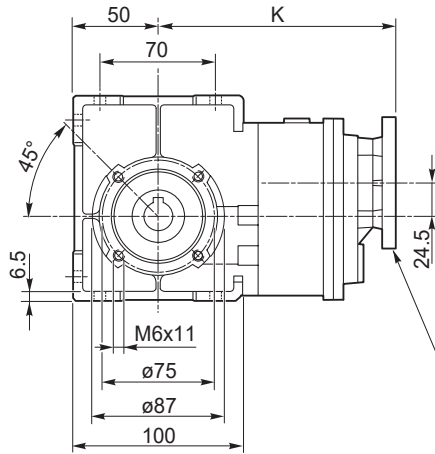
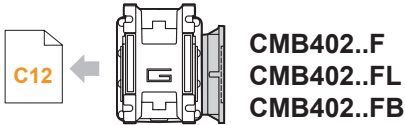

Lo spessore della flangia è variabile in funzione delle diverse lunghezze dell'albero motore.

Flange's thickness may vary depending on motorshaft's length.

Dimensioni / Dimensions								
AS	A	B	C	M	K	D	E	F
AS392	38.1	47.1	64	M5	154.5	9	3	10.5
						11	4	12.8
						14	5	16.3
AS384	73	69.6	86	M5	154.5	9	3	10.5
						11	4	12.8
						14	5	16.3
...

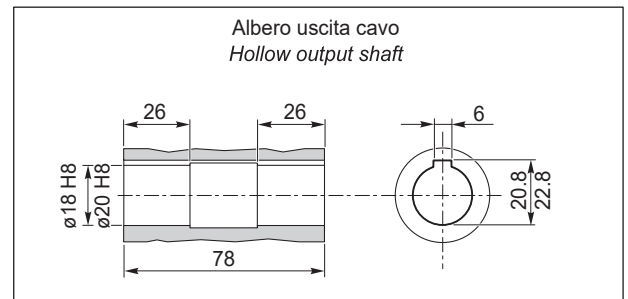

CMB502 - U - AS...

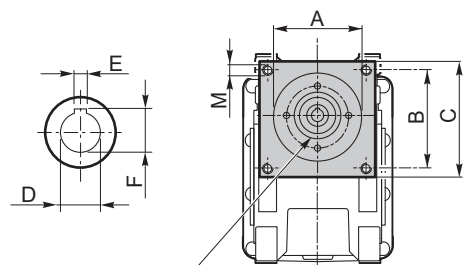

Connessione con boccola o giunto in funzione del diametro dell'albero motore.

Connection with sleeve or coupling depending on motorshaft's diameter.

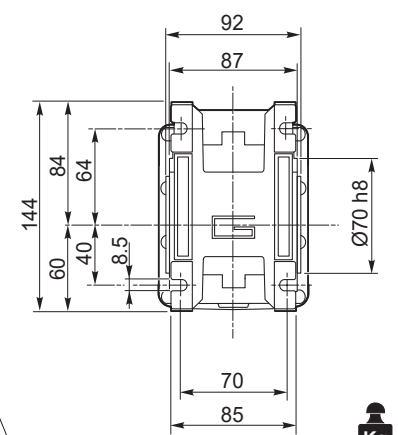
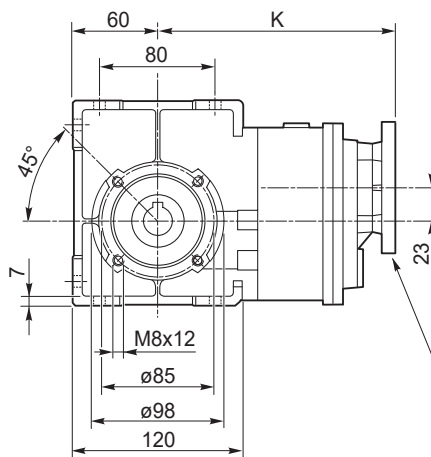
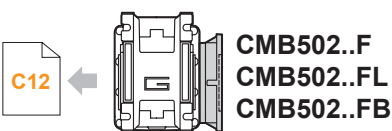

Lo spessore della flangia è variabile in funzione delle diverse lunghezze dell'albero motore.

Flange's thickness may vary depending on motorshaft's length.

Dimensioni / Dimensions								
AS	A	B	C	M	K	D	E	F
AS384	73	69.6	86	M5	165.5	9	3	10.5
						11	4	12.8
						14	5	16.3
...

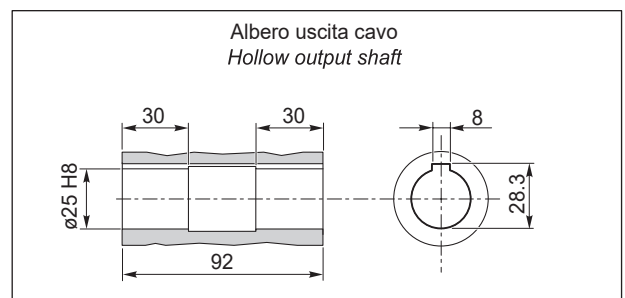

BLCMB

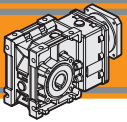

Flange uscita / Output flanges																														
CMB	F										FL										FB									
	a ₁	KA	KB	KC	KM	KN H8	KO	KP	KQ	a ₁	KA	KB	KC	KM	KN H8	KO	KP	KQ	a ₁	KA	KB	KC	KM	KN H8	KO	KP	KQ			
402	45°	67	7.5	4.5	80-95	60	9	110	95	45°	97	7.5	4.5	80-95	60	9	110	95	45°	80	8.5	5	115-125	95	9.5	140	112			
502	45°	90	9	5	90-110	70	11	125	110	45°	120	9	5	90-110	70	11	125	110	45°	89	9	5	130-145	110	9.5	160	132			

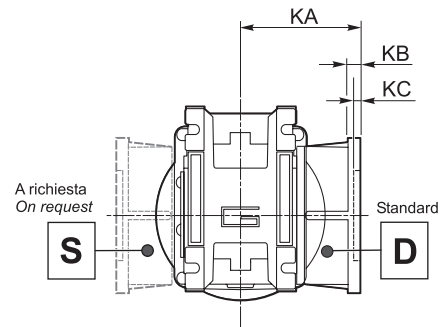
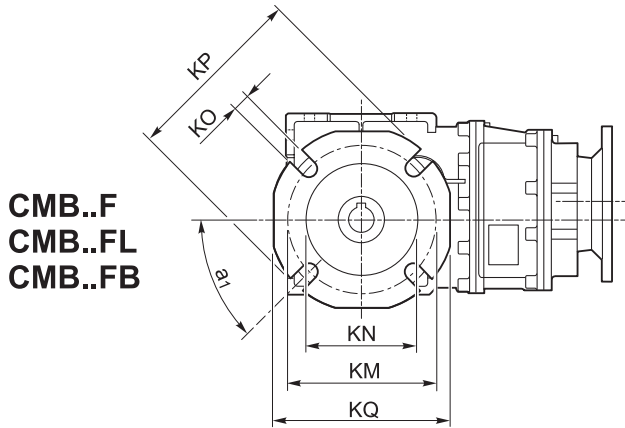

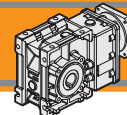

Accessori

Accessories

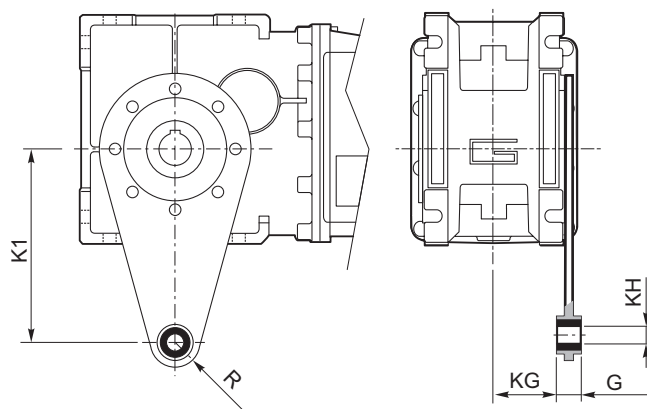
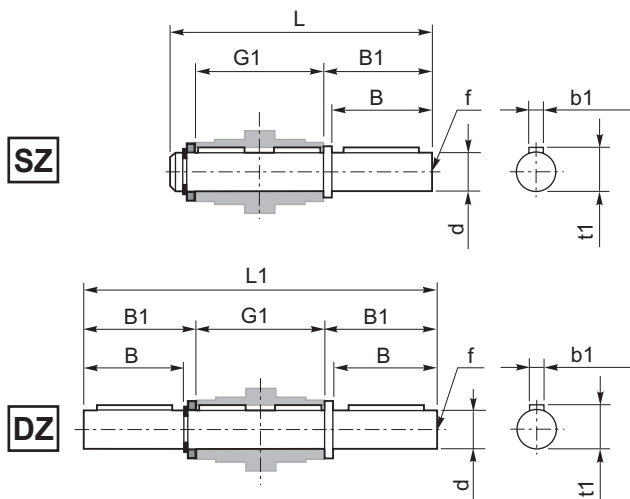

Albero lento / Output shaft

CMB	d h7	B	B1	G1	L	L1	f	b1	t1
402	18	40	43	78	128	164	M6	6	20.5
502	25	50	53.5	92	153	199	M10	8	28

Braccio di reazione / Torque arm

CMB	K1	G	KG	KH	R
402	100	14	31	10	18
502	100	14	38	10	18

SC - Safety cover

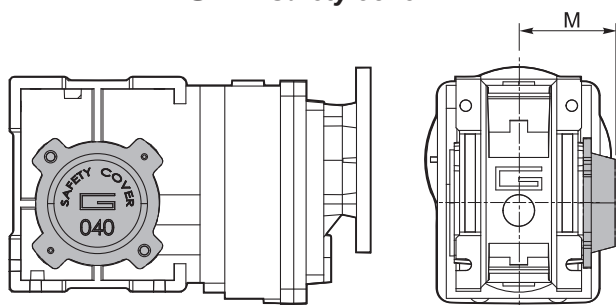

CMB	M
402	54.5
502	62.5

WD - Kit washdown cover

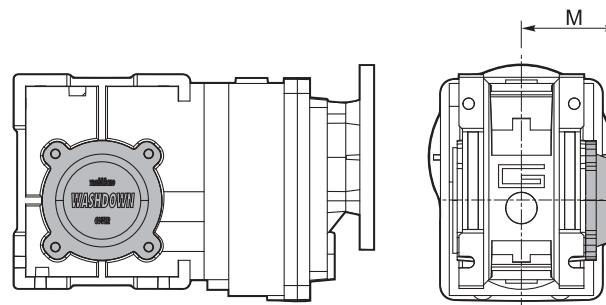

CMB	M
402	55.5
502	63.5

BLCMB

 **TRANSTECNO SRL**
HEADQUARTERS
Via Caduti di Sabbiano, 11/D-E
40011 Anzola dell'Emilia (BO)
ITALY
T+39 051 64 25 811
F +39 051 73 49 43
sales@transtecno.com
www.transtecno.com

**TRANSTECNO**[®]
the modular gearmotor

CATBLDCALU0920

MEMBER OF INTERPUMP GROUP



 **HANGZHOU TRANSTECNO POWER TRANSMISSIONS CO LTD**
No.4 Xiuyan Road Fengdu Industry Zone
Pingyao Town Yuhang District
Hangzhou City, Zhejiang Province
311115 - CHINA
T +86 571 86 92 02 60
F +86 571 86 92 18 10
info-china@transtecno.cn
www.transtecno.cn

 **MA TRANSTECNO S.A.P.I. DE C.V.**
Av. Mundial # 176, Parque Industrial
JM Apodaca, Nuevo León,
C.P. 66600 - MÉXICO
T +52 8113340920
info@transtecno.com.mx
www.transtecno.com.mx

 **TRANSTECNO IBÉRICA**
THE MODULAR GEARMOTOR, S.A.
C/Enginy. 2 Nave 6
08850 Gavà (Barcelona) - SPAIN
T +34 931 598 950
info@transtecno.es
www.transtecno.es

 **TRANSTECNO B.V.**
De Stuwdam,43
3815 KM Amersfoort - NETHERLANDS
T +31(0) 33 45 19 505
F +31(0) 33 45 19 506
info@transtecno.nl
www.transtecno.nl

 **TRANSTECNO AANDRIJFTECHNIEK B.V.**
De Stuwdam 43
3815 KM Amersfoort - NETHERLANDS
T +31 (0) 33 20 4 7 006
info@transtecnoaandrijftechnik.nl
www.transtecnoaandrijftechnik.nl

 **TRANSTECNO USA**
8 Creek Parkway,
Boothwyn PA 19061-8136
UNITED STATES
T + 1 (610) 4970154
F +1 (610) 497 6085

14561 Frylands Blvd SE
Monroe, WA 98272 - UNITED STATES
T +1 360-863-1300
F +1 360-863-1303
usaoffice@transtecno.com
www.transtecno.com

 **TRANSTECNO CANADA**
51 B Caldari Road Unit 10
Vaughan, ON L4K 4G3 - CANADA
T +1 905 761 0762
F +1 905 761 9265
canadaoffice@transtecno.com
www.transtecno.com

 **TRANSTECNO CHILE-PERU**
Av. Los Libertadores 41
Parque Industrial - Los Libertadores 16.500
Santiago, Colina - CHILE
T +56 2 29633870
Carretera Panamericana Sur KM 29.5,
Interior I-3, Z.I. Lurin - PERU
T +51 1 3546259 / + 51 1 3434231
chileoffice@transtecno.com
www.transtecno.com

 **SALES OFFICE BRAZIL**
Rua Dr. Freire Alemão 155 / 402 - CEP. 90450-060
Auxiliadora Porto Alegre RS - BRAZIL
T +55 51 3251 5447
F +55 51 3251 5447
M +55 51 811 45 962
braziloffice@transtecno.com
www.transtecno.com.br

 **SALES OFFICE OCEANIA**
44 Northview drive, Sunshine west 3020
Victoria - AUSTRALIA
T +61 03 9312 4722
F +61 03 9312 4714
M +61 0438060997
oceaniaoffice@transtecno.com
www.transtecno.com.au

 **SALES OFFICE INDIA**
Woodbine 2003/04, Everest Road
Kolshet Road, Thane west Mumbai 400607
INDIA
T +91 982 061 46 98
indiaoffice@transtecno.com
www.transtecno.com

 **SALES OFFICE SOUTH KOREA**
410-7. Samrae-eup, Wanju-goon, Chonbuk 55332
SOUTH KOREA
T +82 70 8867 8897
F +82 504 199 2107
M +82 10 5094 2107
koreaoffice@transtecno.com
www.transtecno.com