

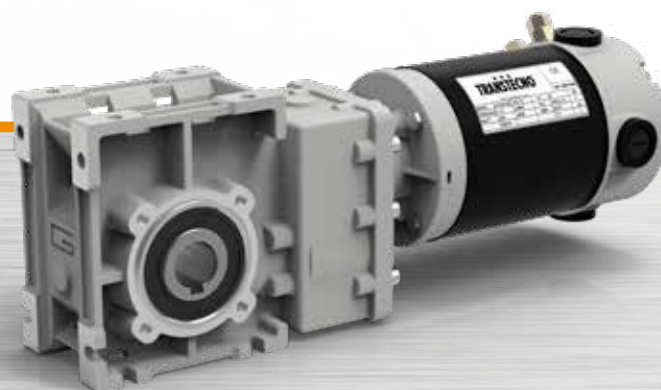

Ferrite

Motoriduttori CC ad assi ortogonali
DC helical bevel gearmotors

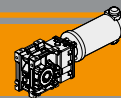



Indice	Index	Pag. Page
Caratteristiche tecniche	<i>Technical features</i>	M2
Designazione	<i>Classification</i>	M2
Sensi di rotazione	<i>Direction of rotation</i>	M2
Simbologia	<i>Symbols</i>	M3
Lubrificazione	<i>Lubrication</i>	M3
Carichi radiali	<i>Radial loads</i>	M3
Dati tecnici per servizio S2	<i>Technical data for S2 duty</i>	M4
Motori applicabili	<i>Motor adapters</i>	M6
Dimensioni	<i>Dimensions</i>	M7
Accessori	<i>Accessories</i>	M18

Questa sezione annulla e sostituisce ogni precedente edizione o revisione. Qualora questa sezione non Vi sia giunta in distribuzione controllata, l'aggiornamento dei dati ivi contenuto non è assicurato. **In tal caso la versione più aggiornata è disponibile sul nostro sito internet www.transtecno.com**

This section replaces any previous edition and revision. If you obtained this catalogue other than through controlled distribution channels, the most up to date content is not guaranteed. In this case the latest version is available on our web site www.transtecno.com

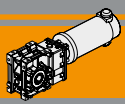

Caratteristiche tecniche

Technical features

Le caratteristiche principali dei motoriduttori CC ad assi ortogonali a magneti permanenti in ferrite serie ECMB sono:

The main features of ECMB ferrite permanent magnets DC helical bevel gearmotors range are:

- Alimentazione in bassa tensione 12/24 Vcc
- Possibilità di montaggio encoder
- Potenze motore disponibili da 100 a 800W S2
- Magneti in ferrite
- Carcasse dei riduttori in pressofusione di alluminio
- Lubrificazione permanente con olio sintetico
- Ingranaggi sempre rettificati

- Low voltage power supply 12/24 Vdc
- Suitable for encoder assembly
- Motor power ratings available from 100 to 800W S2
- Ferrite magnets
- Die-cast aluminum housing
- Permanent synthetic oil long-life lubrication
- Ground helical gears

Designazione

Classification

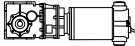
MOTORIDUTTORE / GEARMOTOR													
ECMB	100/402						U	9.2	D20	SZDX	BRSX	90	240
Tipo Type	Grandezza Size						Versione Riduttore Gearbox Version	Rapporto Ratio	Albero di uscita Output shaft	Albero di uscita Output shaft	Braccio di reazione Torque arm	Angolo Angle	Versione Motore Motor Version
	070/402	100/402	180/402	250/402	350/402	600/402	U	Vedere tabella	Vedere tabella	SZDX SZSX DZ	BRDX BRSX	0° 90° 180° 270°	120 240 24E
	070/502	100/502	180/502	250/502	350/502	600/502	FD						
	070/633	100/633	180/633	250/633	350/633	600/633 350/903 600/903	FS FLD FLS FBD FBS	See tables	See tables		*		

Versione Riduttore
Gearbox Version

Albero di uscita
Output shaft

Braccio di reazione
Torque arm *

Angolo
Angle

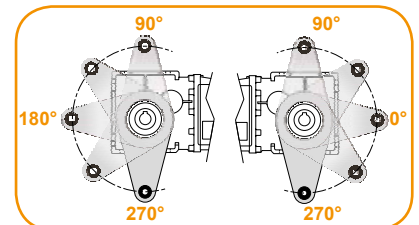
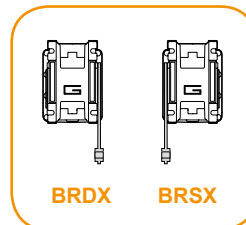
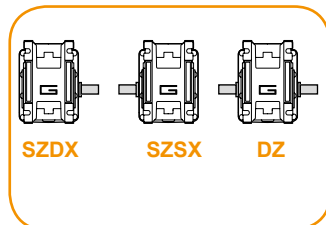
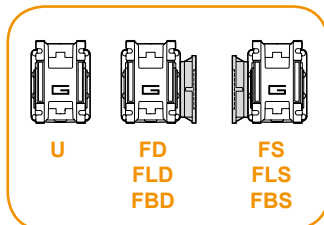

* NOTA: il braccio di reazione viene fornito smontato.
NOTE: the torque arm will be supplied not assembled.

Sensi di rotazione

Direction of rotation

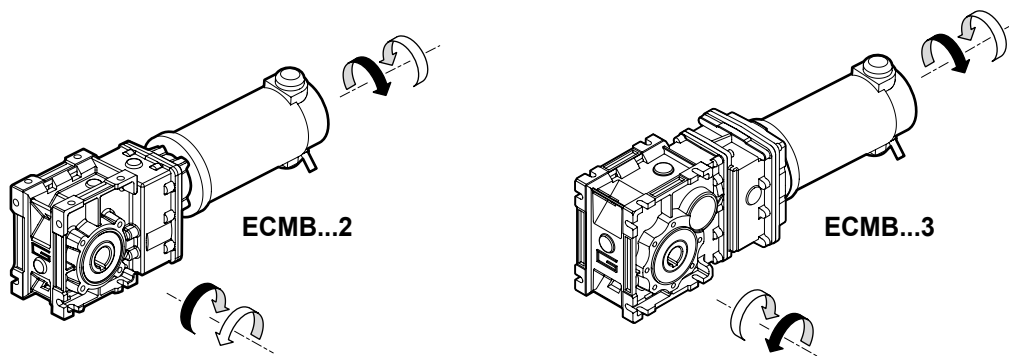

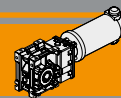

Simbologia

Symbols

n_1 [min⁻¹] Velocità in ingresso / *Input speed*
 n_2 [min⁻¹] Velocità in uscita / *Output speed*
i Rapporto di riduzione / *Ratio*
 P_1 [kW] Potenza in entrata / *Input power*

M_2 [Nm] Coppia in uscita in funzione di P_1 / *Output torque referred to P_1*
sf Fattore di servizio / *Service factor*
 A_2 [N] Carico assiale ammissibile in uscita / *Permitted output axial load*
 R_2 [N] Carico radiale ammissibile in uscita / *Permitted output radial load*

Lubrificazione

Lubrication

Tutti i riduttori nelle taglie 402, 502 e 633 sono forniti completi di lubrificante sintetico viscosità 320, pertanto possono essere installati in qualunque posizione di montaggio e non necessitano di manutenzione.

Permanent synthetic oil long-life lubrication (viscosity grade 320) makes it possible to use sizes 402, 502 and 603 in all mounting positions; for this reason they can be installed in any assembly position and do not require maintenance.

Carichi radiali

Radial loads

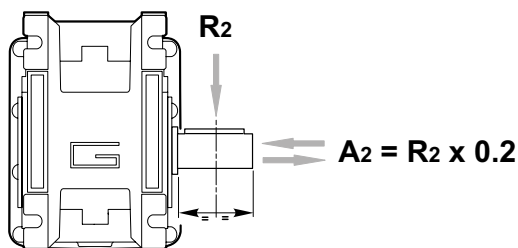

n_2 [min ⁻¹]	R_2 [N]			
	CMB 402	CMB 502	CMB 633	CMB 903
400	905	1116	1835	2682
300	996	1228	2020	2952
200	1141	1406	2312	3379
170	1204	1484	2441	3567
140	1414	1743	2604	3806
100	1582	1949	2913	4686
90	1638	2019	3321	4853
60	2047	2490	3801	5556
40	2524	3029	4492	6614
30	2778	3334	5159	7540
20	3180	3816	5906	8631
15	3500	4200	6500	9500
10	3500	4200	6500	9500

Quando il carico radiale risultante non è applicato sulla mezza-
ria dell'albero occorre calcolare quello effettivo con la seguente
formula:

*When the resulting radial load is not applied on the centre line
of the shaft it is necessary to calculate the effective load with the
following formula:*

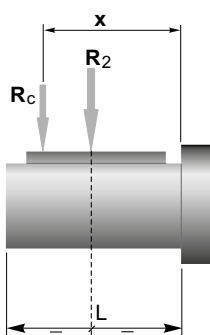

	CMB 402	CMB 502	CMB 633	CMB 903
a	86	104	118	157
b	66	79	93	117
R_{2MAX}	3500	4200	6500	9500

$$R_c = \frac{R_2 \cdot a}{(b + x)} \leq R_{2MAX}$$

$$R \leq R_c$$

*a, b = valori riportati nella tabella
a, b = values given in the table*

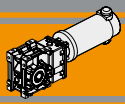

Dati tecnici per servizio S2

Technical data for S2 duty

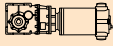
P ₁ [W]	n ₂ [min ⁻¹]	M ₂ [Nm]	sf	i		Versione motore Motor version
100						
(3000 min ⁻¹)	485	1.8	16.8	6.18	070/402	12E/24E
	401	2.2	13.8	7.49		
	326	2.8	11.3	9.20		
	254	3.5	9.9	11.83		
	240	3.7	9.4	12.48		
	202	4.4	7.9	14.83		
	170	5.3	6.6	17.63		
	161	5.6	7.7	18.60		
	134	6.7	6.4	22.33		
	125	7.2	6.0	23.91		
	104	8.6	5.9	28.89		
	97	9.2	5.5	30.84		
	89	10	5.1	33.57		
	84	11	4.8	35.63		
	70	13	4.0	42.75		
	54	17	3.1	55.31		
	51	18	2.9	59.06		
	47	19	2.7	64.29		
	41	22	2.4	72.50		
	54	17	5.9	55.31	070/502	12E/24E
	51	18	5.5	59.06		
	47	19	5.1	64.29		
	41	22	4.5	72.50		
	41	22	8.8	73.96	070/633	12E/24E
	38	24	8.3	78.58		
	32	28	7.0	93.33		
	21	42	4.6	140.52		
	17	54	3.6	181.81		
	14	63	3.1	211.31		
	13	71	2.7	238.31		

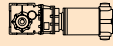
P ₁ [W]	n ₂ [min ⁻¹]	M ₂ [Nm]	sf	i		Versione motore Motor version
140						
(3000 min ⁻¹)	41	31	6.3	73.96	100/633	120/240/24E
	38	33	5.9	78.58		
	32	39	5.0	93.33		
	21	59	3.3	140.52		
	17	76	2.6	181.81		
	14	89	2.2	211.31		
	13	100	2.0	238.31		

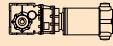
P ₁ [W]	n ₂ [min ⁻¹]	M ₂ [Nm]	sf	i		Versione motore Motor version		
250								
(3000 min ⁻¹)	485	4.6	6.7	6.18	180/402	120/240/24E		
	401	5.6	5.5	7.49				
	326	6.9	4.5	9.20				
	254	8.8	4.0	11.83				
	240	9.3	3.7	12.48				
	202	11	3.2	14.83				
	170	13	2.7	17.63				
	161	14	3.1	18.60				
	134	17	2.6	22.33				
	125	18	2.4	23.91				
	104	22	2.4	28.89				
	97	23	2.2	30.84				
	89	25	2.0	33.57				
	84	27	1.9	35.63				
	70	32	1.6	42.75				
	54	41	1.2	55.31				
	51	44	1.2	59.06				
	47	48	1.1	64.29				
	41	54	0.9	72.50				
	134	17	5.1	22.33			180/502	120/240/24E
	125	18	4.8	23.91				
	104	22	4.5	28.89				
	97	23	4.2	30.84				
	89	25	3.9	33.57				
	84	27	3.7	35.63				
	70	32	3.1	42.75				
	54	41	2.4	55.31				
	51	44	2.2	59.06				
	47	48	2.0	64.29				
	41	54	1.8	72.50				
	52	43	4.5	57.93	180/633	120/240/24E		
	49	46	4.2	61.63				
	41	55	3.5	73.96				
	38	59	3.3	78.58				
	32	70	2.8	93.33				
	21	105	1.9	140.52				
	17	136	1.4	181.81				
	14	158	1.2	211.31				
	13	178	1.1	238.31				

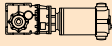
P ₁ [W]	n ₂ [min ⁻¹]	M ₂ [Nm]	sf	i		Versione motore Motor version
140						
(3000 min ⁻¹)	485	2.6	12.0	6.18	100/402	120/240/24E
	401	3.1	9.9	7.49		
	326	3.9	8.0	9.20		
	254	5.0	7.1	11.83		
	240	5.2	6.7	12.48		
	202	6.2	5.6	14.83		
	170	7.4	4.7	17.63		
	161	7.8	5.5	18.60		
	134	9.4	4.6	22.33		
	125	10	4.3	23.91		
	104	12	4.2	28.89		
	97	13	3.9	30.84		
	89	14	3.6	33.57		
	84	15	3.4	35.63		
	70	18	2.8	42.75		
	54	23	2.2	55.31		
	51	25	2.1	59.06		
	47	27	1.9	64.29		
	41	30	1.7	72.50		
	54	23	4.2	55.31	100/502	120/240/24E
	51	25	4.0	59.06		
	47	27	3.6	64.29		
	41	30	3.2	72.50		

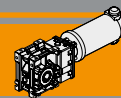

Dati tecnici per servizio S2

Technical data for S2 duty

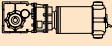
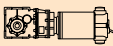
P ₁ [W]	n ₂ [min ⁻¹]	M ₂ [Nm]	sf	i		Versione motore Motor version	P ₁ [W]	n ₂ [min ⁻¹]	M ₂ [Nm]	sf	i		Versione motore Motor version	
350							500							
(3000 min ⁻¹)	485	6.5	4.8	6.18	250/402	120/240	(3000 min ⁻¹)	485	9	3.4	6.18	350/402	120/240	
	401	7.8	4	7.49					401	11	2.8			7.49
	326	9.6	3.2	9.20					326	14	2.3			9.2
	254	12	2.8	11.83					254	18	2.0			11.83
	240	13	2.7	12.48					240	19	1.9			12.48
	202	16	2.3	14.83					202	22	1.6			14.83
	170	19	1.9	17.63					170	26	1.3			17.63
	161	20	2.2	18.60					161	28	1.5			18.6
	134	23	1.8	22.33					134	33	1.3			22.33
	125	25	1.7	23.91					125	36	1.2			23.91
	104	30	1.7	28.89					104	43	1.2			28.89
	97	32	1.6	30.84					97	46	1.1			30.84
	89	35	1.5	33.57					89	50	1.0			33.57
	84	37	1.4	35.63					84	53	1.0			35.63
	70	45	1.1	42.75					70	64	0.8			42.75
	54	58	0.9	55.31					54	73	0.7			55.31
	51	62	0.8	59.06					51	73	0.7			59.06
	47	67	0.8	64.29					47	73	0.7			64.29
	41	72	0.7	72.50					41	73	0.7			64.29
	485	6.5	8.5	6.18			250/502	120/240		326	14			4.0
	401	7.8	7.0	7.49					254	18	4.0	11.83		
	326	9.6	5.7	9.2					240	19	3.7	12.48		
	254	12	5.7	11.83					202	22	3.2	14.83		
	240	13	5.4	12.48					170	26	2.7	17.63		
	202	16	4.5	14.83					161	28	3.1	18.60		
	170	19	3.8	17.63					134	33	2.6	22.33		
	161	20	4.4	18.6					125	36	2.4	23.91		
	134	23	3.7	22.33					104	43	2.3	28.89		
	125	25	3.4	23.91					97	46	2.1	30.84		
	104	30	3.2	28.89					89	50	2.0	33.57		
	97	32	3.0	30.84					84	53	1.8	35.63		
	89	35	2.8	33.57					70	64	1.5	42.75		
	84	37	2.6	35.63					54	83	1.2	55.31		
	70	45	2.2	42.75					51	88	1.1	59.06		
	54	58	1.7	55.31					47	96	1.0	64.29		
	51	62	1.6	59.06					41	109	0.9	72.50		
	47	67	1.5	64.29										
	41	76	1.3	72.50										
	106	30	5.8	28.17	250/633	120/240				139	32	5.3	21.56	350/633
	89	35	4.9	33.81					113	40	4.3	26.48		
	84	38	4.6	35.92					106	42	4.1	28.17		
	77	41	4.8	38.88					89	51	3.4	33.81		
	64	49	4.0	47.16					84	54	3.2	35.92		
	52	61	3.2	57.93					77	58	3.4	38.88		
	49	65	3.0	61.63					64	71	2.8	47.16		
	41	78	2.5	73.96					52	87	2.2	57.93		
	38	82	2.4	78.58					49	92	2.1	61.63		
	32	98	2.0	93.33					41	111	1.8	73.96		
	21	147	1.3	140.52					38	118	1.7	78.58		
	17	190	1.0	181.81					32	140	1.4	93.33		
	14	221	0.9	211.31					21	210	0.9	140.52		
	13	250	0.8	238.31					17	272	0.7	181.81		
							14	279	0.7	211.31				

NOTA

Verificare sempre che la coppia M₂ utilizzata non ecceda il valore indicato nelle caselle in grigio

NOTE

Please check that the output torque M₂ does not exceed the value in the grey areas



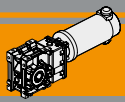

Dati tecnici per servizio S2

Technical data for S2 duty

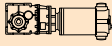
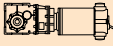
P ₁ [W]	n ₂ [min ⁻¹]	M ₂ [Nm]	sf	i		Versione motore Motor version	P ₁ [W]	n ₂ [min ⁻¹]	M ₂ [Nm]	sf	i		Versione motore Motor version	
500							800							
(3000 min ⁻¹)	63	71	5.5	47.25	3350/903	120/240	(3000 min ⁻¹)	97	74	1.3	30.84	600/502	120/240	
	52	86	4.5	57.52			89	80	1.2	33.57				
	45	99	3.9	66.17			84	85	1.1	35.63				
	36	124	3.1	83.2			70	102	1.0	42.75				
	28	162	2.4	108.09			54	132	0.7	55.31				
	23	198	2.0	132.23			51	140	0.7	59.06				
	20	221	1.8	147.92			47	140	0.7	64.29				
	18	250	1.6	167.09			41	140	0.7	72.50				
	16	286	1.4	191.06			306	23	5.0	9.81	600/633			120/240
	14	332	1.2	221.88			287	25	4.7	10.44				
	11	393	1.0	262.96			239	30	3.9	12.53				
					225	32	3.7	13.31						
					190	38	3.5	15.81						
					169	43	4.0	17.77						
					139	52	3.3	21.56						
					113	63	2.7	26.48						
					106	67	2.6	28.17						
					89	81	2.1	33.81						
					84	86	2.0	35.92						
					77	93	2.1	38.88						
					64	113	1.7	47.16						
					52	139	1.4	57.93						
					49	148	1.3	61.63						
					41	177	1.1	73.96						
					38	188	1.0	78.58						
					32	223	0.9	93.33						
					21	279	0.7	140.52						
					114	63	5.6	26.30	600/903	120/240				
					99	72	4.8	30.25						
					76	94	4.1	39.26						
					63	113	3.4	47.25						
					52	138	2.8	57.52						
					45	158	2.5	66.17						
					36	199	2.0	83.20						
					28	259	1.5	108.09						
					23	317	1.2	132.23						
					20	354	1.1	147.92						
					18	400	1.0	167.09						
					16	457	0.9	191.06						
					14	531	0.7	221.88						
					11	557	0.7	262.96						

NOTA
Verificare sempre che la coppia M₂ utilizzata non ecceda il valore indicato nelle caselle in grigio
NOTE
Please check that the output torque M₂ does not exceed the value in the grey areas

Motori applicabili

Motor adapters

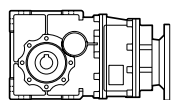
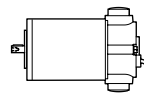

		EC					
		070.12E 070.24E	100.120 100.240 100.24E	180.120 180.240 180.24E	250.120 250.240	350.120 350.240	600.120 600.240
CMB	402	6.18 - 72.50					
	502	6.18 - 72.50					
	633	6.58 - 238.31					
	933						6.65 - 262.96

6.18 - 72.50 Rapporti di riduzione i
Ratio i

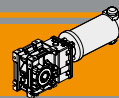

Dimensioni

Dimensions

ECMB070/402 U

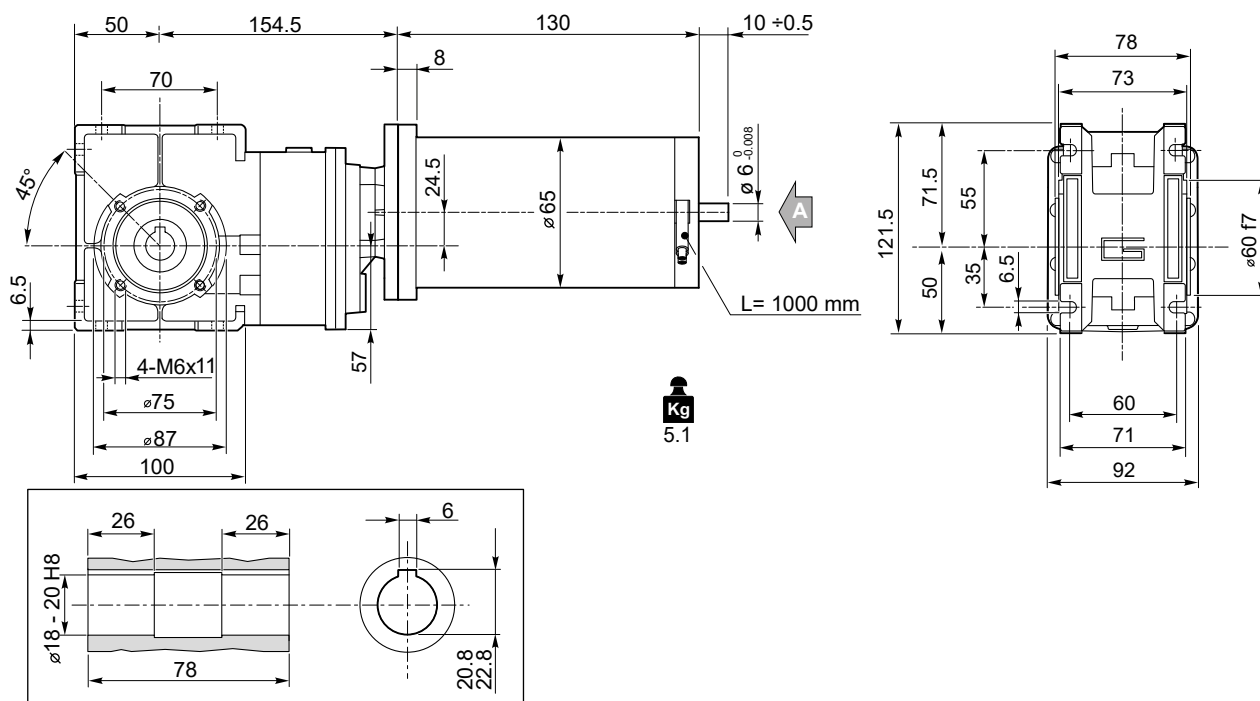

ECMB070/502 U

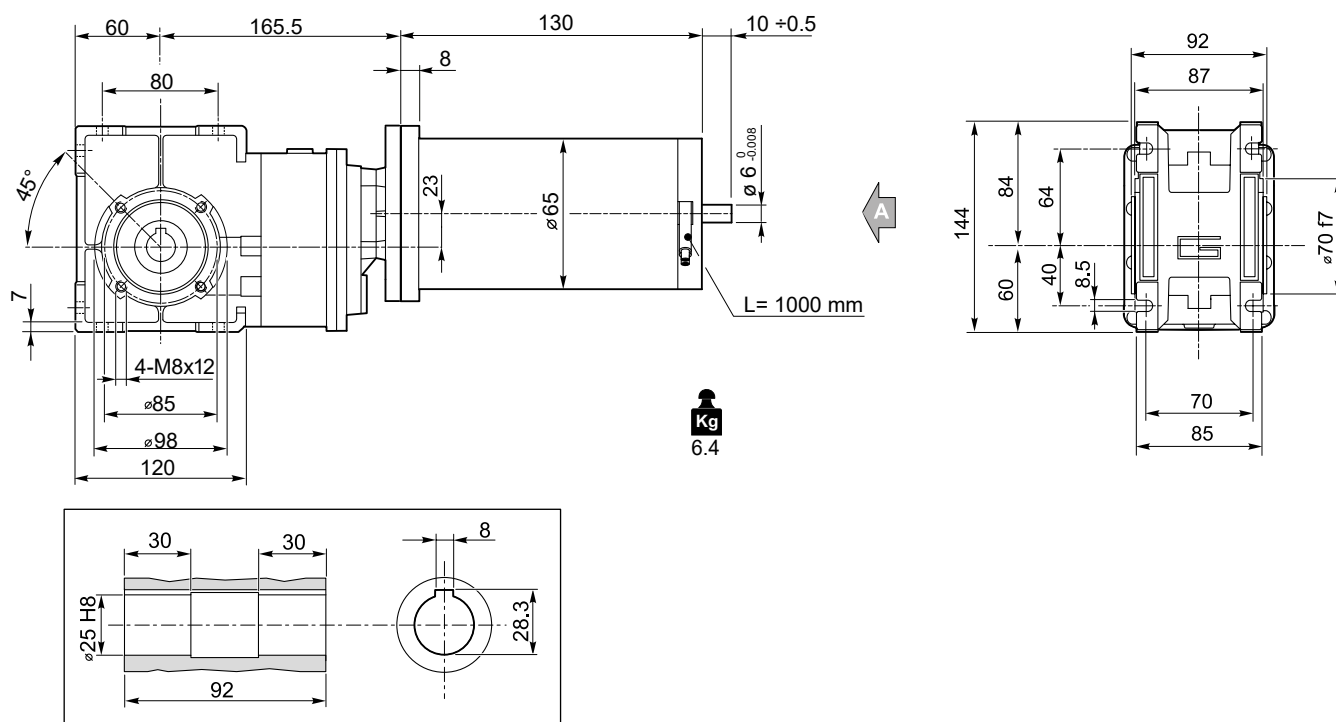

ECMB

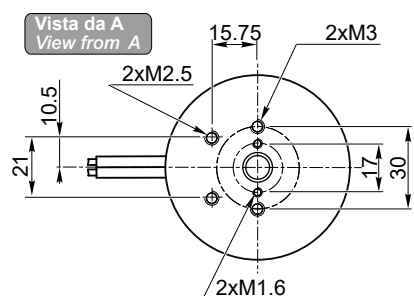

Freno / Brake



Encoder



Motori / Motors IP66

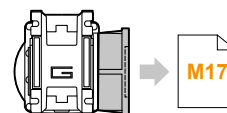

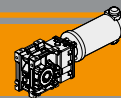

Dimensioni

Dimensions

ECMB100/502 U

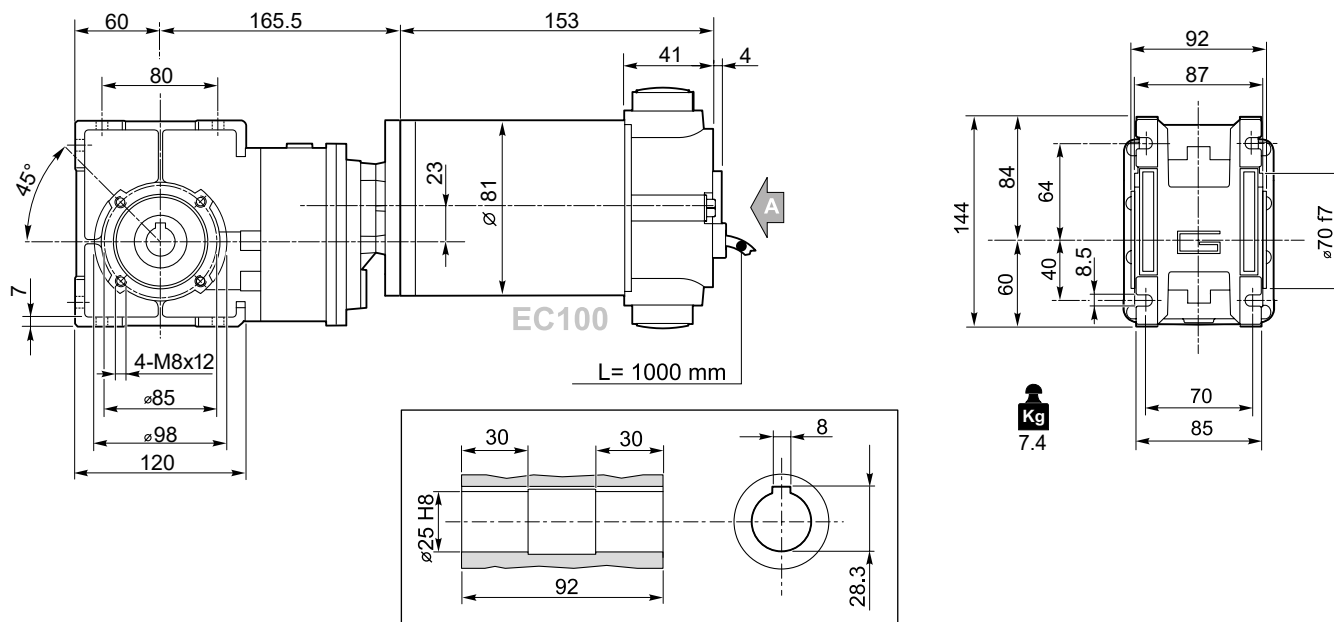

ECMB100/633 U

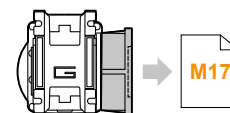
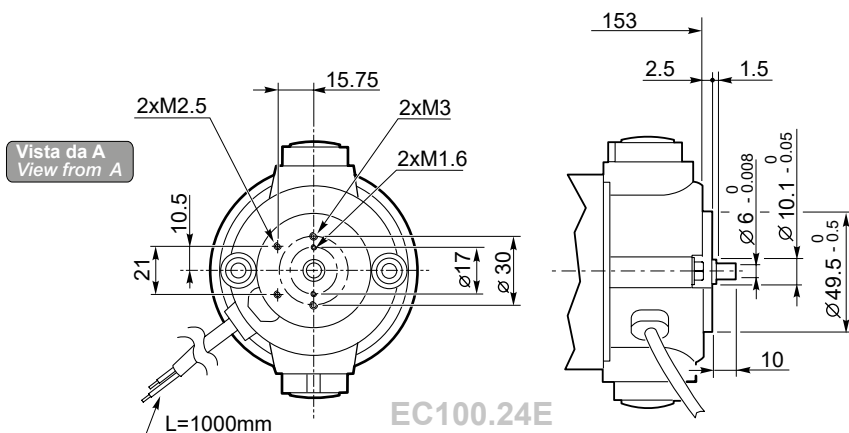
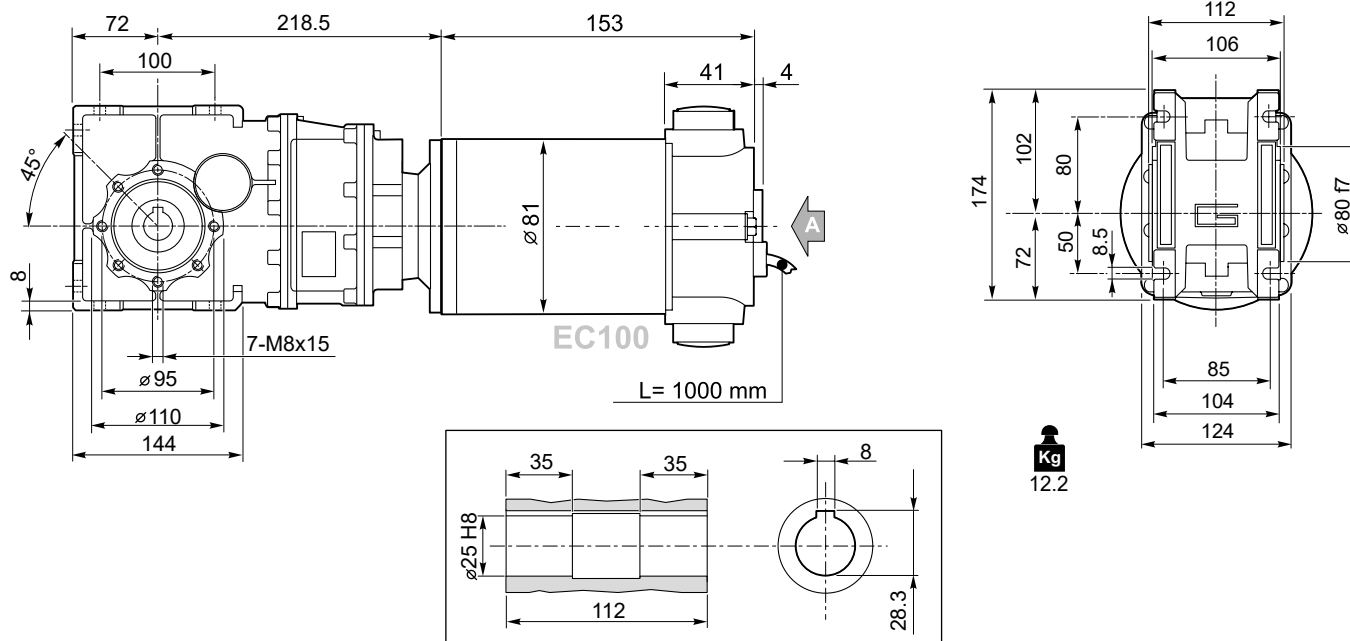

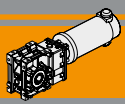

Dimensioni

Dimensions

ECMB180/402 U

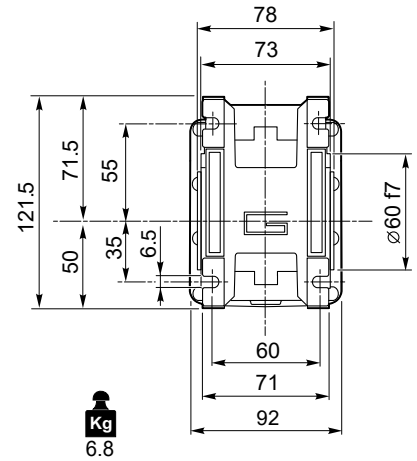
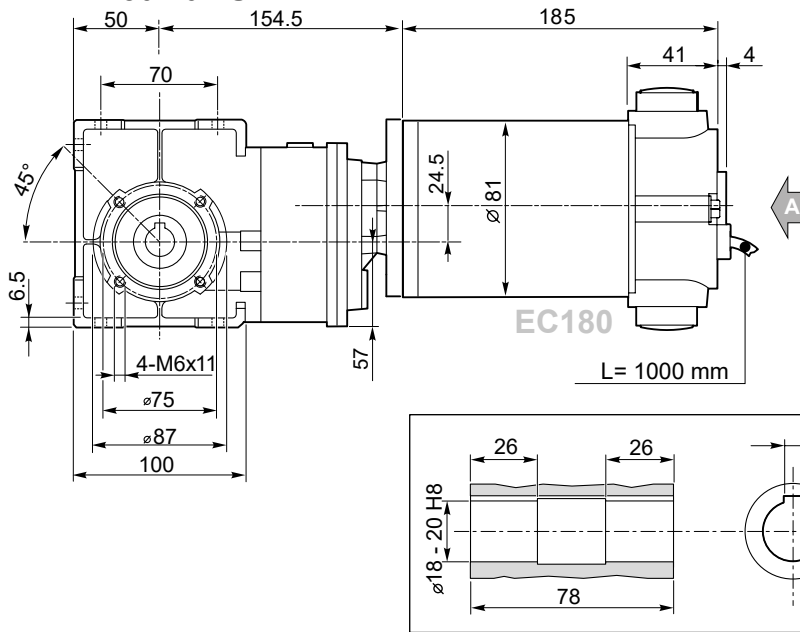

ECMB180/502 U

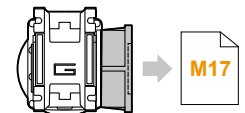
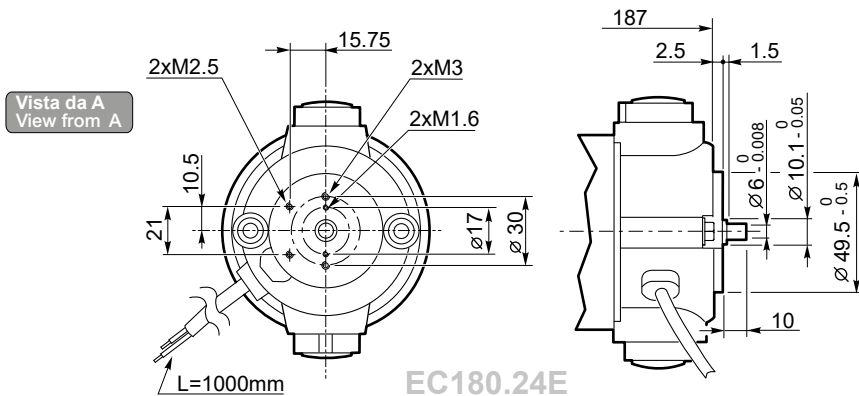
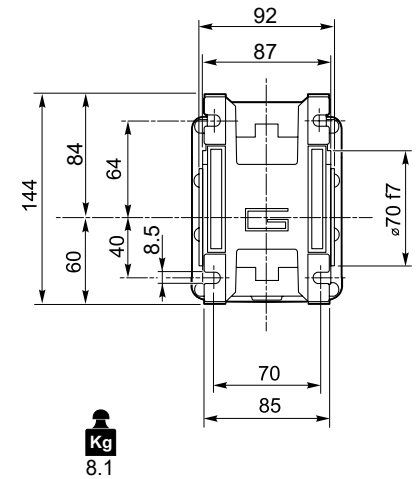
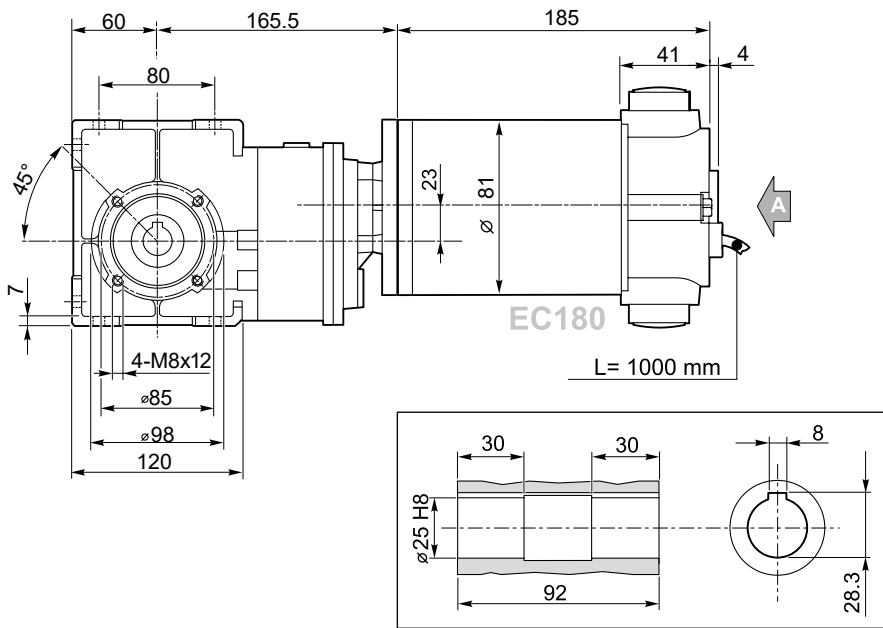

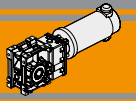

Dimensioni

Dimensions

ECMB180/633 U

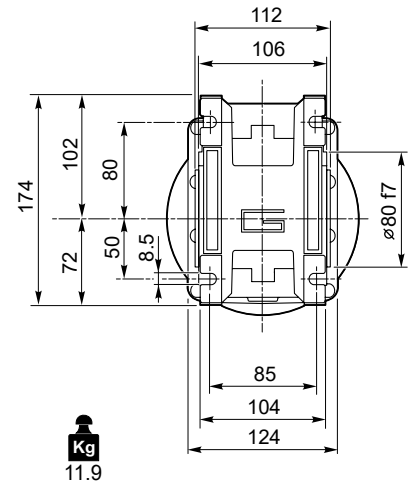
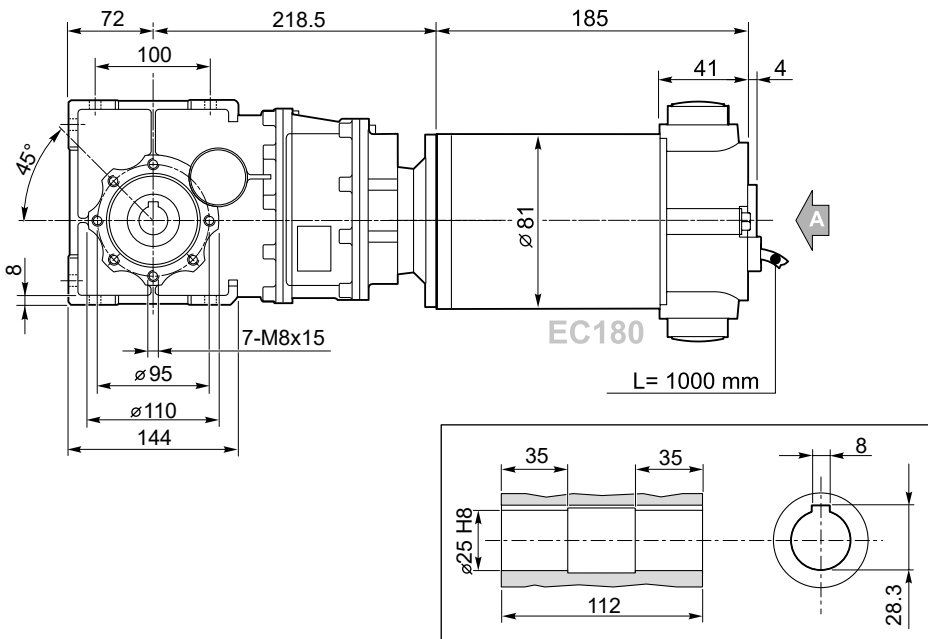

Vista da A
View from A

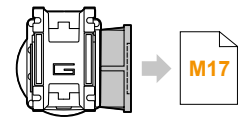
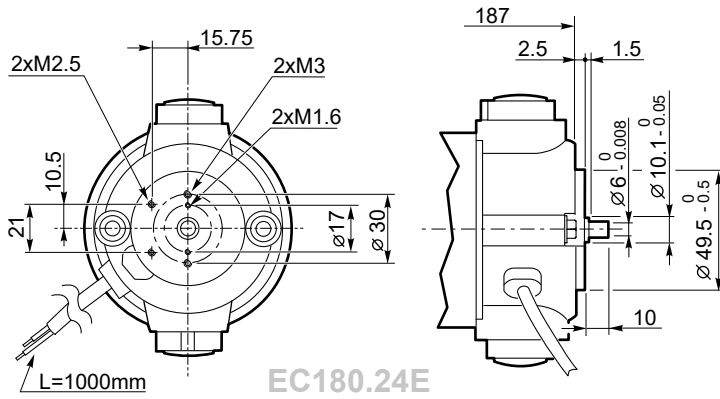

ECMB

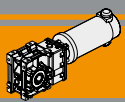

Dimensioni

Dimensions

ECMB250/402 U

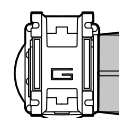
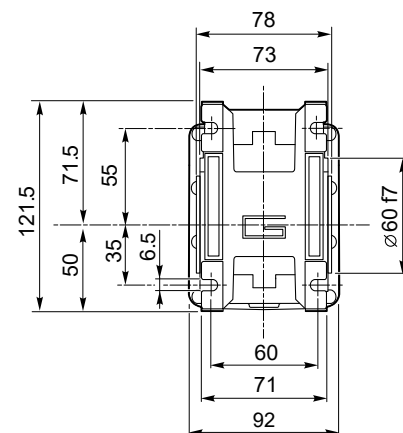
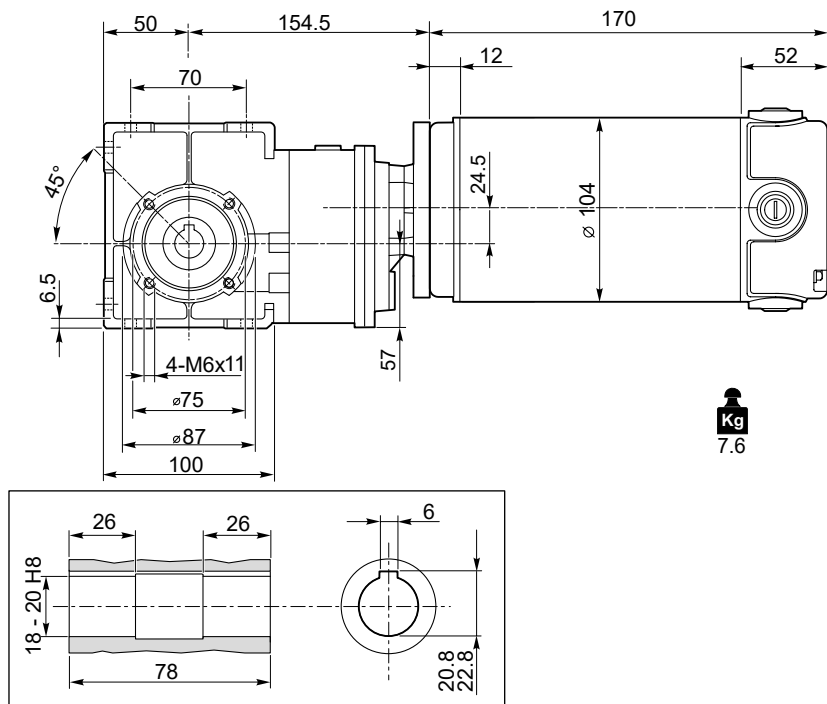

M17

Motori / Motors IP66

I8

ECMB250/502 U

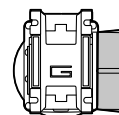
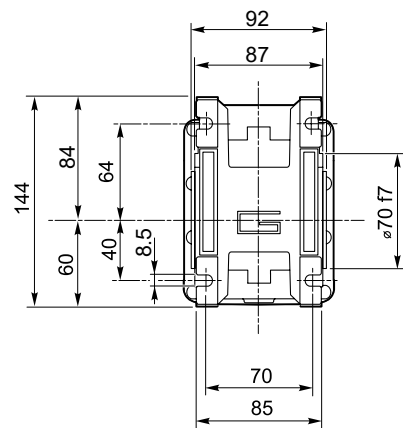
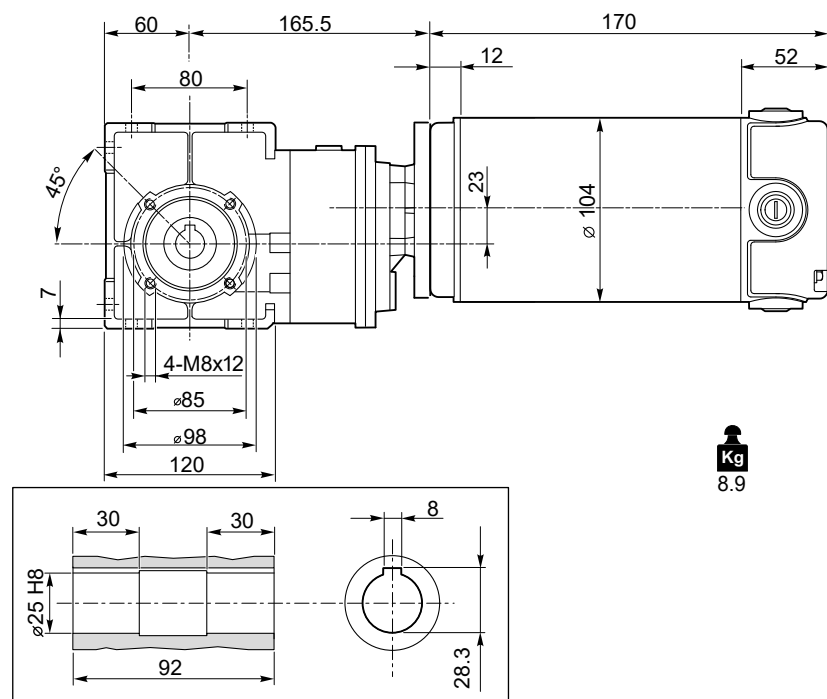

M17

Motori / Motors IP66

I8

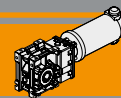

Dimensioni

Dimensions

ECMB250/633 U

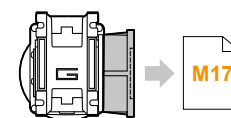
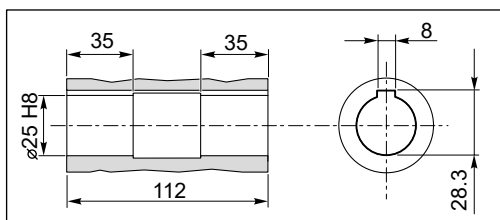
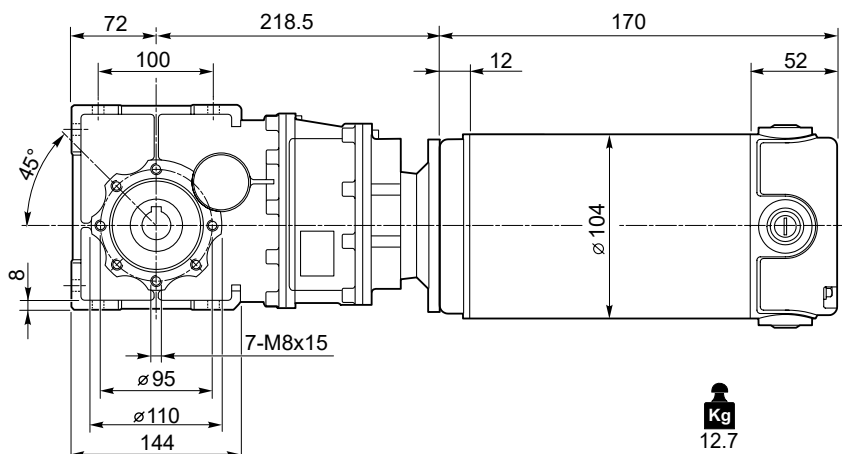

Motori / Motors IP66 → I8

ECMB350/402 U

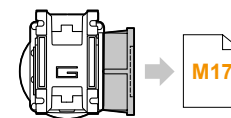
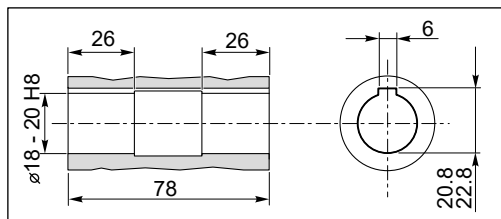
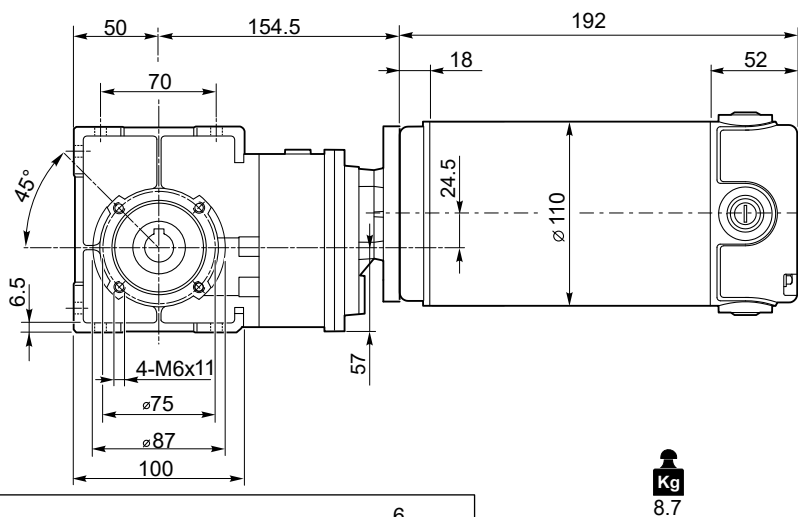

Freno / Brake → H23

Motori / Motors IP66 → I10

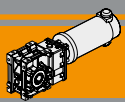

Dimensioni

Dimensions

ECMB350/502 U

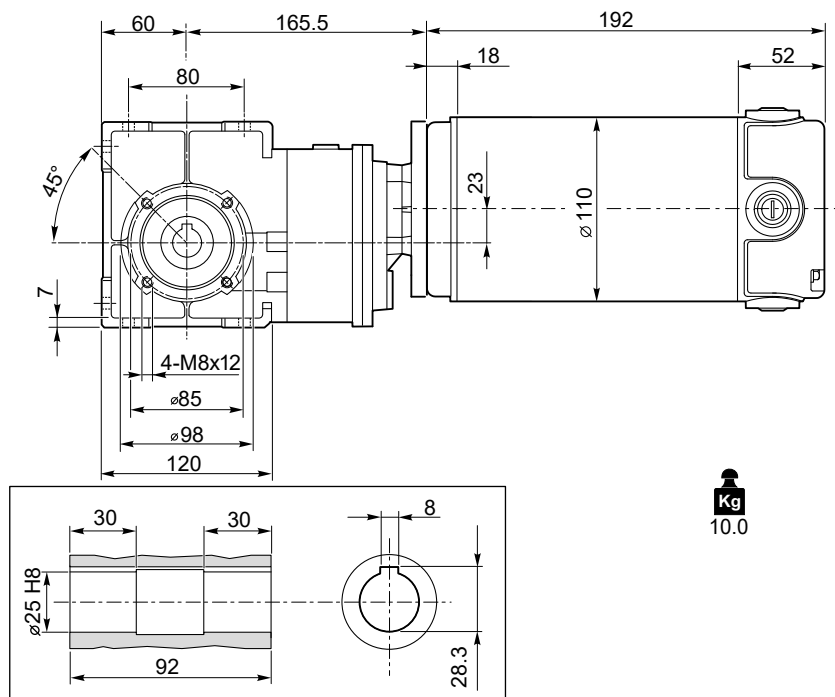

Kg
10.0

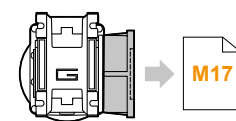
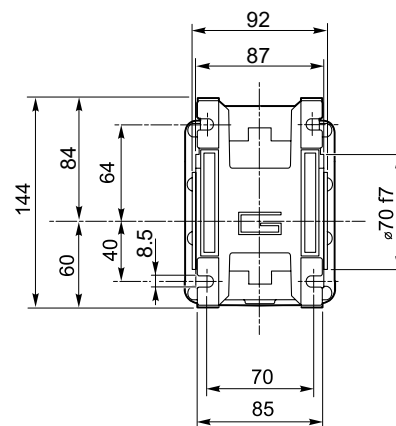

ECMB350/633 U

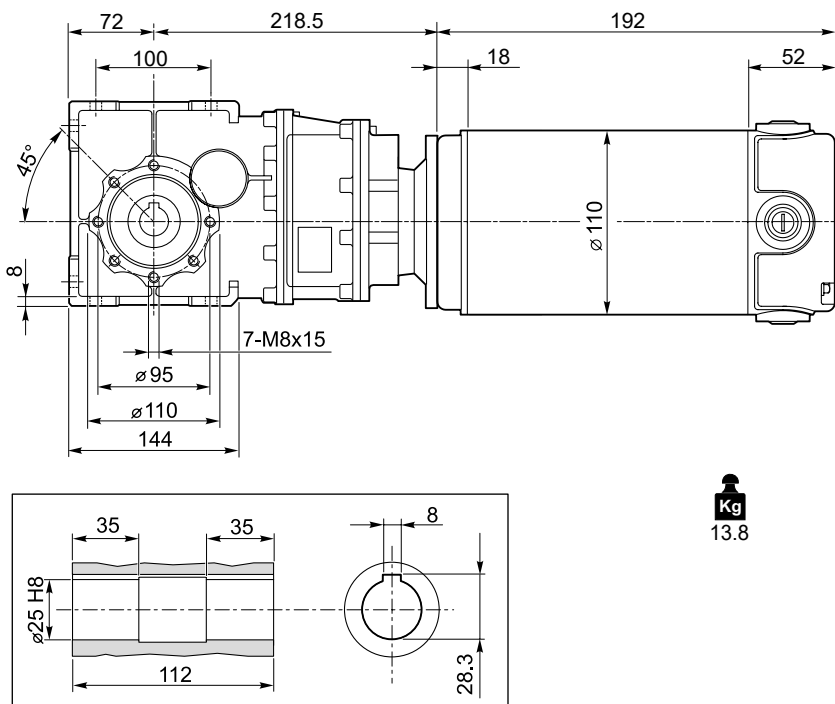

Kg
13.8

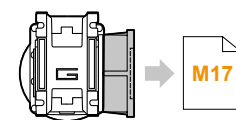
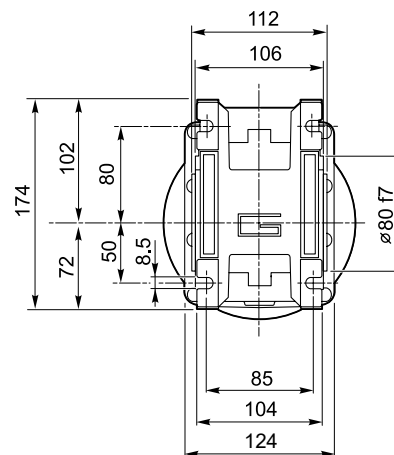

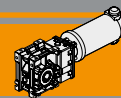

Dimensioni

Dimensions

ECMB350/903 U

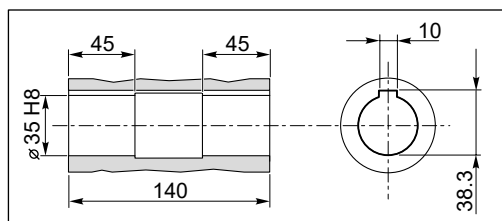
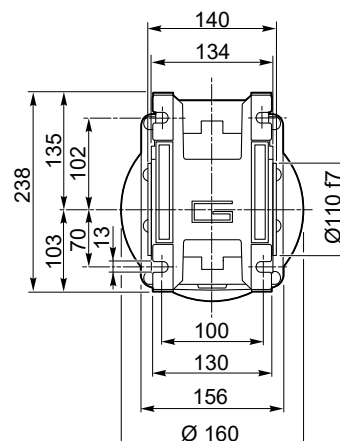
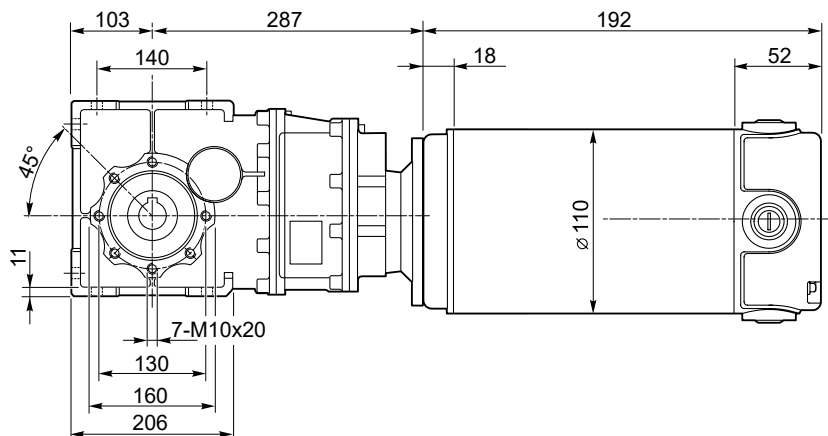

Kg
23.4

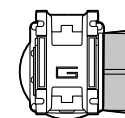

M17

Freno / Brake

H23

ECMB600/402 U

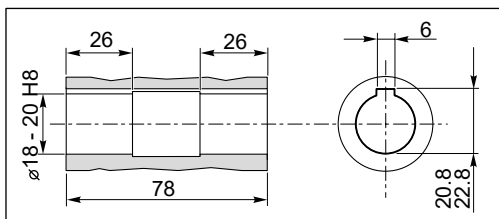
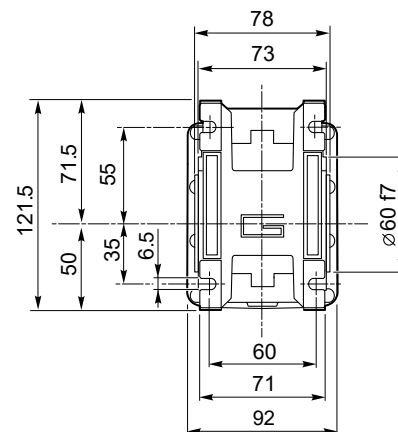
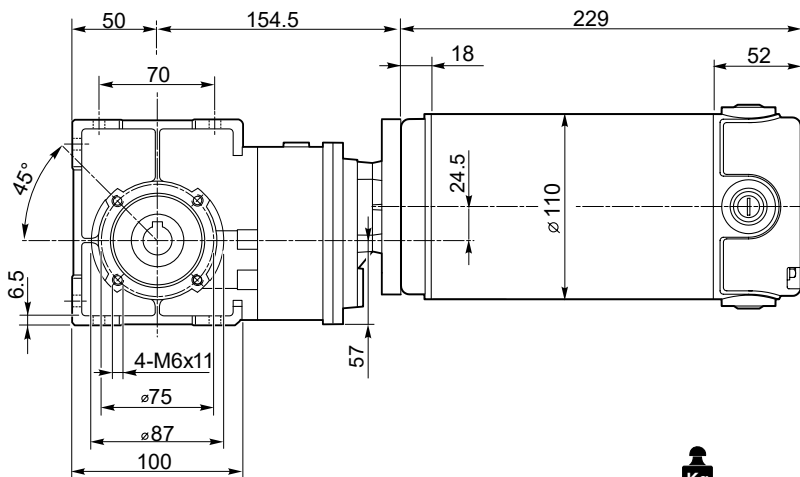

Kg
10.5

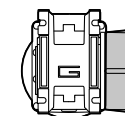

M17

Freno / Brake

H23

Motori / Motors IP66

I12

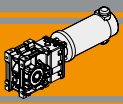

Dimensioni

Dimensions

ECMB600/502 U

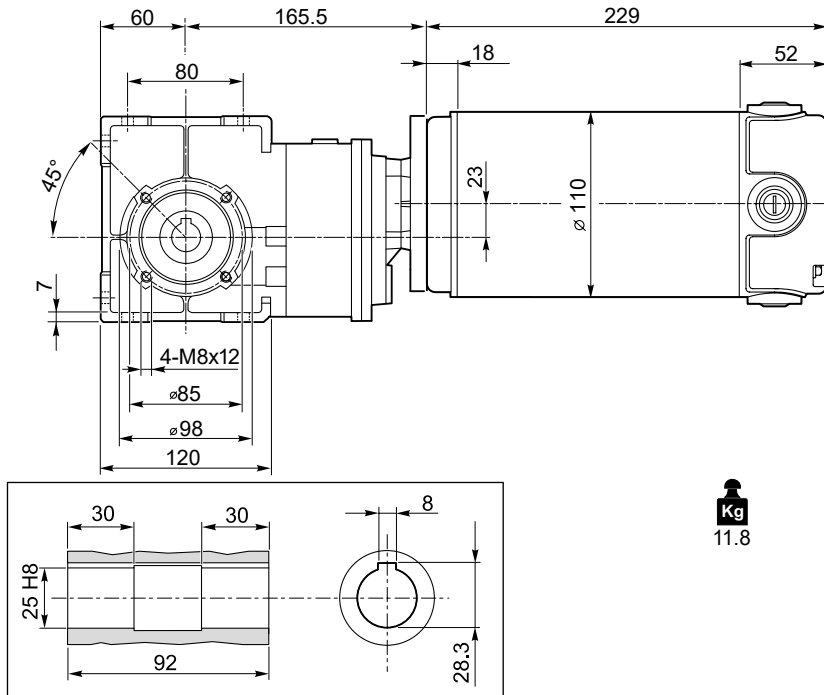

Kg
11.8

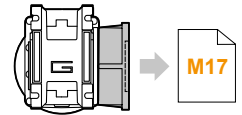
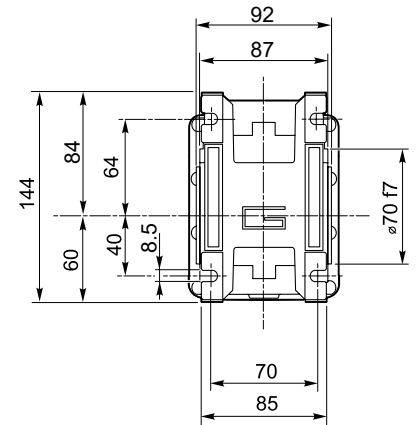

ECMB600/633 U

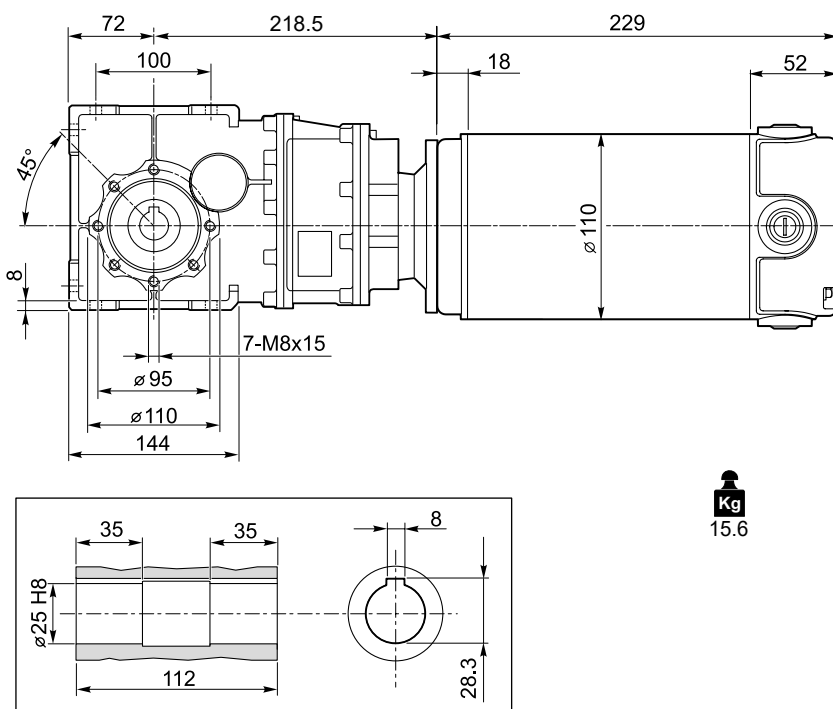

Kg
15.6

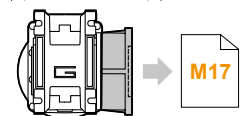
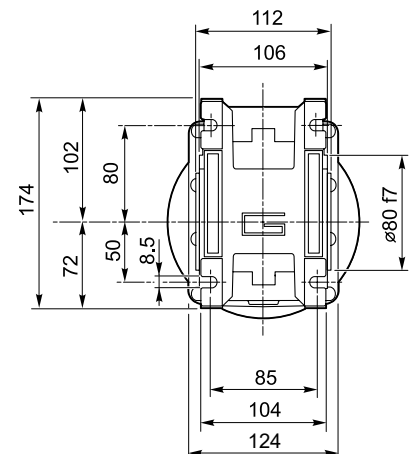

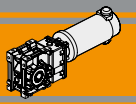

Dimensioni

Dimensions

ECMB600/903 U

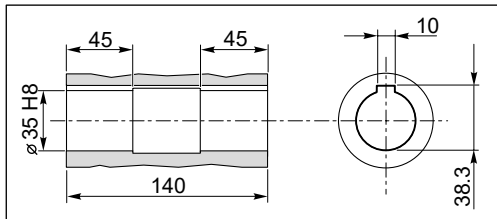
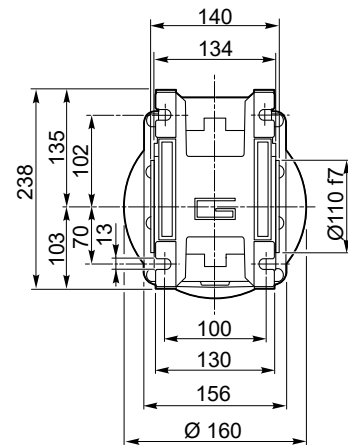
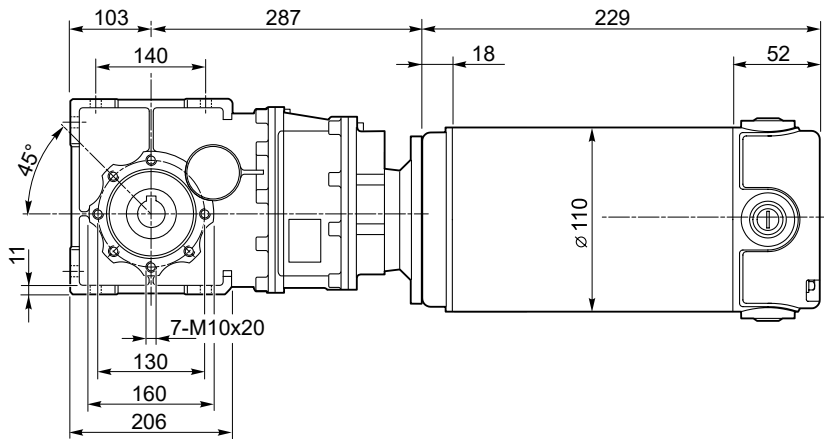

Kg
25.5

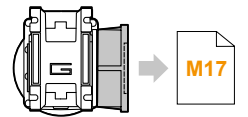

ECMB.../... F... Flange uscita / Output flanges

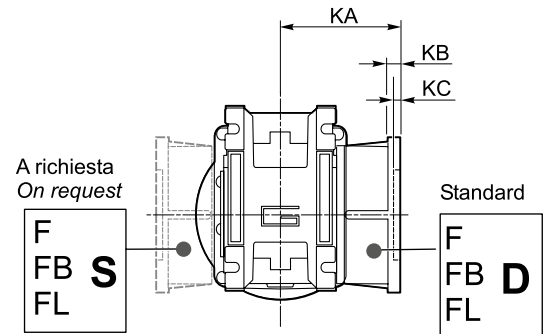
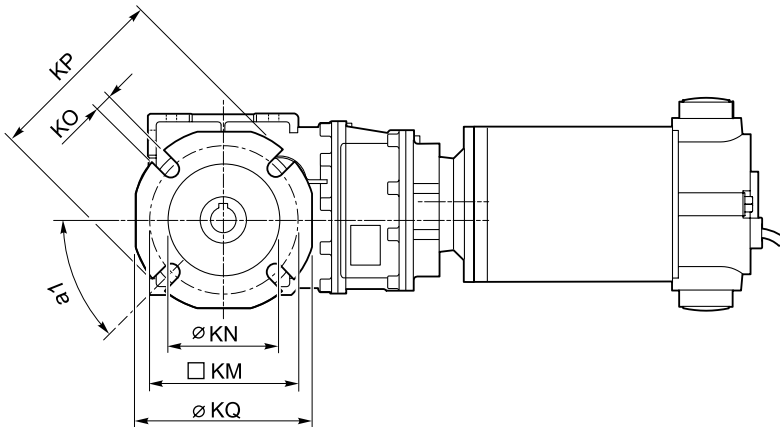

ECMB

CMB	Flange uscita / Output flanges																										
	F									FL									FB								
	a ₁	KA	KB	KC	KM	KN H8	KO	KP	KQ	a ₁	KA	KB	KC	KM	KN H8	KO	KP	KQ	a ₁	KA	KB	KC	KM	KN H8	KO	KP	KQ
402	45°	67	7.5	4.5	80-95	60	9	110	95	45°	97	7.5	4.5	80-95	60	9	110	95	45°	80	8.5	5	115-125	95	9.5	140	112
502	45°	90	9	5	90-110	70	11	125	110	45°	120	9	5	90-110	70	11	125	110	45°	89	9	5	130-145	110	9.5	160	132
633	45°	82	10	6	150 - 160	115	11	180	142	45°	112	10	8	150 - 160	115	11	180	142	45°	98	11	5	165	130	11	200	160
933	45°	111	13	6	175-188	152	14	210	200	-									-								

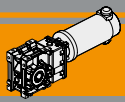

Accessori

Accessories

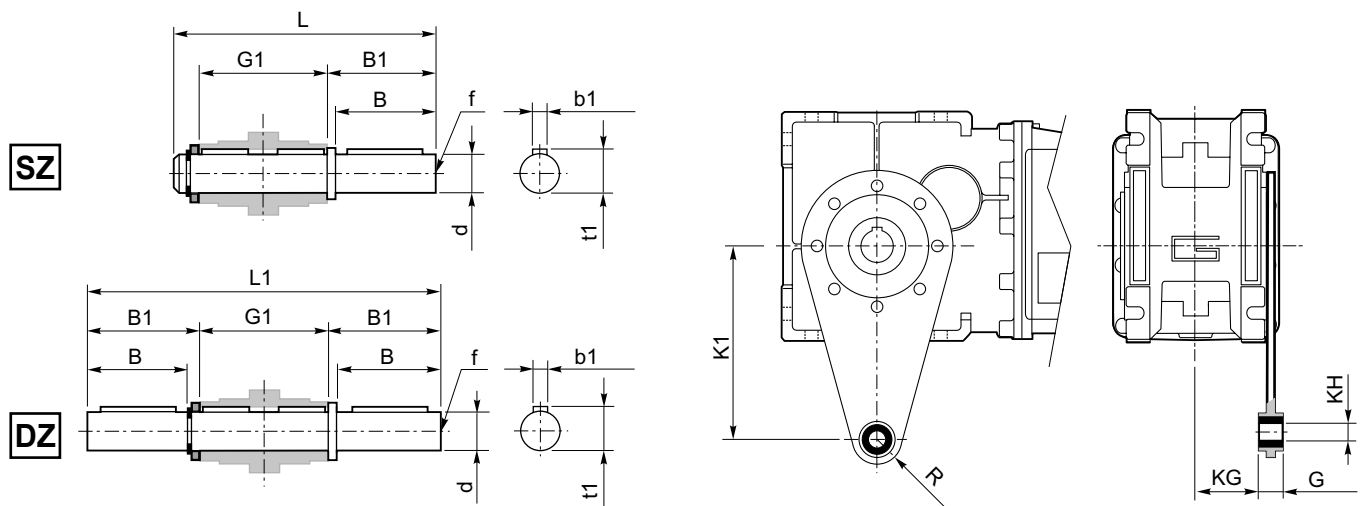

Albero lento / Output shaft

Braccio di reazione / Torque arm

CMB CMBIS	d h7	B	B1	G1	L	L1	f	b1	t1
402	18	40	43	78	128	164	M6	6	20.5
502	25	50	53.5	92	153	199	M10	8	28
633	25	50	53.5	112	173	219	M10	8	28
903	35	80	84.5	140	234	309	M12	10	38

CMB CMBIS	K1	G	KG	KH	R
402	100	14	31	10	18
502	100	14	38	10	18
633	150	14	47.5	10	18
903	200	25	56.5	20	30

SC - Safety cover

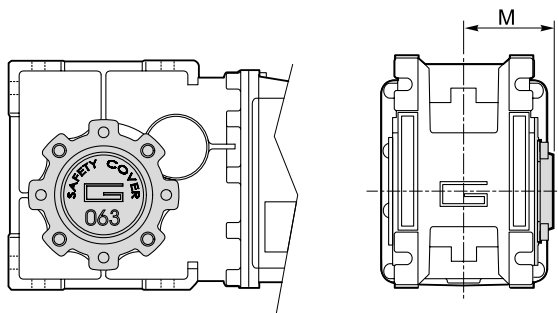

CMB CMBIS	M
402	54.5
502	62.5
633	73
903	94



MA TRANSTECNO S.A.P.I. DE C.V.
 Av. Mundial # 176, Parque Industrial
 JM Apodaca, Nuevo León,
 C.P. 66600
 MÉXICO
 T +52 8113340920
 info@transtecno.com.mx
 www.transtecno.com.mx



TRANSTECNO SRL
 Via Caduti di Sabbiano, 11/D-E
 40011 Anzola dell'Emilia (BO)
 ITALY
 T+39 051 64 25 811
 F +39 051 73 49 43
 sales@transtecno.com
 www.transtecno.com



**HANGZHOU TRANSTECNO POWER
 TRANSMISSIONS CO LTD**
 No.4 Xiuyan Road Fengdu Industry Zone
 Pingyao Town Yuhang District
 Hangzhou City, Zhejiang Province
 311115 – CHINA
 T +86 571 86 92 02 60
 F +86 571 86 92 18 10
 info-china@transtecno.com
 www.transtecno.cn



TRANSTECNO U.S.A. LLC
 5440 S.W. 156th Place Miami,
 FL 33185 - USA
 Tel: +1 (305) 220-4423
 Fax: +1 (305) 220-5945
 usaoffice@transtecno.com



TRANSTECNO B.V.
 Ind. terrein Wieken/Vinkenhof
 De Stuwdam,43
 3815 KM Amersfoort - NETHERLANDS
 Tel: +31(0) 33 45 19 505
 Fax: +31(0) 33 45 19 506
 info@transtecno.nl
 www.transtecno.nl



SALES OFFICE INDIA
 A/10, Anagha, S.N. Road, Mulund (W) Mumbai
 400080 - INDIA
 Tel: +91 9820614698
 Fax-Italy: +39 051 73 49 43
 indiaoffice@transtecno.com



SALES OFFICE BRAZIL
 Rua Dr. Freire Alemão 155 / 402 - CEP. 90450-060
 Auxiliadora Porto Alegre RS - BRAZIL
 Tel: +55 51 3251 5447
 Fax: +55 51 3251 5447
 Mobile: +55 51 811 45 962
 braziloffice@transtecno.com
 www.transtecno.com.br



TRANSTECNO AANDRIJFTECHNIEK B.V.
 De Stuwdam 43
 3815 KM Amersfoort - NETHERLANDS
 Tel: +31 (0) 33 20 4 7 006
 info@transtecnoaandrijftechnik.nl
 www.transtecnoaandrijftechnik.nl



SALES OFFICE SOUTH KOREA
 D-304 Songdo BRC Smart Valley 30, Songdomirae-ro,
 Yeonsu-gu, Incheon, 406-840 - KOREA
 Tel: +82 70 8288 2107
 Fax: +82 32 815 2107
 Mobile: +82 10 5094 2107
 koreaoffice@transtecno.com



**TRANSTECNO IBÉRICA
 THE MODULAR GEARMOTOR, S.A.**
 C/Enginy, 2 Nave 6 - 08850 Gavà (Barcelona) - SPAIN
 Tel: +34 931 598 950
 info@transtecno.es
 www.transtecno.es



SALES OFFICE OCEANIA
 44 Northview drive, Sunshine west 3020
 Victoria - AUSTRALIA
 Ph +61 03 9312 4722
 Fax +61 03 9312 4714
 Mobile: +61 0438060997
 oceaniaoffice@transtecno.com
 www.transtecno.com.au



SALES OFFICE FRANCE
 Tel: +33 (0) 6 85 12 09 87
 Fax-Italy: +39 051 73 49 43
 franceoffice@transtecno.com
 www.transtecno.fr

TRANSTECNO[®]
 the modular gearmotor
 www.transtecno.com