

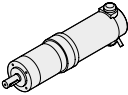

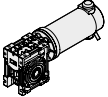



Micro Motoriduttori
Micro Gearmotors

	Indice	Index	Pag. Page
	A Motori CC a magneti permanenti	Permanent magnets DC motors	A1
	B Micro motoriduttori CC epicicloidali	DC Micro planetary gearmotors	B1
	C Micro motoriduttori CC a vite senza fine	DC Micro wormgearmotors	C1
	D Micro motoriduttori AC a vite senza fine	AC Micro wormgearmotors	D1
 ENERGY	E Motori brushless CC	Bushless DC motors	E1
 ENERGY	F Micro motoriduttori brushless CC epicicloidali	Micro brushless DC planetary gearmotors	F1
 ENERGY	G Micro motoriduttori brushless CC a vite senza fine	Micro brushless DC wormgearmotors	G1
	H Azionamenti per motori CC e brushless CC	DC and brushless DC motor control	H1
	I Micro encoder ME22	ME22 Micro encoder	I1

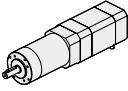
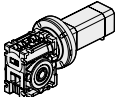
Questo catalogo annulla e sostituisce ogni precedente edizione o revisione. Ci riserviamo inoltre il diritto di apportare modifiche senza preavviso.

This catalogue supersedes any previous edition and revision. We reserve the right to implement modifications without notice.

Motori CC a magneti permanenti Permanent magnets DC motors

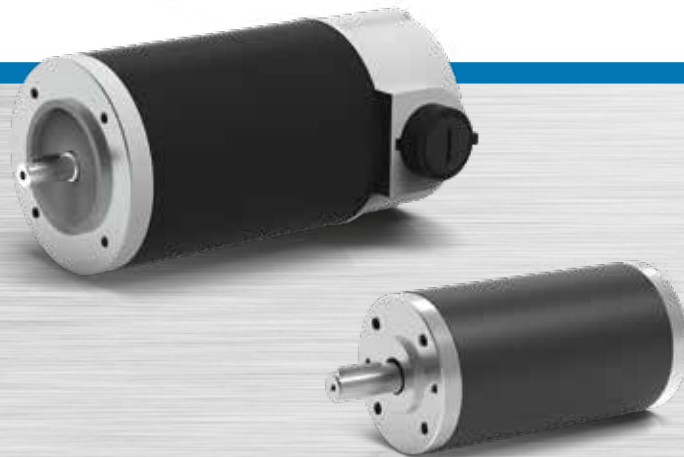

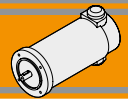

	Indice	Index	Pag. Page
	Caratteristiche tecniche	<i>Technical features</i>	A2
	Grado di protezione IP	<i>IP enclosures protection indexes</i>	A3
	Classe di isolamento termico	<i>Insulation class</i>	A3
EC020.120	Caratteristiche	<i>Features</i>	A4
EC020.24E	Dimensioni	<i>Dimensions</i>	A4
	Prestazioni	<i>Performances</i>	A5
EC030.240	Caratteristiche	<i>Features</i>	A6
EC030.24E	Dimensioni	<i>Dimensions</i>	A6
	Prestazioni	<i>Performances</i>	A7
EC035.120	Caratteristiche	<i>Features</i>	A8
EC035.240	Dimensioni	<i>Dimensions</i>	A8
	Prestazioni	<i>Performances</i>	A9
EC050.12E	Caratteristiche	<i>Features</i>	A10
EC050.24E	Dimensioni	<i>Dimensions</i>	A10
	Prestazioni	<i>Performances</i>	A11
EC070.12E	Caratteristiche	<i>Features</i>	A12
EC070.24E	Dimensioni	<i>Dimensions</i>	A12
	Prestazioni	<i>Performances</i>	A13
EC100.120	Caratteristiche	<i>Features</i>	A14
EC100.240	Dimensioni	<i>Dimensions</i>	A14
EC100.24E	Prestazioni	<i>Performances</i>	A15
EC180.120	Caratteristiche	<i>Features</i>	A16
EC180.240	Dimensioni	<i>Dimensions</i>	A16
EC180.24E	Prestazioni	<i>Performances</i>	A17
	Legenda / Glossario dei grafici	<i>Key / Diagram Glossary</i>	A18
	Dimensioni montaggio encoder	<i>Encoder assembling dimensions</i>	A19

Questa sezione annulla e sostituisce ogni precedente edizione o revisione. Qualora questa sezione non Vi sia giunta in distribuzione controllata, l'aggiornamento dei dati ivi contenuto non è assicurato. **In tal caso la versione più aggiornata è disponibile sul nostro sito internet www.intecno-srl.com**

This section replaces any previous edition and revision. If you obtained this catalogue other than through controlled distribution channels, the most up to date content is not guaranteed. In this case the latest version is available on our web site www.intecno-srl.com

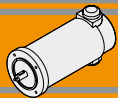

Caratteristiche tecniche

Le caratteristiche principali dei motori CC della serie EC a magneti permanenti in ferrite sono sono:

- Campo magnetico generato da magneti permanenti
- Costruzione tubolare, senza ventilazione
- Disponibili in 4 grandezze: diametro 42, 52, 65, 81 mm
- Alimentazione a bassa tensione, 12 o 24 Vcc
- Potenze disponibili da 30 a 250 W S2
- Elevate coppie di spunto
- Elevate coppie e potenze in dimensioni compatte

Classe di isolamento termico

Gli avvolgimenti del rotore sono soggetti a surriscaldamento, come pure altre parti del motore. Il grado di isolamento indica la massima temperatura ammissibile oltre la quale l'isolante della matassa e l'isolante di tutte le parti soggette ad elevato riscaldamento perdono le caratteristiche di buon isolante, con pericolo di danneggiamento del motore.

Servizio

Rappresenta la relazione tra il tempo di lavoro ed il tempo di riposo del motore. Servizio continuo (S1) = funzionamento continuo del motore a pieno carico.

Servizio intermittente (S2, S3, etc...) = periodi alternati di lavoro e di riposo tali da raffreddare il motore. Dato un motore, la potenza espressa per servizio continuo è inferiore a quella per servizio intermittente.

Fattore di forma

Indica quanta componente spuria alternata è presente nella alimentazione CC del motore. Più alto è il fattore ed inferiore è l'efficienza del motore. Alimentatori ad SCR = F.F 1.40. Alimentazione pura da batteria = FF 1. Alimentazione da transistori (modulazione PWM) = FF 1.05.

Qualitativamente l'andamento della coppia (percentuale) rispetto al fattore di forma è indicato nel grafico seguente:

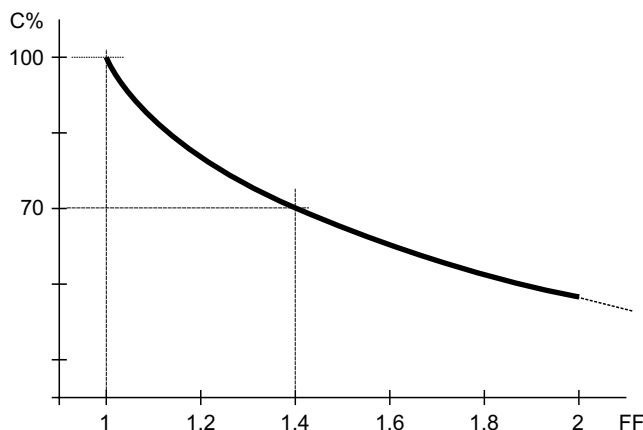

Technical features

The main features of EC ferrite permanent magnets DC motor range are:

- Magnetic field generated by permanent magnets
- Tubular construction, without fan
- Available in 4 sizes: diameter 42, 52, 65, 81 mm
- Low voltage power supply, 12 or 24 Vdc
- Power ratings available from 30 to 250 W S2
- High starting torque
- High torque and output power with compact package

Thermal insulation class

The windings of the rotor can overheat just like other parts of the motor too. The degree of insulation indicates the maximum allowable temperature above which the insulation of the windings, as well as that of all the parts which heat up to a high temperature, loses its insulating properties and the motor therefore risks being damaged.

Duty cycle

This represents the relationship between the time the motor operates and the time it remains stationary. Continuous operation (S1) = the motor operates non-stop under full load.

Intermittent operation (S2, S3, etc.) = alternating periods of work and rest so that the motor can cool down. The output power for continuous operation is lower than that for intermittent operation.

Form factor

It indicates how much spurious alternating current is present in the D.C. motor power supply. The higher the factor, the lower the motor's efficiency. SCR power supplies = F.F 1.40. Battery supply = FF 1 Transistor supply (PWM modulation) = FF 1.05.

The graph below indicates the torque trend (percentage) in relation to the form factor.

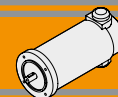

Grado di protezione IP

IP enclosures protection indexes

Indica il grado di isolamento meccanico del corpo motore.

Indicates the degree of mechanical insulation of the motor body.
1st figure indicating level of protection against the penetration of solid bodies.

1^a cifra protezione alla penetrazione di corpi solidi.

2^a cifra protezione contro la penetrazione d'acqua.

2nd figure: indicating degree to which the motor is waterproof.

0	Non protetto / No protection	0	Non protetto / No protection
1	Protetto da corpi solidi superiori a Ø 50 mm. <i>Protected against solid matters (over Ø 50 mm)</i>	1	Protetto contro la caduta verticale di gocce d'acqua. <i>Protected against drops of water falling vertically</i>
2	Protetto da corpi solidi superiori a Ø 12 mm. <i>Protected against solid matters (over Ø 12 mm)</i>	2	Protetto contro la caduta verticale di gocce d'acqua con inclinazione max di 15° <i>Protected against drops of water falling up to 15°</i>
3	Protetto da corpi solidi superiori a Ø 2,5 mm. <i>Protected against solid matters (over Ø 2,5 mm)</i>	3	Protetto contro la pioggia. <i>Rain proof fixture</i>
4	Protetto da corpi solidi superiori a Ø1 mm. <i>Protected against solid matters (over Ø1 mm)</i>	4	Protetto contro gli spruzzi. <i>Splash proof fixture</i>
5	Protetto contro la polvere <i>Dust proof</i>	5	Protetto contro getti d'acqua <i>Water jet proof</i>
6	Totalmente protetto contro la polvere <i>Fully dust proof</i>	6	Protetto dalle ondate <i>Wave proof</i>
7	N.A.	7	Protetto contro immersione <i>Watertight immersion fixture.</i>
8	N.A.	8	Protetto contro immersione/sommersione prolungata <i>Watertight immersion fixture for a long time.</i>

Classe di isolamento termico

Insulation class

Classe / Class	Δt °C Temp. ambiente: 40°C <i>Ambient temperature: 40°C</i>
A	65°C
B	90°C
F	115°C
H	140°C

Tipi di servizio IEC

IEC duty cycle ratings

S1	Servizio continuo. Funzionamento a carico costante per una durata sufficiente al raggiungimento dell' equilibrio termico.	Continuous duty. The motor works at a constant load for enough time to reach temperature equilibrium
S2	Servizio di durata limitata. Funzionamento a carico costante per una durata inferiore a quella necessaria al raggiungimento dell' equilibrio termico, seguito da un periodo di riposo tale da riportare il motore alla temperatura ambiente.	Short time duty. The motor works at a constant load, but not long enough to reach temperature equilibrium, and the rest periods are long enough for the motor to reach ambient temperature.
S3	Servizio periodico intermittente. Sequenze di cicli identici di marcia e di riposo a carico costante, senza raggiungimento dell' equilibrio termico. La corrente di spunto ha effetti trascurabili sul surriscaldamento del motore.	Intermittent periodic duty. Sequential, identical run and rest cycles with constant load. Temperature equilibrium is never reached. Starting current has little effect on temperature rise.
S4	Servizio periodico intermittente con avviamento. Sequenza di cicli di funzionamento identici di avviamento, marcia e riposo a carico costante, senza raggiungimento dell'equilibrio termico. La corrente di spunto ha effetti sul riscaldamento del motore.	Intermittent periodic duty with starting. Sequential identical start, run and rest cycles with constant load. Temperature equilibrium is not reached, but starting current affects temperature rise.
S5	Servizio periodico intermittente con frenatura elettrica. Sequenza di cicli di funzionamento identici di avviamento, marcia a carico costante, frenatura elettrica e riposo, senza raggiungimento dell'equilibrio termico.	Intermittent periodic duty with electric braking. Sequential, identical cycles of starting, running at constant load, electric braking and rest. Temperature equilibrium is not reached.
S6	Servizio periodico ininterrotto con carico intermittente. Sequenza di cicli di lavoro identici con carico costante e senza carico. Non ci sono periodi di riposo.	Continuous operation with intermittent load. Sequential, identical cycles of running with constant load and running with no load. No rest periods.
S7	Servizio periodico ininterrotto con frenatura elettrica. Sequenza di cicli di funzionamento identici di avviamento, marcia a carico costante e frenatura elettrica, senza periodi di riposo.	Continuous operation with electric braking. Sequential, identical cycles of starting, running at constant load and electric braking. No rest periods.
S8	Servizio periodico ininterrotto con variazioni di carico e di velocità. Sequenza di cicli identici di avviamento, marcia a carico costante e velocità definita, seguiti da marcia a carico costante differente e velocità differente dalla precedente. Non ci sono periodi di riposo.	Continuous operation with periodic changes in load and speed. Sequential, identical, duty cycles of start, run at constant load and given speed, then run at other constant loads and speeds. No rest periods.

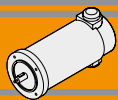

EC020.120 - EC020.24E

Caratteristiche

Features

Costruzione	Tubolare, senza ventilazione
Grandezza	Ø 42 mm
Potenza	30 W S2 (20 W S1)
Magneti	2
Supporti	Cuscinetti a sfera
Fori di montaggio	4
Alimentazione	Bassa tensione, 12 o 24 Vcc
Spazzole	N° 2 di composto grafite-rame
Cavo di alimentazione	Connettori faston (0.8 x 2.8 mm)
Opzioni	Filtro EMC
	Encoder

Construction	Tubular, without fan
Size	Ø 42 mm
Power	30 W S2 (20 W S1)
Magnets	2
Bearings	Ball bearing
Mounting holes	4
Power supply	Low voltage, 12 or 24 Vdc
Brushes	2 brushes made of graphite/copper composite
Electric cable	Faston terminals (0.8 x 2.8 mm)
Options	EMC filter
	Encoder

Tipo Type	S	Pn [W]	V [V]	I [A]	IC	FF	Mn [Nm]	n ₁ [min ⁻¹]	IP	Kg
EC020.120	S1	20	12	2.6	B	1	0.06	2850	20	0.4
	S2 6'	30		3.5			0.08			
EC020.24E	S1	20	24	1.4			0.06			
	S2 6'	30		1.9			0.08			

Azionamenti
Drives



Dimensioni

Dimensions

EC020.120

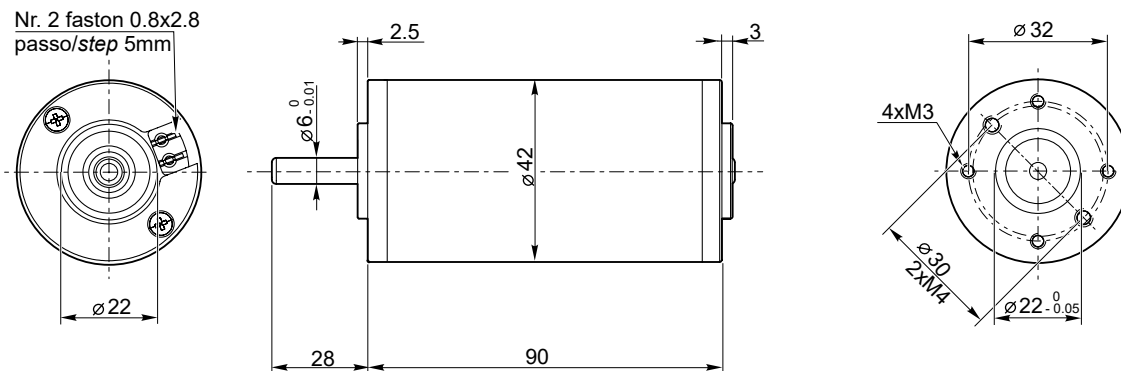

EC020.24E

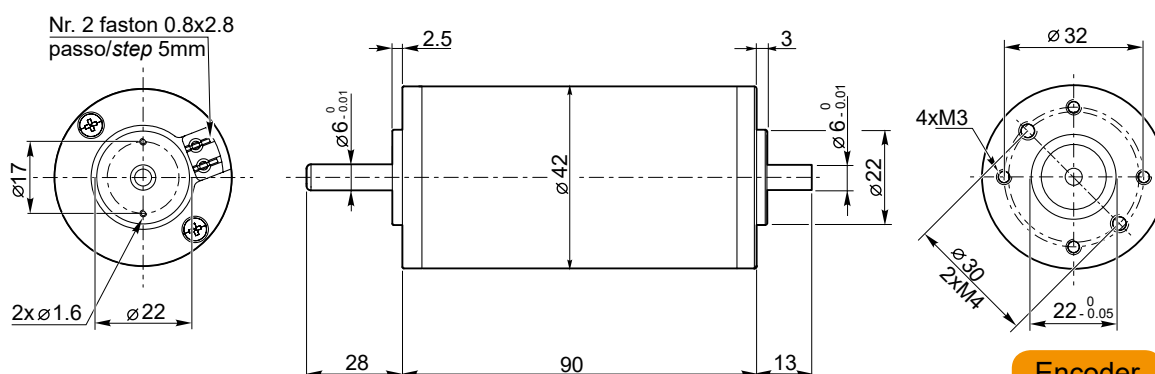

Encoder

12

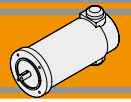

EC020.120 - EC020.24E

DC

EC

Prestazioni

Performances

EC020.120

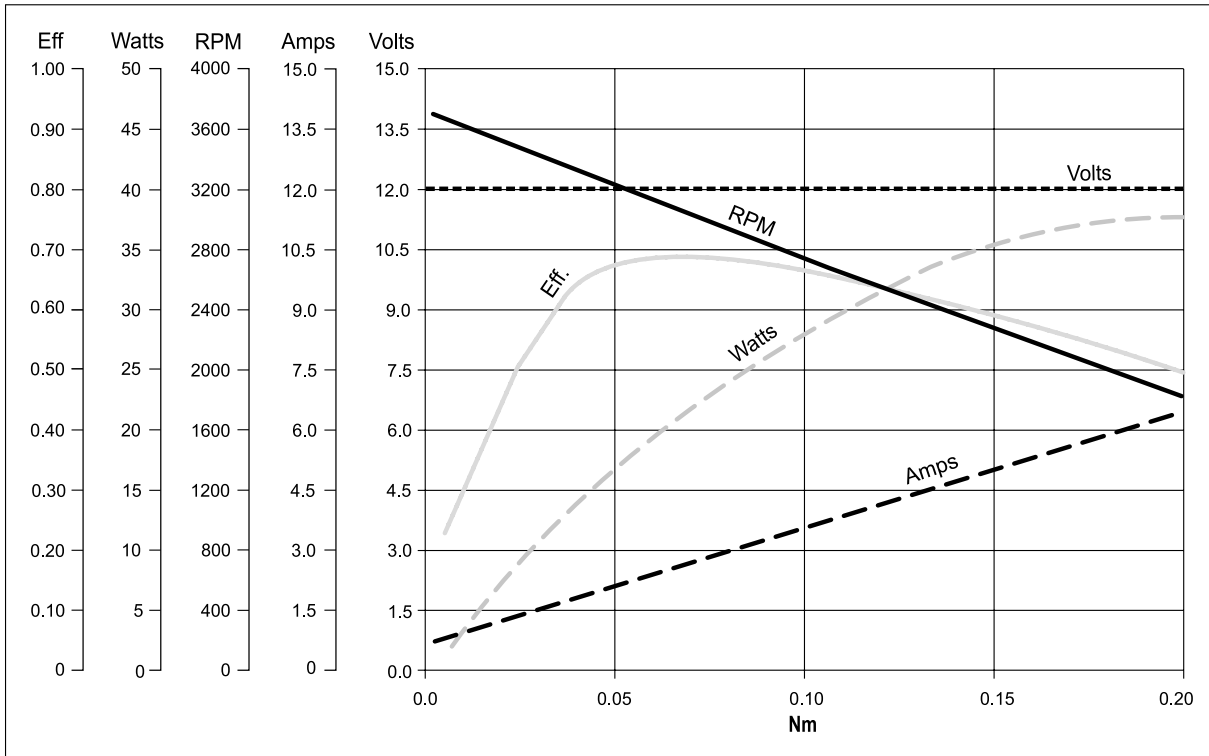

EC020.24E

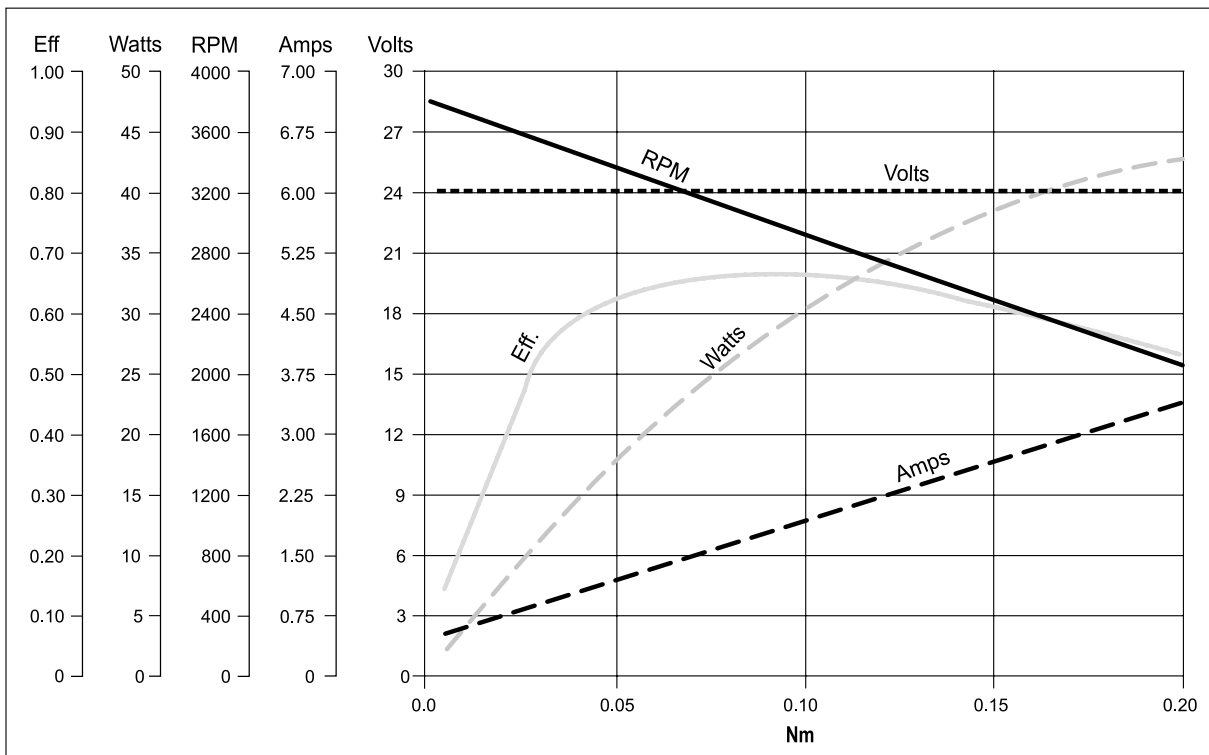

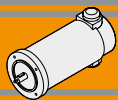

Motori CC a magneti permanenti Permanent magnets DC motors

EC030.240 - EC030.24E

Caratteristiche

Features

Costruzione	Tubolare, senza ventilazione
Grandezza	Ø 42 mm
Potenza	50 W S2 (30 W S1)
Magneti	2
Supporti	Cuscinetti a sfera
Fori di montaggio	6
Alimentazione	Bassa tensione, 12 o 24 Vcc
Spazzole	N° 2 di composto grafite-rame
Cavo di alimentazione	Connettori faston (0.8 x 2.8 mm)
Opzioni	Filtro EMC
	Encoder

Construction	Tubular, without fan
Size	Ø 42 mm
Power	50 W S2 (30 W S1)
Magnets	2
Bearings	Ball bearing
Mounting holes	6
Power supply	Low voltage, 12 or 24 Vdc
Brushes	2 brushes made of graphite/copper composite
Electric cable	Faston terminals (0.8 x 2.8 mm)
Options	EMC filter
	Encoder

Tipo Type	S	Pn [W]	V [V]	I [A]	IC	FF	Mn [Nm]	n ₁ [min ⁻¹]	IP	Kg
EC030.240	S1	30	24	2	B	1	0.10	3500	20	0.53
EC030.24E	S2 6'	50		3.5			0.16			

Azionamenti
Drives



Dimensioni

Dimensions

EC030.240

Nr. 2 faston 0.8x2.8
passo/step 5mm

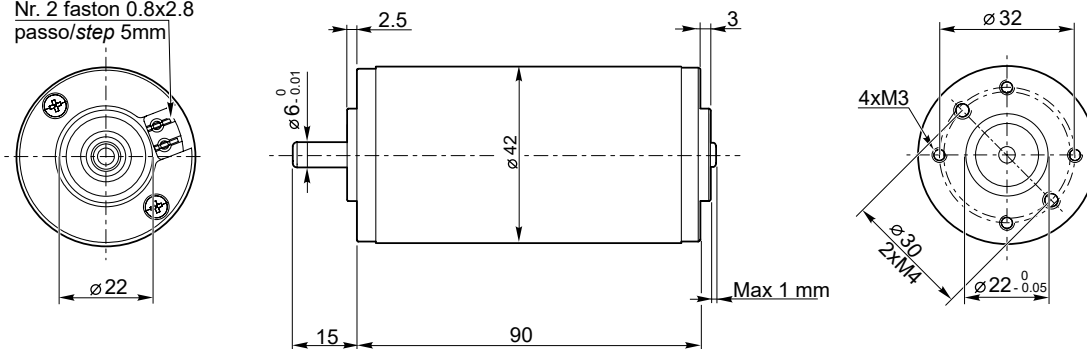

EC030.24E

Nr. 2 faston 0.8x2.8
passo/step 5mm

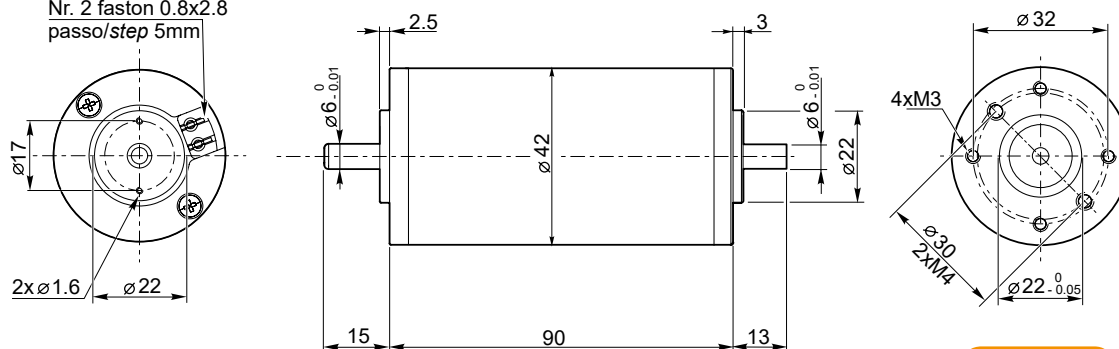

Encoder



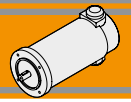

EC030.240 - EC030.24E

Prestazioni

Performances

DC

EC

EC030.240 - EC030.24E

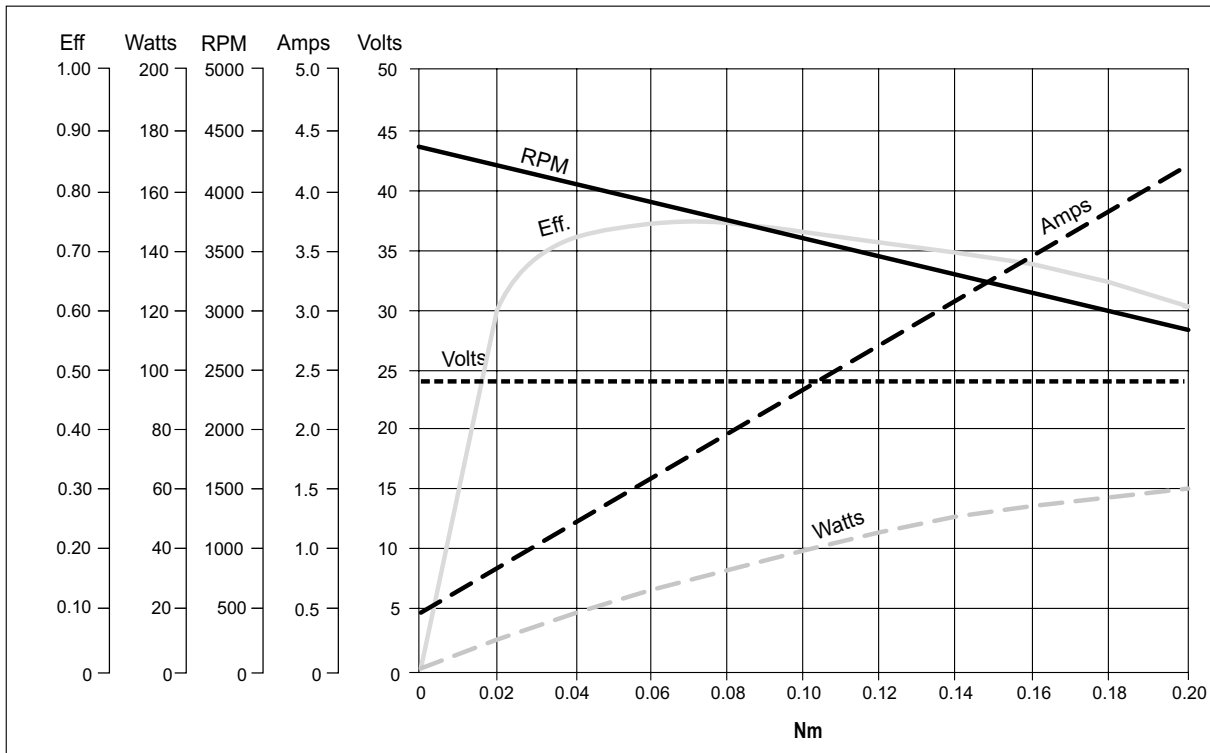

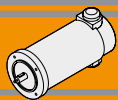

EC035.120 - EC035.240

Caratteristiche

Features

Costruzione	Tubolare, senza ventilazione
Grandezza	Ø 52 mm
Potenza	55 W S2 (35 W S1)
Magneti	2
Supporti	Cuscinetti a sfera
Fori di montaggio	4
Alimentazione	Bassa tensione, 12 o 24 Vcc
Spazzole	N° 2 interne di composto grafite-rame
Cavo di alimentazione	Lunghezza: 200 mm
Opzioni	Encoder

Construction	Tubular, without fan
Size	Ø 52 mm
Power	55 W S2 (35 W S1)
Magnets	2
Bearings	Ball bearings
Mounting holes	4
Power supply	Low voltage, 12 or 24 Vdc
Brushes	2 inside brushes made of graphite/copper composite
Electric cable	Length: 200 mm
Options	Encoder

Tipo Type	S	Pn [W]	V [V]	I [A]	IC	FF	Mn [Nm]	n ₁ [min ⁻¹]	IP	Kg
EC035.120	S1	35	12	5.2	F	1	0.11	3000	20	0.8
	S2 9'	55		8.0			0.18			
EC035.240	S1	35	24	2.6	F	1	0.11		20	0.8
	S2 9'	55		4.0			0.18			

Azionamenti
Drives



Dimensioni

Dimensions

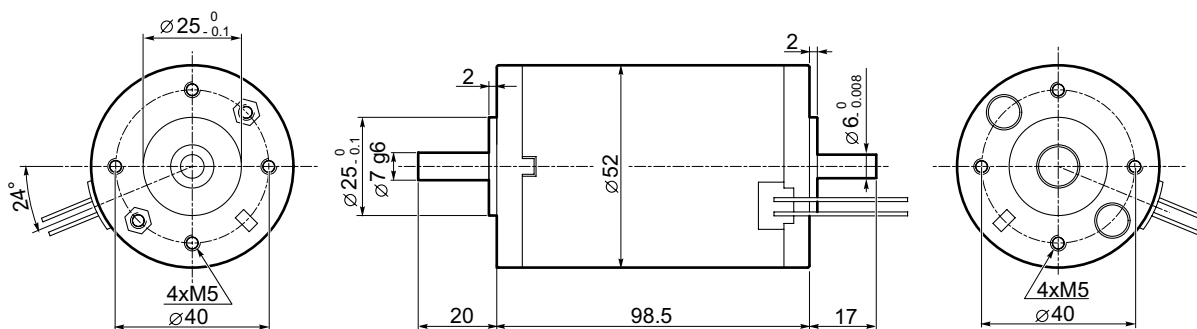

Encoder



Per montaggio encoder serve flangia AS 204
Encoder assembling needs flange AS 204

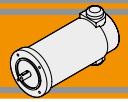

EC035.120 - EC035.240

Prestazioni

Performances

DC

EC

EC035.120

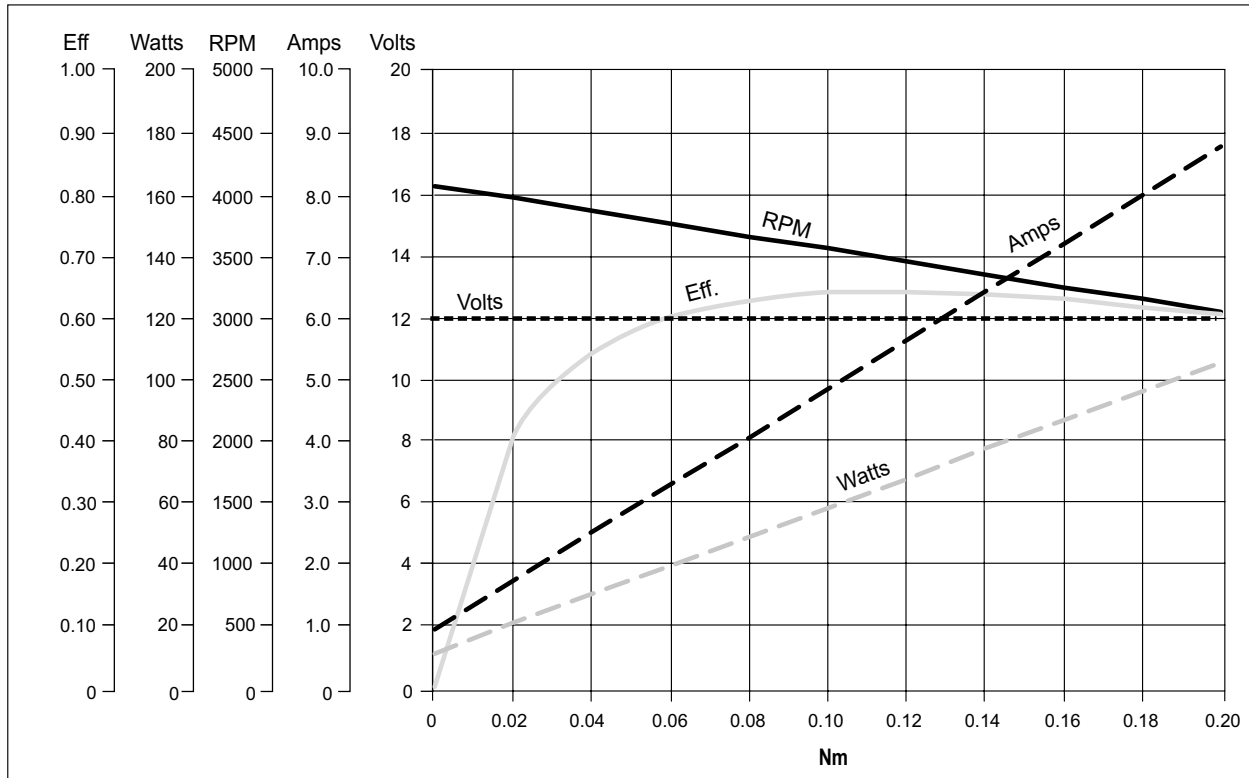

EC035.240

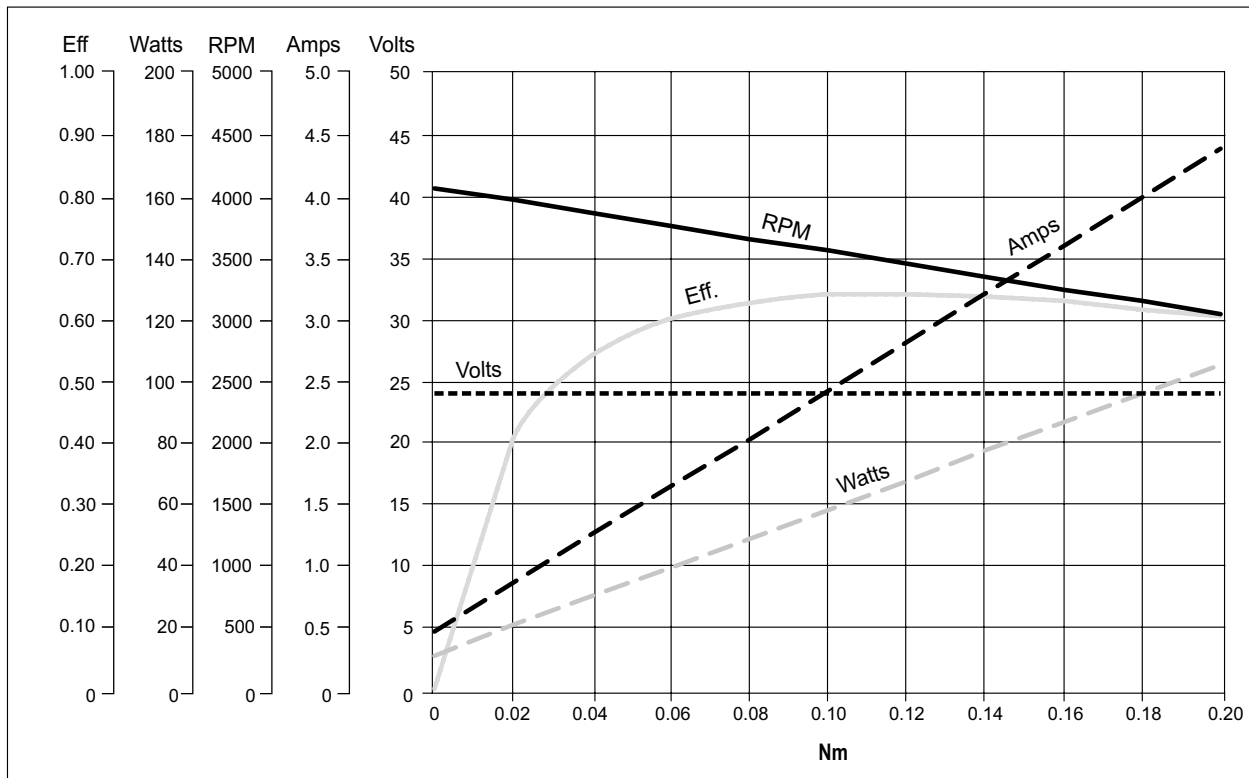

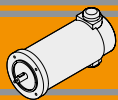

EC050.12E - EC050.24E

Caratteristiche

Features

Costruzione	Tubolare, senza ventilazione
Grandezza	Ø 65 mm
Potenza	70 W S2 (50 W S1)
Magneti	2
Supporti	Cuscinetti a sfera
Fori di montaggio	4
Alimentazione	Bassa tensione, 12 o 24 Vcc
Spazzole	N° 2 interne di composto grafite-rame
Cavo di alimentazione	Lunghezza: 200 mm
Bisporgenza	Standard

Construction	Tubular, without fan
Size	Ø 65 mm
Power	70 W S2 (50 W S1)
Magnets	2
Bearings	Ball bearings
Mounting holes	4
Power supply	Low voltage, 12 or 24 Vdc
Brushes	2 inside brushes made of graphite/copper composite
Electric cable	Length: 200 mm
Rear Shaft	Standard

Tipo Type	S	Pn [W]	V [V]	I [A]	IC	FF	Mn [Nm]	n ₁ [min ⁻¹]	IP	Kg
EC050.12E	S1	50	12	6.5	F	1	0.16	3000	20	1.2
	S2 15'	70		9.0			0.22			
EC050.24E	S1	50	24	3.2			0.16			
	S2 15'	70		4.5			0.22			



Dimensioni

Dimensions

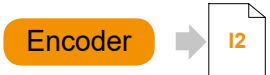
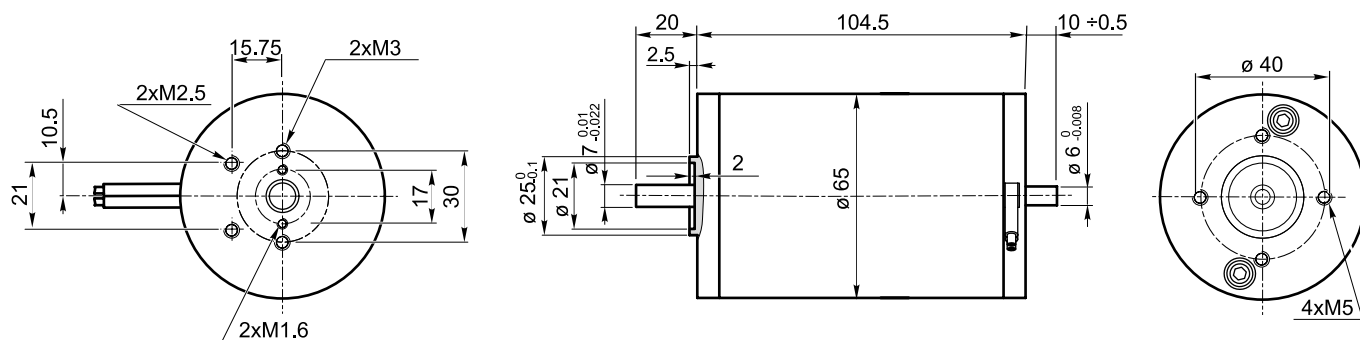

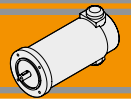

EC050.12E - EC050.24E

DC

EC

Prestazioni

Performances

EC050.12E

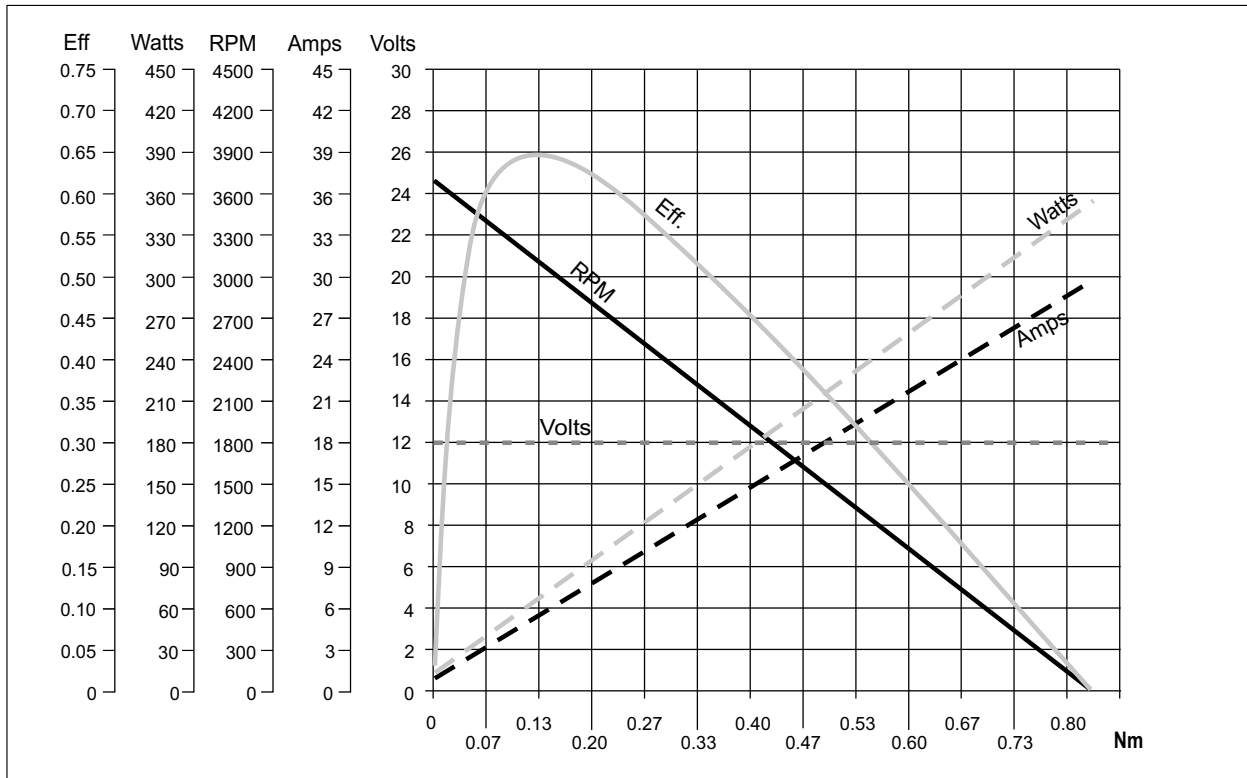

EC050.24E

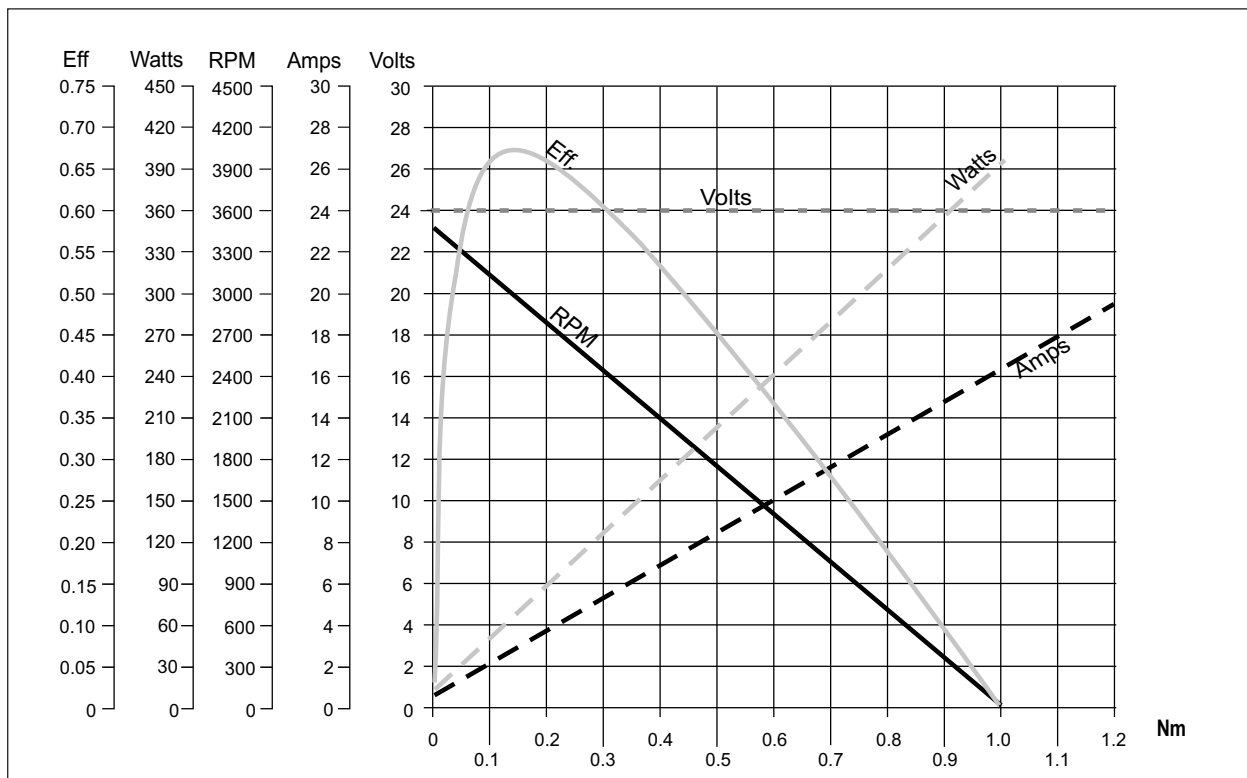

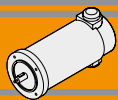

Motori CC a magneti permanenti Permanent magnets DC motors

EC070.12E - EC070.24E

Caratteristiche

Features

Costruzione	Tubolare, senza ventilazione
Grandezza	Ø 65 mm
Potenza	100 W S2
Magneti	2
Supporti	Cuscinetti a sfera
Fori di montaggio	4
Alimentazione	Bassa tensione, 12 o 24 Vcc
Spazzole	N° 2 interne di composto grafite-rame
Cavo di alimentazione	Lunghezza: 1000 mm

Construction	Tubular, without fan
Size	Ø 65 mm
Power	100 W S2
Magnets	2
Bearings	Ball bearings
Mounting holes	4
Power supply	Low voltage, 12 or 24 Vdc
Brushes	2 inside brushes made of graphite/copper composite
Electric cable	Length: 1000 mm

Tipo Type	S	Pn [W]	V [V]	I [A]	IC	FF	Mn [Nm]	n ₁ [min ⁻¹]	IP	Kg
EC070.12E	S1	70	12	8.4	F	1	0.22	3000	20	1.7
	S2 30'	100		11.8			0.31			
EC070.24E	S1	70	24	4.2			0.22			
	S2 30'	100		5.9			0.31			

Azionamenti
Drives



Dimensioni

Dimensions

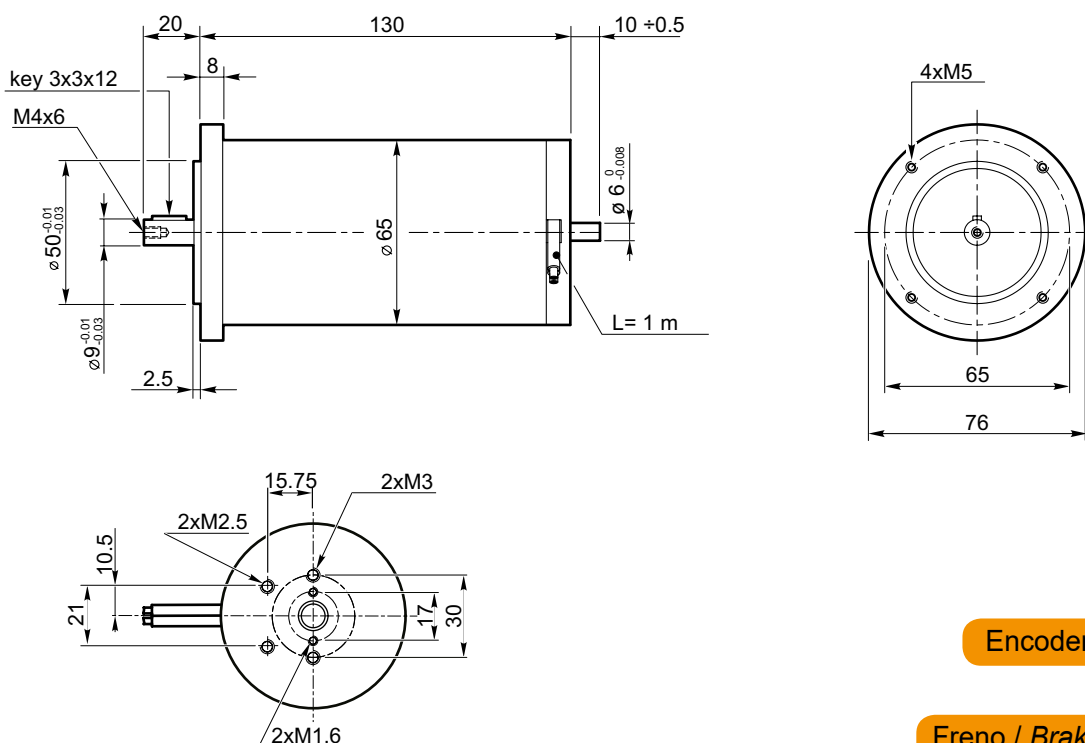

Encoder

I2

Freno / Brake

A20

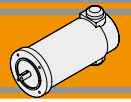

EC070.12E - EC070.24E

Prestazioni

Performances

DC

EC

EC070.12E

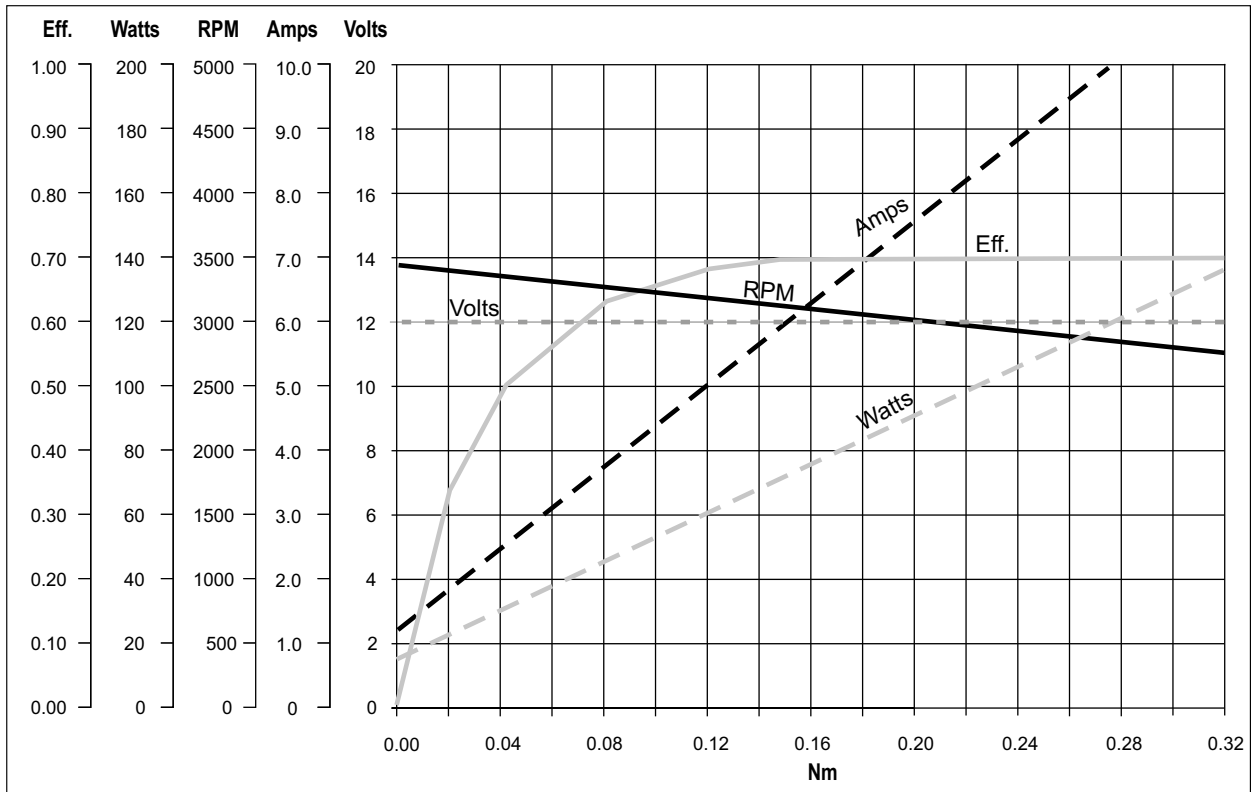

EC070.24E

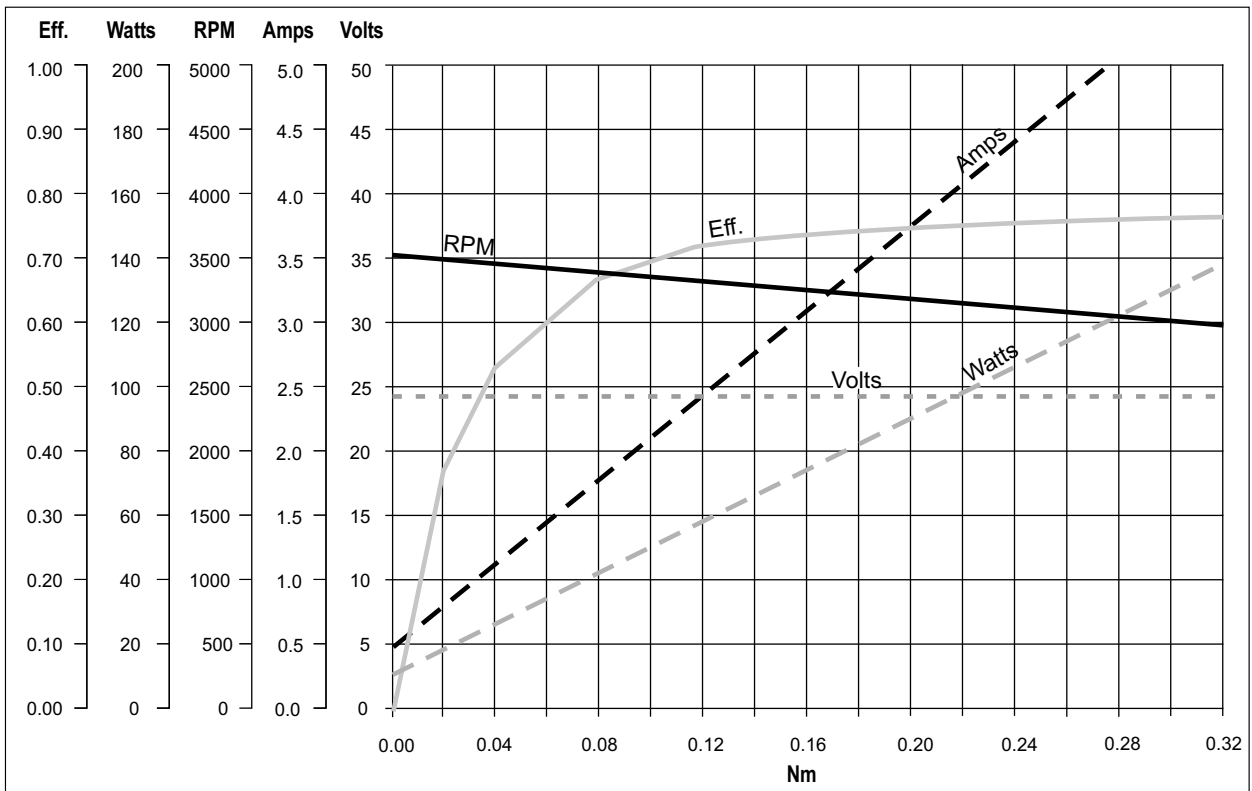

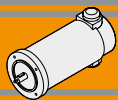

EC100.120 - EC100.240 - EC100.24E

Caratteristiche

Features

Costruzione	Tubolare, senza ventilazione
Grandezza	Ø 80 mm
Potenza	140 W S2 (100 W S1)
Magneti	2
Supporti	Cuscinetti a sfera
Fori di montaggio	4
Alimentazione	Bassa tensione, 12 o 24 Vcc
Spazzole	N° 2 di composto grafite-rame
Dimensione spazzole	LxPxH = 17.1 x 6.5 x 16.7 mm
Cavo di alimentazione	Lunghezza: 1000 mm
Bisporgenza	Standard solo EC100.24E

Construction	Tubular, without fan
Size	Ø 80 mm
Power	140 W S2 (100 W S1)
Magnets	2
Bearings	Ball bearings
Mounting holes	4
Power supply	Low voltage, 12 or 24 Vdc
Brushes	2 inside brushes made of graphite/copper composite
Brushes size	LxWxH = 17.1 x 6.5 x 16.7 mm
Electric cable	Length: 1000 mm
Rear shaft	Standard only EC100.24E

Tipo Type	S	Pn [W]	V [V]	I [A]	IC	FF	Mn [Nm]	n ₁ [min ⁻¹]	IP	Kg
EC100.120	S1	100	12	12	F	1	0.31	3000	40	2.7
	S2 25'	140		16.8			0.43			
EC100.240	S1	100	24	6			0.31			
	S2 25'	140		8.4			0.43			
EC100.24E	S1	100		6			0.31		20	
	S2 25'	140		8.4			0.43			

Azionamenti
Drives

➔ H2

Dimensioni

Dimensions

**EC100.120
EC100.240**

56 B14	
L	153
D	80
S	65
C (-0.03 / -0.01)	50
63B14*	
L	155
D	90
S	75
C (-0.03 / -0.01)	60

* Usare boccia 9/11
* Use sleeve 9/11

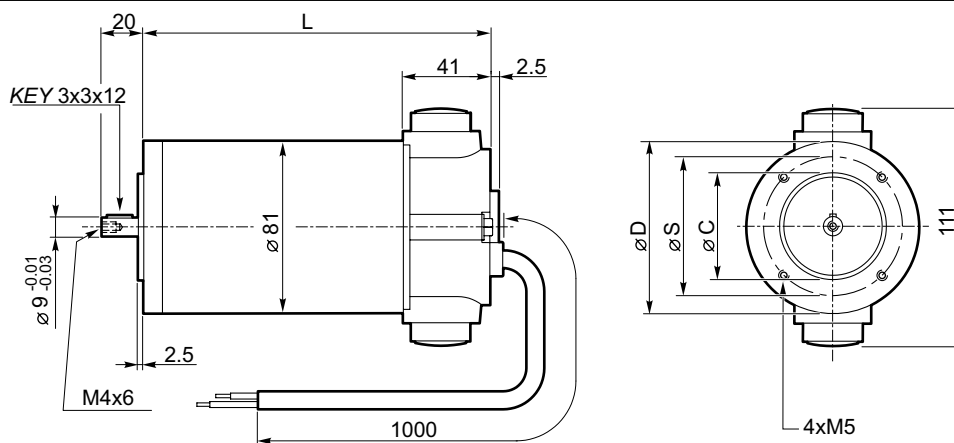

EC100.24E

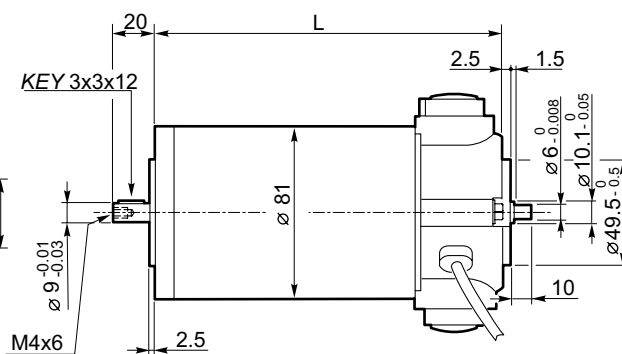
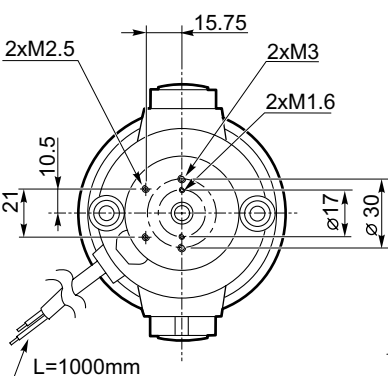

Encoder ➔ I2

Freno / Brake ➔ A20

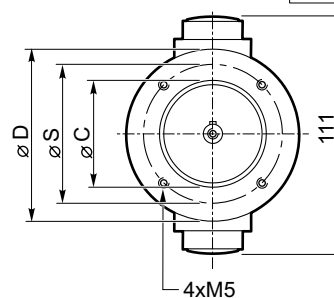

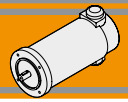

EC100.120 - EC100.240 - EC100.24E

Prestazioni

Performances

DC

EC

EC100.120

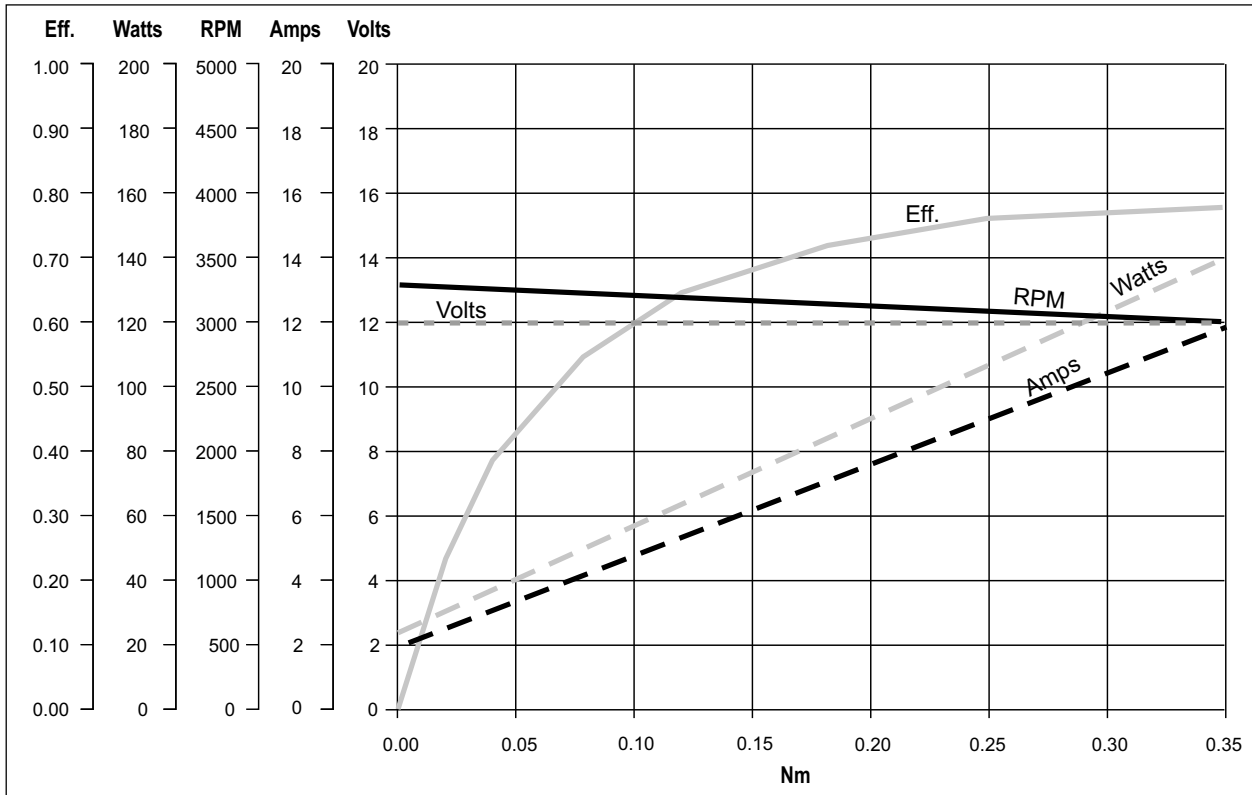

EC100.240 - EC100.24E

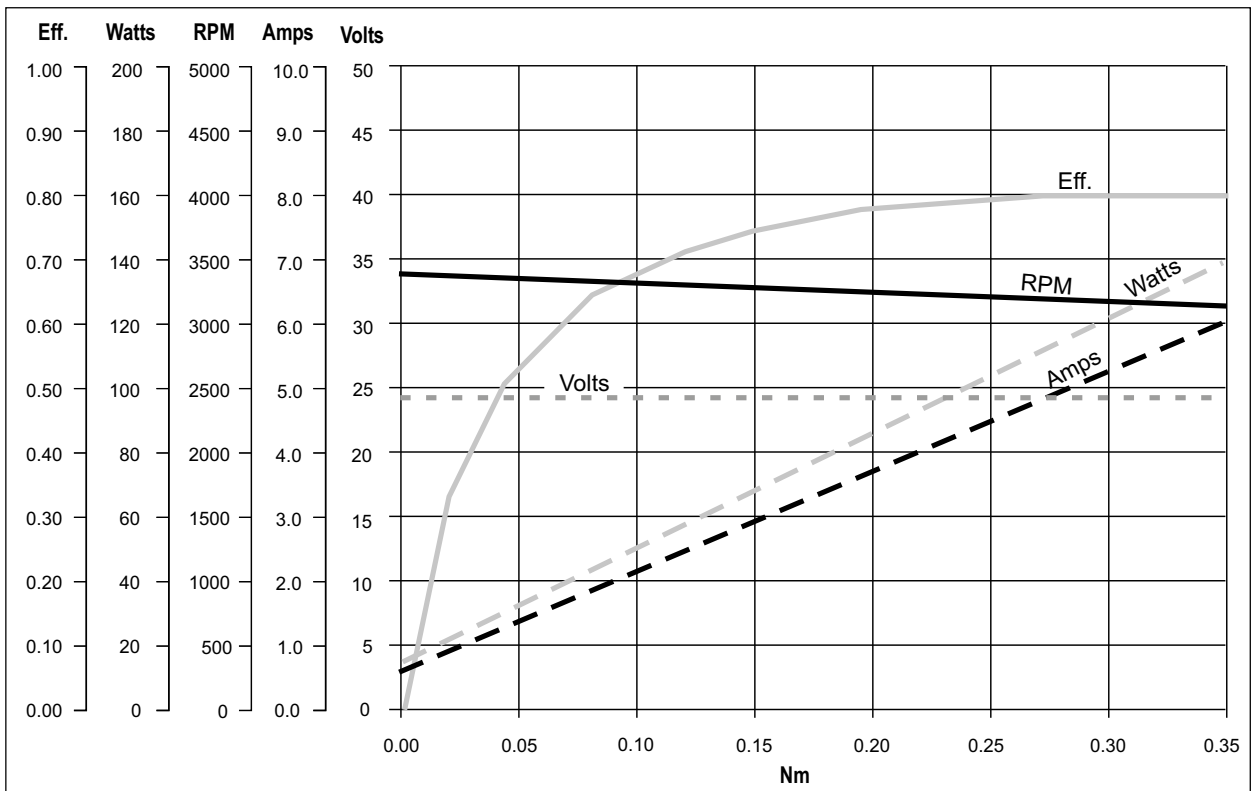

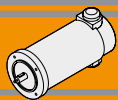

EC180.120 - EC180.240 - EC180.24E

Caratteristiche

Features

Costruzione	Tubolare, senza ventilazione
Grandezza	Ø 80 mm
Potenza	250 W S2 (180 W S1)
Magneti	2
Supporti	Cuscinetti a sfera
Fori di montaggio	4
Alimentazione	Bassa tensione, 12 o 24 Vcc
Spazzole	N° 2 di composto grafite-rame
Dimensione spazzole	LxPxH = 17.1 x 6.5 x 16.7 mm
Cavo di alimentazione	Lunghezza:1000 mm
Bisporgenza	Standard solo EC180.24E

Construction	Tubular, without fan
Size	Ø 80 mm
Power	250 W S2 (180 W S1)
Magnets	2
Bearings	Ball bearings
Mounting holes	4
Power supply	Low voltage, 12 or 24 Vdc
Brushes	2 inside brushes made of graphite/copper composite
Brushes size	LxPxH = 17.1 x 6.5 x 16.7 mm
Electric cable	Length: 1000 mm
Rear shaft	Standard only EC180.24E

Tipo Type	S	Pn [W]	V [V]	I [A]	IC	FF	Mn [Nm]	n ₁ [min ⁻¹]	IP	Kg	
EC180.120	S1	180	12	21.5	F	1	0.57	3000	40	3.4	
	S2 25'	250		30			0.8				
EC180.240	S1	180	24	10.8			0.57				20
	S2 25'	250		15			0.8				
EC180.24E	S1	180	24	10.8			0.57		20		
	S2 25'	250		15			0.8				

Azionamenti
Drives



Dimensioni

Dimensions

**EC180.120
EC180.240**

56 B14	
L	185
D	80
S	65
C (-0.03 / -0.01)	50
63B14*	
L	187
D	90
S	75
C (-0.03 / -0.01)	60

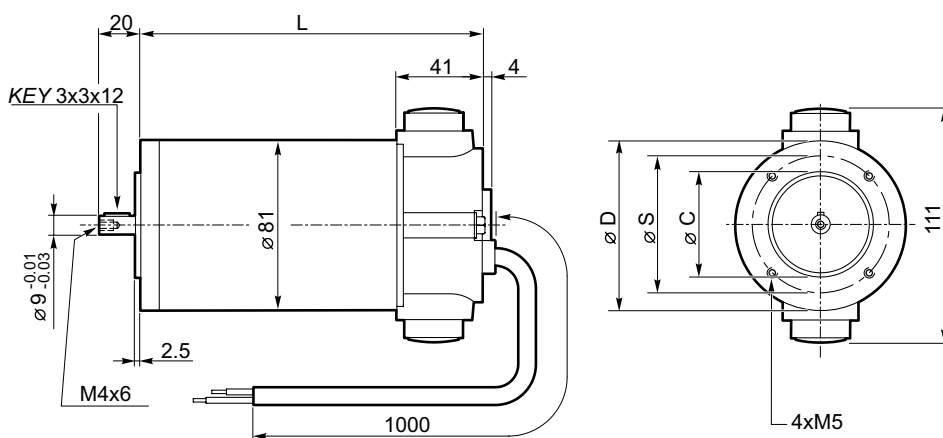

* Usare boccia 9/11
* Use sleeve 9/11

EC180.24E

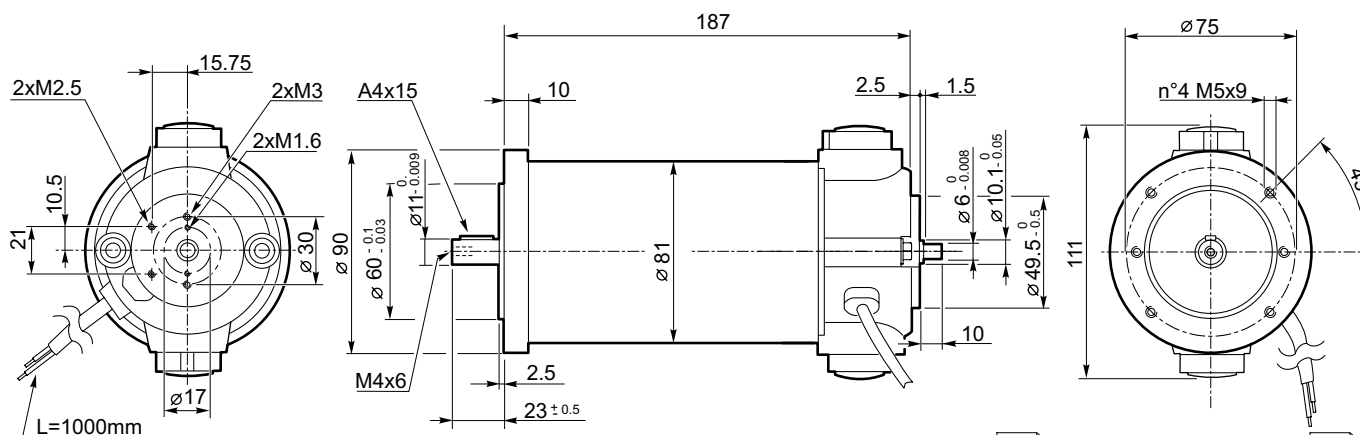

Freno / Brake



Encoder



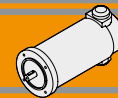

EC180.120 - EC180.240 - EC180.24E

Prestazioni

Performances

DC
EC

EC180.120

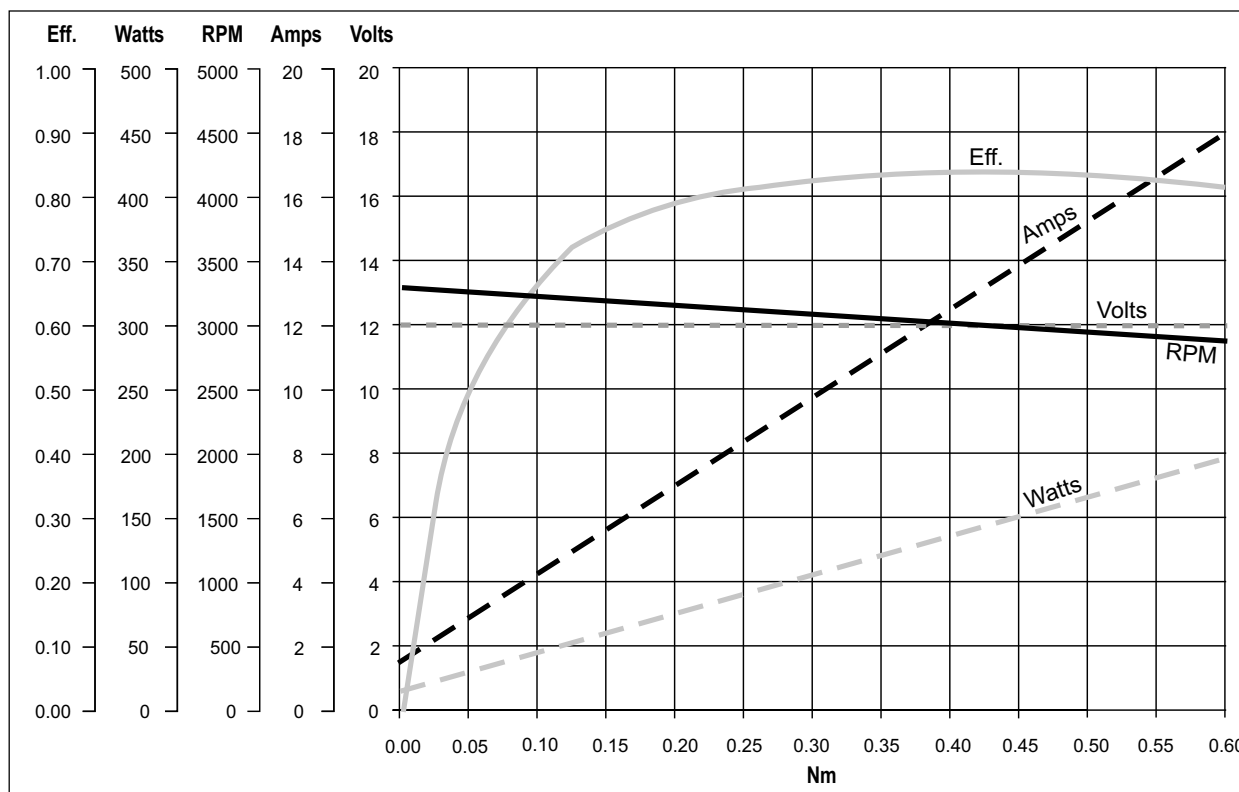

EC180.240 - EC180.24E

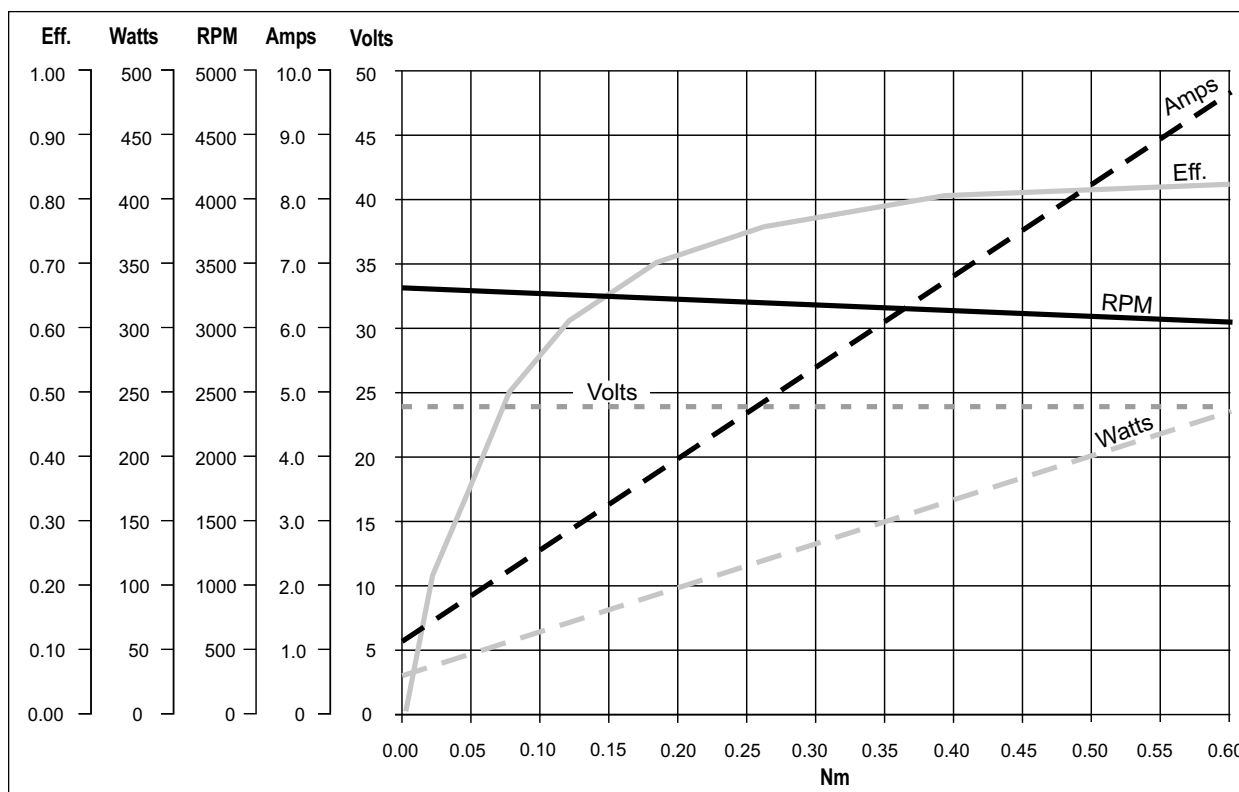

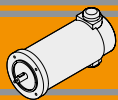

Legenda / Glossario dei grafici

Key / Diagram Glossary

Dato un motore in C.C., la velocità di rotazione è funzione lineare della coppia; così pure la corrente assorbita è una funzione lineare della coppia. Velocità e corrente variano in maniera sensibile al variare del carico.

With a D.C. motor, the rotational speed is a linear function of the torque. In the same way, the absorbed current is also a linear function of the torque. Speed and current change a lot against applied torque.

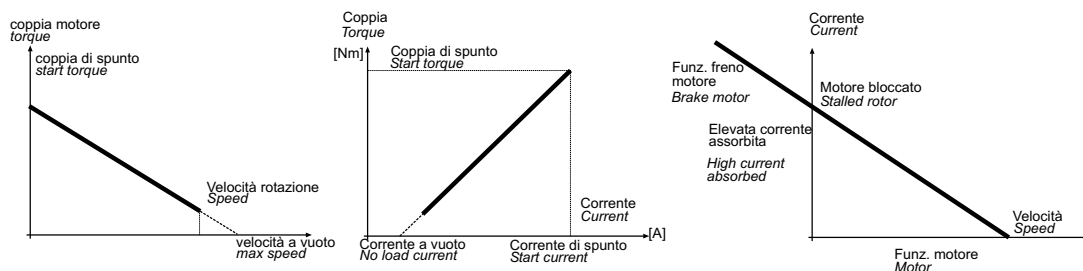

La potenza utile (potenza all' albero) si ricava dalla formula:

$$P_n [W] = M_n \cdot S = \frac{2\pi}{60} \cdot n_1 \cdot M_n$$

The output power is calculated using the formula:

$$P_n [W] = M_n \cdot S = \frac{2\pi}{60} \cdot n_1 \cdot M_n$$

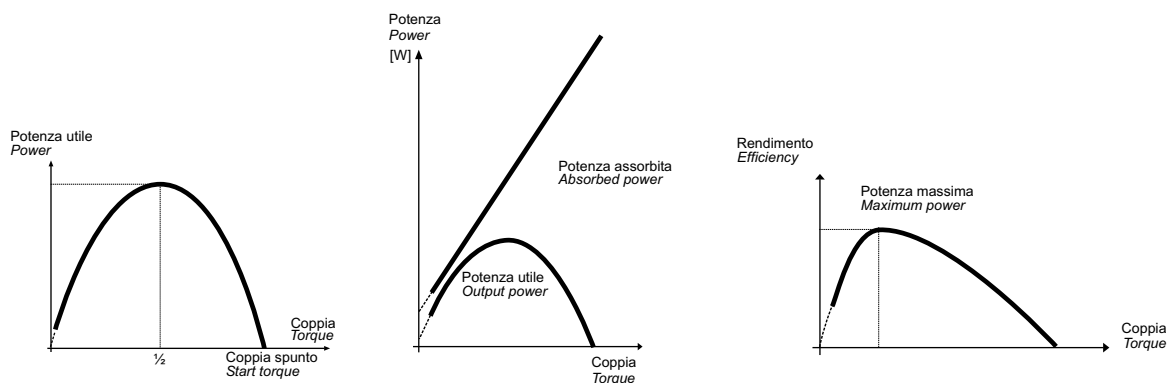

Poiché la tensione di alimentazione è costante mentre la corrente è linearmente crescente al crescere della coppia, l'andamento della potenza assorbita è un retta crescente. Dal rapporto tra la potenza meccanica e la potenza assorbita si ottiene il grafico dell'efficienza.

Since the supply voltage is constant, whereas the current increases in a linear manner as the torque increases, the absorbed power trend is a straight line going up. Efficiency is shown from the ratio between the output power and the absorbed power.

Formule utili

Useful formulas

$$\eta = \frac{P_n}{P_a}$$

$$P_a = V \cdot I$$

$$P_n = V \cdot I \cdot \eta$$

$$P_n = M_n \cdot S_v$$

$$S_v = \frac{n_1}{9.55}$$

$$\eta = \frac{P_n}{P_a}$$

$$P_a = V \cdot I$$

$$P_n = V \cdot I \cdot \eta$$

$$P_n = M_n \cdot S_v$$

$$S_v = \frac{n_1}{9.55}$$

$$[HP] \cdot 746 = [W]$$

Esempio 2 HP = circa 1500 W.

$$[HP] \cdot 746 = [W]$$

Example 2 HP = approx. 1500 W.

S	—	Servizio	<i>Duty</i>
P_n	[W]	Potenza in uscita	<i>Rated power</i>
P_a	[W]	Potenza assorbita	<i>Absorbed power</i>
M_n	[Nm]	Coppia nominale	<i>Rated torque</i>
V	[V]	Tensione	<i>Voltage</i>
I	[A]	Corrente assorbita	<i>Absorbed current</i>
n₁	[min ⁻¹]	Numero giri motore	<i>Motor speed</i>
S_v	[rad/s]	Velocità angolare	<i>Angular speed</i>
IC	—	Classe d'isolamento termico	<i>Thermal insulation class</i>
FF	—	Fattore di forma	<i>Form factor</i>
IP	—	Classe di protezione	<i>protection class</i>
η	—	Rendimento	<i>Efficiency</i>
Kg	—	Peso	<i>Weight</i>

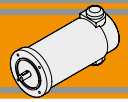

Dimensioni montaggio encoder

Encoder assembling dimensions

EC020.24E
EC030.24E

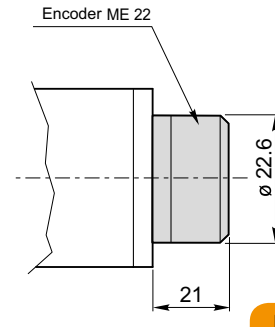
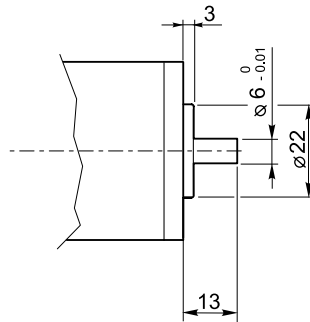
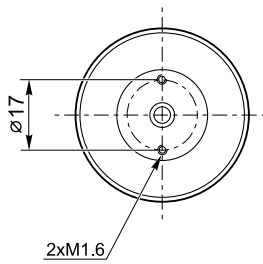

Encoder

I2

EC035.120
EC035.240

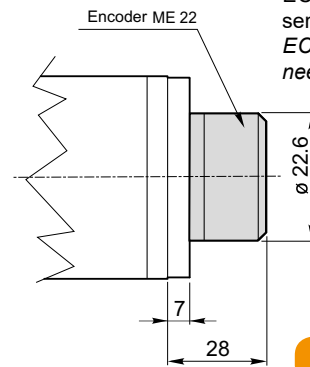
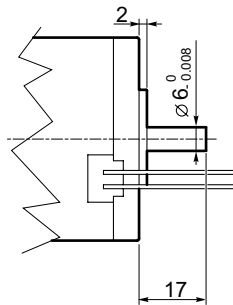
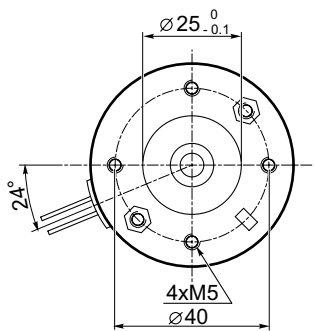

EC035: per montaggio encoder serve flangia AS204
EC035: encoder assembling needs flange AS204

Encoder

I2

EC050.12E
EC050.24E
EC070.12E
EC070.24E

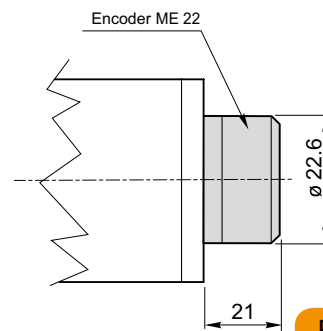
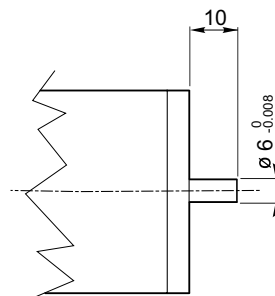
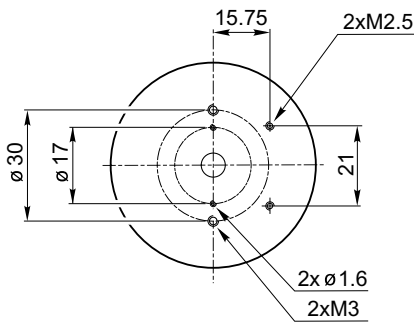

Encoder

I2

EC100.24E
EC180.24E

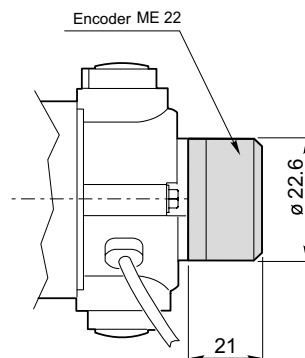
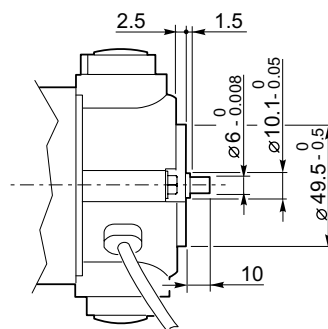
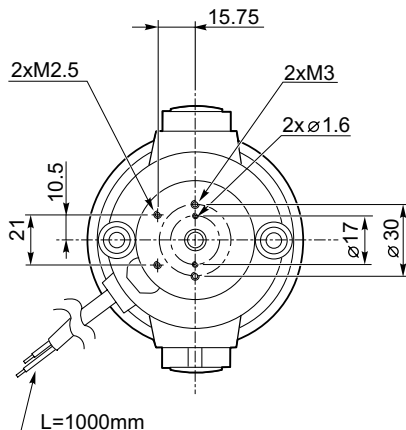

Encoder

I2

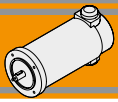

Freno

Brake

Freno / Brake

Freno con leva di sblocco/ Brake with hand release

EC050...BR
EC070...BR

EC050...BRL
EC070...BRL

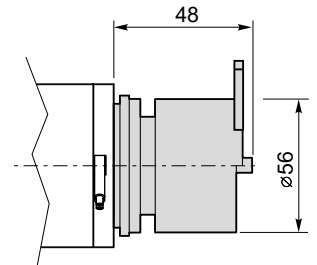
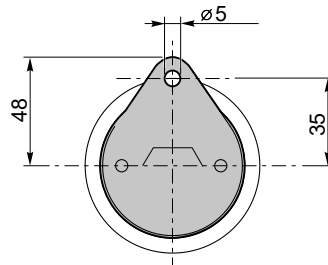
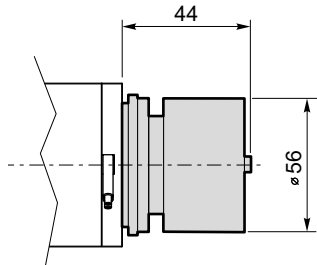

	P_n [W]	V [V]	M_n [Nm]	n₁ [min ⁻¹]
Caratteristiche del freno / Break features	14	12	2	3000
		24		

EC100.24E BR
EC180.24E BR

EC100.24E BRL
EC180.24E BRL

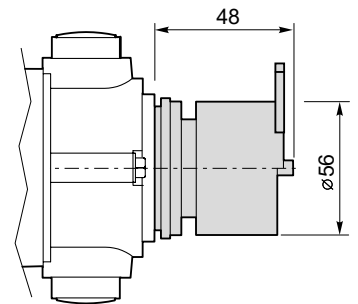
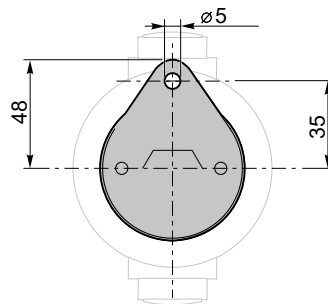
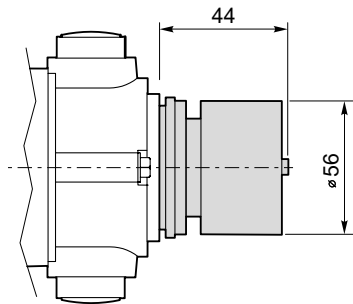

	P_n [W]	V [V]	M_n [Nm]	n₁ [min ⁻¹]
Caratteristiche del freno / Break features	14	12	2	3000
		24		

Micro motoriduttori CC epicicloidali DC Micro planetary gearmotors



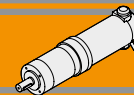

Indice	Index	Pag. Page
Caratteristiche tecniche	<i>Technical features</i>	B2
Designazione	<i>Classification</i>	B2
Simbologia	<i>Symbols</i>	B2
Lubrificazione	<i>Lubrication</i>	B2
Carichi radiali	<i>Radial loads</i>	B3
Rapporti	<i>Ratios</i>	B3
PK-P32 con motore CC	<i>PK-P32 with DC motor</i>	B4
PM32 LN con motore CC	<i>PM32 LN with DC motor</i>	B6
PK42 con motore CC	<i>PK42 with DC motor</i>	B8
P42 con motore CC	<i>P42 with DC motor</i>	B12
PK-P52 con motore CC	<i>PK-P52 with DC motor</i>	B16

Questa sezione annulla e sostituisce ogni precedente edizione o revisione. Qualora questa sezione non Vi sia giunta in distribuzione controllata, l'aggiornamento dei dati ivi contenuto non è assicurato. **In tal caso la versione più aggiornata è disponibile sul nostro sito internet www.intecno-srl.com**

*This section replaces any previous edition and revision. If you obtained this catalogue other than through controlled distribution channels, the most up to date content is not guaranteed. **In this case the latest version is available on our web site www.intecno-srl.com***

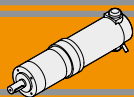

Caratteristiche tecniche

Technical features

Le caratteristiche principali dei motoriduttori CC epicycloidali della serie PK-P-PM LN sono:

- Alimentazione in bassa tensione 12/24 Vcc
- Possibilità di montaggio encoder
- Potenze motori disponibili da 8 a 250W S2
- Magneti permanenti in ferrite
- Lubrificazione permanente a grasso

Soluzione PK-SB:

- Completamente in plastica
- Bronzina su albero di uscita

Soluzione PK-BB:

- Mix plastica/metallo
- Doppio cuscinetto su albero di uscita

Soluzione P:

- Completamente in metallo
- Doppio cuscinetto su albero di uscita

Soluzione PM LN:

- Versione bassa rumorosità della versione P

The main features of DC planetary gearmotors range PK-P-PM LN are:

- Low voltage power supply 12/24 Vdc
- Suitable for encoder assembly
- Motor power ratings available from 8 up to 250W S2
- Ferrite permanent magnets
- Permanent grease long life lubrication

PK-SB solution:

- Completely made out of plastic
- Sintered bearing on output shaft

PK-BB solution:

- Plastic/metal mix
- Double ball bearing on output shaft

P solution:



- Completely made out of metal
- Double ball bearing on output shaft

PM LN solution:

- Low noise version of P solution

Designazione

Classification

RIDUTTORE / GEARBOX					MOTORE / MOTOR		
PK	42	2	46	BB	EC035	24V	—
Tipo Type	Grandezza Size	Stadi riduttore Gearbox stages	Rapporto in Ratio in	Versione Version	Tipo Type	Tensione Voltage	Opzioni Options
PK	32 42 52	1 2 3 4	Vedere tabelle See tables	SB BB	EC008 EC016 EC020 EC030 EC035 EC050 EC070 EC100 EC180	12V 24V	Encoder 
P				-			Freno / Brake 
PM	32			LN			

Simbologia

Symbols

Ns	n° stadi / No. stages	Pn	[W]	Potenza nominale / Nominal power
in	rapporto nominale / nominal ratio	V	[V]	Tensione / Voltage
ir	rapporto reale / real ratio	I	[A]	Assorbimento / Current
M _n	[Nm] coppia in uscita in funzionamento continuativo S1 output torque for continuous operation S1	IC		Classe di isolamento termico / Thermal insulation class
Rd	rendimento dinamico / efficiency	FF		Fattore di forma / Form factor
R ₂	[N] massimo carico radiale al centro dell'albero uscita max. radial load at output shaft centre	n ₁	[Rpm]	Giri / Speed
A ₂	[N] massimo carico assiale / max. axial load	IP		Grado di protezione / Enclosure protection
		Kg		Peso / Weight

Lubrificazione

Lubrication

I riduttori epicycloidali sono lubrificati in modo permanente, non richiedono quindi ulteriore manutenzione.

Questo gli consente di essere installati praticamente ovunque.

Temperatura ambiente 0 ÷ 40 °C (in assenza di congelamento ed in assenza di condensa).

Per temperature diverse, contattare nostro UT.

Planetary gearboxes are life-time lubricated with grease, therefore they are maintenance free.

They can be installed in any location.

Ambient temperature 0 ÷ 40 °C (in the absence of freezing and condensation).

For temperature outside this range please contact our technical dept.

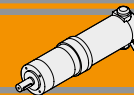

Carichi radiali

Radial loads

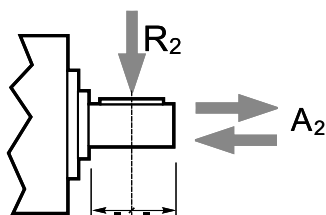

Ns	Carichi Radiali R ₂ [N] / Radial Load R ₂ [N]								
	PK32SB	PK32BB	P32	PM32LN	PK42SB	PK42BB	P42	PK52BB	P52
1	15	40	40	40	15	160	160	200	200
2	30	70	70	70	30	230	230	320	320
3	45	100	100	100	45	300	300	450	450
4	45	100	130	130	45	300	360	500	500

Ns	Carichi Assiali A ₂ [N] / Axial Load A ₂ [N]								
	PK32SB	PK32BB	P32	PM32LN	PK42SB	PK42BB	P42	PK52BB	P52
1	5	10	10	10	5	50	50	60	60
2	10	20	20	20	10	80	80	100	100
3	15	30	30	30	30	110	110	150	150
4	15	30	40	40	30	110	140	200	200

Rapporti

Ratios

PK SB BB / P 32 42 52		
Ns	in	ir
1	4	3.7
	4	4.28
	5	5.18
2	7	6.75
	14	13.73
	16	15.88
	18	18.36
	19	19.2
	22	22.2
	25	25.01
	27	26.85
	29	28.93
	35	34.97
3	46	45.56
	51	50.89
	59	58.85
	68	68.06
	71	71.16
	79	78.71
	93	92.7
	95	95.17
	100	99.5
	107	107.2
	115	115.07
	124	123.97
	130	129.62
	139	139.13
	150	149.9
169	168.84	
4	181	181.24
	195	195.26
	236	236.09
	308	307.54
4	a richiesta	on request

BASSA RUMOROSITA' / LOW NOISE PM 32 LN (*)		
Ns	in	ir
1	4	3.7
	4	4.28
	5	5.18
	7	6.75
2	14	13.73
	16	15.88
	18	18.36
	19	19.2
	22	22.2
	25	25.01
	27	26.85
	29	28.93
	35	34.97
	46	45.56
3	51	50.89
	59	58.85
	68	68.06
	71	71.16
	79	78.71
	93	92.7
	95	95.17
	100	99.5
	107	107.2
	115	115.07
	124	123.97
	130	129.62
	139	139.13
	150	149.9
	169	168.84
4	181	181.24
	195	195.26
	236	236.09
	308	307.54
4	369	368.76
	721	720.98

(*) PM42 LN e PM52 LN: disponibili a richiesta / on request

Rapporti preferenziali
Preferred ratios

Disponibile a 4 stadi con rapporti fino a 2076
Available 4 stages with ratio up to 2076

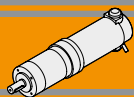

Micro motoriduttori CC epicicloidali DC Micro planetary gearmotors

PK-P32 con motore CC

PK-P32 with DC motor

PK32SB								EC008				EC016			
Ns	in	ir	M _n [Nm]	Rd	R ₂ [N]	A ₂ [N]	Kg	S1 12V		S1 24V		S1 12V		S1 24V	
								[Nm]	[rpm]	[Nm]	[rpm]	[Nm]	[rpm]	[Nm]	[rpm]
1	4	3.70	0.4	0.75	15	5	0.1	0.06	851	0.06	946	0.1	811	0.1	811
	7	6.75						0.1	467	0.1	519	0.18	444	0.18	444
2	14	13.73	1	0.7	30	10	0.12	0.19	229	0.19	255	0.34	218	0.34	218
	25	25.01						0.35	126	0.35	140	0.61	120	0.61	120
	46	45.56						0.64	69	0.64	77	1.12	66	1.12	66
3	68	68.06	2	0.65	45	15	0.13	0.88	46	0.88	51	1.55	44	1.55	44
	93	92.70						1.21	34	1.21	38	2.11	32	2.11	32
	169	168.84						2.2	19	2.2	21	3.84	18	3.84	18
	308	307.54						4	10	4	11	7	10	7	10

PK32BB								EC008				EC016			
Ns	in	ir	M _n [Nm]	Rd	R ₂ [N]	A ₂ [N]	Kg	S1 12V		S1 24V		S1 12V		S1 24V	
								[Nm]	[rpm]	[Nm]	[rpm]	[Nm]	[rpm]	[Nm]	[rpm]
1	4	3.70	0.6	0.75	40	10	0.12	0.06	851	0.06	946	0.1	811	0.1	811
	7	6.75						0.1	467	0.1	519	0.18	444	0.18	444
2	14	13.73	1.5	0.7	70	20	0.14	0.19	229	0.19	255	0.34	218	0.34	218
	25	25.01						0.35	126	0.35	140	0.61	120	0.61	120
	46	45.56						0.64	69	0.64	77	1.12	66	1.12	66
3	68	68.06	3	0.65	100	30	0.15	0.88	46	0.88	51	1.55	44	1.55	44
	93	92.70						1.21	34	1.21	38	2.11	32	2.11	32
	169	168.84						2.2	19	2.2	21	3.84	18	3.84	18
	308	307.54						4	10	4	11	7	10	7	10

P32								EC008				EC016			
Ns	in	ir	M _n [Nm]	Rd	R ₂ [N]	A ₂ [N]	Kg	S1 12V		S1 24V		S1 12V		S1 24V	
								[Nm]	[rpm]	[Nm]	[rpm]	[Nm]	[rpm]	[Nm]	[rpm]
1	4	3.70	0.75	0.8	40	10	0.16	0.06	851	0.06	946	0.11	811	0.11	811
	7	6.75						0.11	467	0.1	519	0.19	444	0.19	444
2	14	13.73	2.3	0.75	70	20	0.21	0.21	229	0.19	255	0.37	218	0.37	218
	25	25.01						0.38	126	0.35	140	0.66	120	0.66	120
	46	45.56						0.68	69	0.64	77	1.21	66	1.21	66
3	68	68.06	4.5	0.7	100	30	0.26	0.95	46	0.88	51	1.67	44	1.67	44
	93	92.70						1.3	34	1.21	38	2.27	32	2.27	32
	169	168.84						2.36	19	2.2	21	4.14	18	4.14	18
	308	307.54						4.31	10	4	11	7.54	10	7.54	10

Nota: le caselle in colore grigio indicano il superamento della coppia massima sopportata dal riduttore per il servizio in S1.
Per vedere tutti i rapporti di riduzione disponibili, vedere tabella a pag. B3

N.B.: boxes in grey indicate that maximum torque withstood by gear reducer for service in S1 is exceeded.
See the table on page B3 for all available ratios.

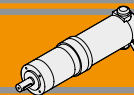

PK-P32 con motore CC

PK-P32 with DC motor

Tipo Type	Servizio Duty	Pn [W]	V [V]	I [A]	IC	FF	Mn [mNm]	n ₁ [rpm]	IP	Kg
EC008.120	S1	6.6	12	0.8	A	1	20	3150	20	0.15
EC008.240		7.3	24	0.38				3500		
EC016.120	S1	16	12	1.4	A	1	35	3000	20	0.2
EC016.240			24	0.7						

DC
PK-P-PM

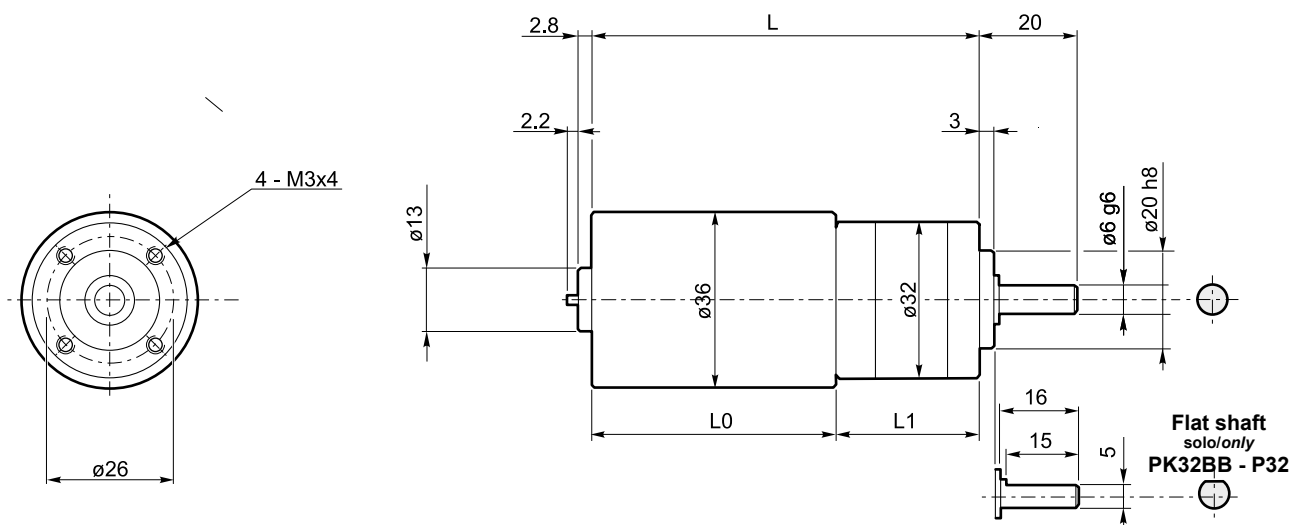

	Ns	L1	EC008		EC016	
			L0	L	L0	L
PK32SB	1	33	50	83	57	90
	2	42.5		92.5		99.5
	3	52		102		109
PK32BB P32	1	29.5		79.5		86.5
	2	39		89		96
	3	48.5		98.5		105.5

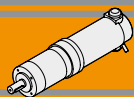

PM32 Low Noise con motore CC

PM32 Low Noise with DC motor

PM32 LN								EC008				EC016			
Ns	in	ir	M _n [Nm]	Rd	R ₂ [N]	A ₂ [N]	Kg	S1 12V		S1 24V		S1 12V		S1 24V	
								[Nm]	[rpm]	[Nm]	[rpm]	[Nm]	[rpm]	[Nm]	[rpm]
1	5	5.18	0.75	0.8	40	10	0.16	0.08	608	0.08	676	0.14	579	0.14	579
2	19	19.2	2.3	0.75	70	20	0.21	0.29	164	0.29	182	0.5	156	0.5	156
	27	26.85						0.40	117	0.40	130	0.7	112	0.7	112
3	71	71.16	4.5	0.7	100	30	0.26	1.00	44	1.00	49	1.74	42	1.74	42
	139	139.13						1.95	23	1.95	25	3.4	22	3.4	22
4	369	368.76	4.5	0.65	130	40	0.31	4.79	9	4.79	9	8.4	8	8.4	8
	721	720.98						9.37	4	9.37	5	16.4	4	16.4	4

Nota: le caselle in colore grigio indicano il superamento della coppia massima sopportata dal riduttore per il servizio in S1.

Per vedere tutti i rapporti di riduzione disponibili, vedere tabella a pag. B3

N.B.: boxes in grey indicate that maximum torque withstood by gear reducer for service in S1 is exceeded.

See the table on page B3 for all available ratios.

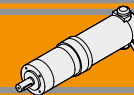

PM32 Low Noise con motore CC

PM32 Low Noise with DC motor

Tipo Type	Servizio Duty	Pn [W]	V [V]	I [A]	IC	FF	Mn [mNm]	n ₁ [rpm]	IP	Kg
EC008.120	S1	6.6	12	0.8	A	1	20	3150	20	0.15
EC008.240		7.3	24	0.38				3500		
EC016.120	S1	16	12	1.4	A	1	35	3000	20	0.2
EC016.240			24	0.7						

DC
PK-P-PM

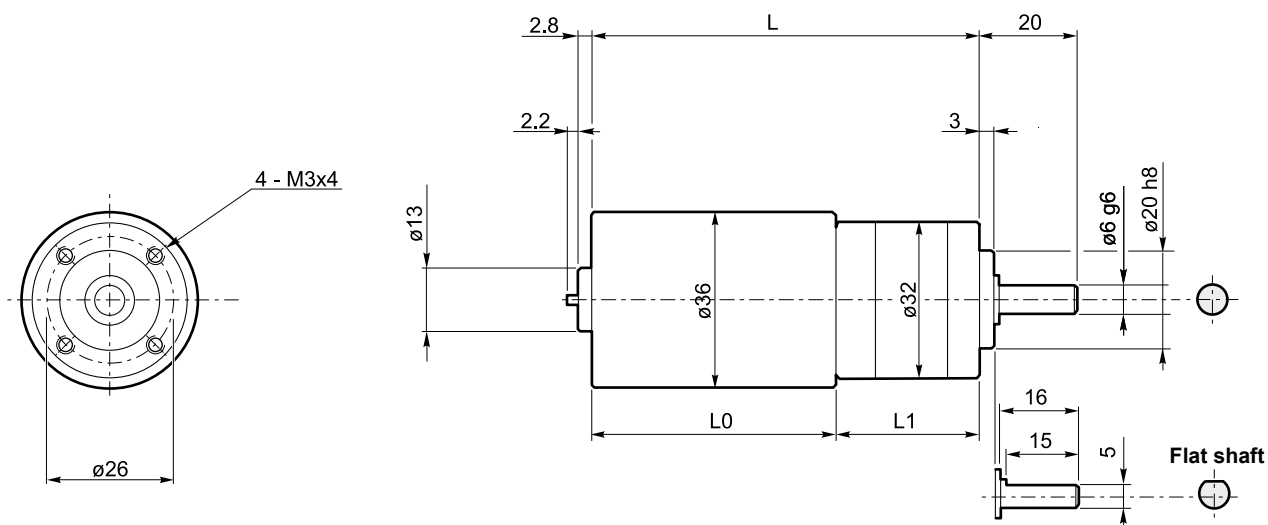

PM32 LN	Ns	L1	EC008		EC016	
			L0	L	L0	L
	1	29.5	50	79.5	57	86.5
	2	39		89		96
	3	48.5		98.5		105.5
	4	58		108		115

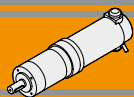

PK42 con motore CC

PK42- with DC motor

PK42SB								EC020			
Ns	in	ir	M _n [Nm]	Rd	R ₂ [N]	A ₂ [N]	Kg	S1 12/24V		S2 12/24V	
								[Nm]	[rpm]	[Nm]	[rpm]
1	4	3.70	0.75	0.8	40	10	0.16	0.18	770	0.3	770
	7	6.75						0.32	422	0.54	422
2	14	13.73	2.3	0.75	70	20	0.21	0.62	208	1.03	208
	25	25.01						1.13	114	1.88	114
	46	45.56						2.05	63	3.42	63
3	68	68.06	4.5	0.7	100	30	0.26	2.86	42	4.76	42
	93	92.70						3.89	31	6.49	31
	169	168.84						7.09	17	11.82	17
	308	307.54						12.92	9	21.53	9

PK42BB								EC020				EC030			
Ns	in	ir	M _n [Nm]	Rd	R ₂ [N]	A ₂ [N]	Kg	S1 12/24V		S2 12/24V		S1 24V		S2 24V	
								[Nm]	[rpm]	[Nm]	[rpm]	[Nm]	[rpm]	[Nm]	[rpm]
1	4	3.70	2	0.80	160	50	0.4	0.18	770	0.3	770	0.3	946	0.5	946
	7	6.75						0.32	422	0.54	422	0.54	519	0.9	519
2	14	13.73	5	0.75	230	80	0.5	0.62	208	1.03	208	1.03	255	1.6	255
	25	25.01						1.13	114	1.88	114	1.88	140	3	140
	46	45.56						2.05	63	3.42	63	3.42	77	5.5	77
3	68	68.06	10	0.70	300	110	0.6	2.86	42	4.76	42	4.76	51	7.6	51
	93	92.70						3.89	31	6.49	31	6.49	38	10.4	38
	169	168.84						7.09	17	11.8	17	11.8	21	18.9	21
	308	307.54						12.9	9	21.5	9	21.5	11	34	11

Nota: le caselle in colore grigio indicano il superamento della coppia massima sopportata dal riduttore per il servizio in S1.
Per vedere tutti i rapporti di riduzione disponibili, vedere tabella a pag. B3

N.B.: boxes in grey indicate that maximum torque withstood by gear reducer for service in S1 is exceeded.
See the table on page B3 for all available ratios.

Tipo Type	Servizio Duty	P _n [W]	V [V]	I [A]	IC	FF	M _n [Nm]	n ₁ [rpm]	IP	Kg
EC020.120	S1	20	12	3.2	B	1	0.06	2850	20	0.4
	S2 6'	30		4.6			0.10			
EC020.24E	S1	20	24	1.5			0.06	2850		
	S2 6'	30		2.5			0.10			
EC030.240	S1	30	24	2	B	1	0.10	3500	20	0.53
EC030.24E	S2 6'	50		3.5			0.16			



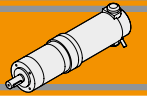

PK42 con motore CC

PK42- with DC motor

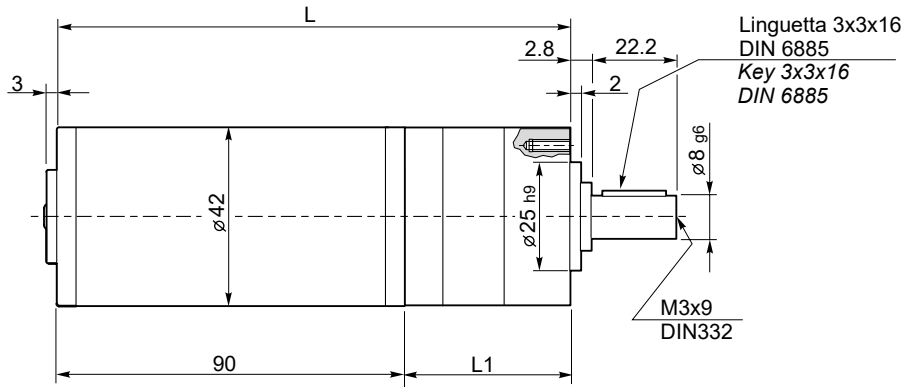
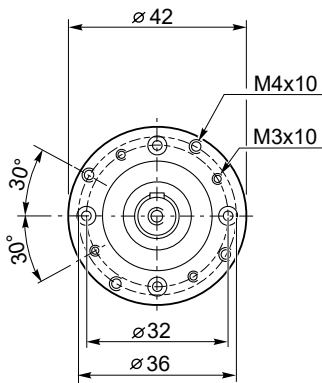

EC020 - EC030

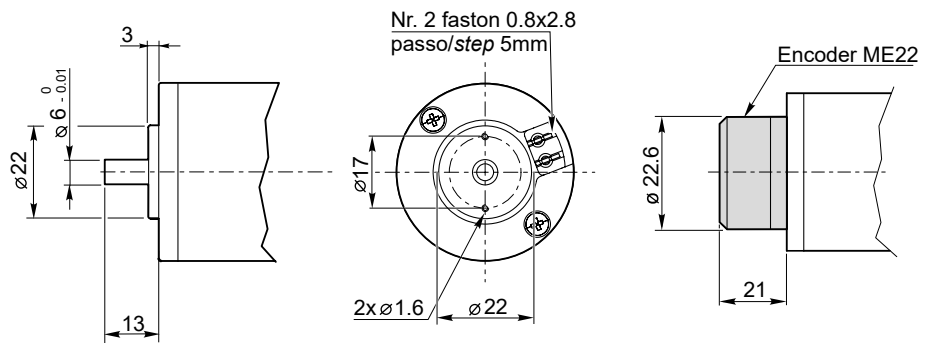

EC020.24E - EC030.24E



		EC020 - EC20.24E - EC030 - EC030.24E	
		Ns	L1
PK42SB PK42BB		1	60
		2	73
		3	86
			L
			150
			163
			176

DC
PK-P-PM

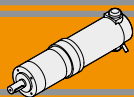

Micro motoriduttori CC epicycloidali DC Micro planetary gearmotors

PK42- con motore CC

PK42- with DC motor

PK42BB								EC035			
Ns	in	ir	M _n [Nm]	Rd	R ₂ [N]	A ₂ [N]	Kg	S1 12/24V		S2 12/24V	
								[Nm]	[rpm]	[Nm]	[rpm]
1	4	3.70	2	0.80	160	50	0.4	0.33	946	0.53	811
	7	6.75						0.59	519	0.97	444
2	14	13.73	5	0.75	230	80	0.5	1.13	255	1.85	218
	25	25.01						2.06	140	3.38	120
	46	45.56						3.76	77	6.15	66
3	68	68.06	10	0.70	300	110	0.6	5.24	51	8.58	44
	93	92.70						7.14	38	11.68	32
	169	168.84						13	21	21.27	18
	308	307.54						23.68	11	38.75	10

Nota: le caselle in colore grigio indicano il superamento della coppia massima sopportata dal riduttore per il servizio in S1.
Per vedere tutti i rapporti di riduzione disponibili, vedere tabella a pag. B3

N.B.: boxes in grey indicate that maximum torque withstood by gear reducer for service in S1 is exceeded.
See the table on page B3 for all available ratios.

Tipo Type	Servizio Duty	P _n [W]	V [V]	I [A]	IC	FF	M _n [Nm]	n ₁ [rpm]	IP	Kg
EC035.120	S1	35	12	5.2	F	1	0.11	3500	20	0.8
	S2 9'	55		8.0			0.18	3000		
EC035.240	S1	35	24	2.6			0.11	3500		
	S2 9'	55		4.0			0.18	3000		



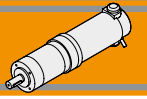

PK42- con motore CC

PK42- with DC motor

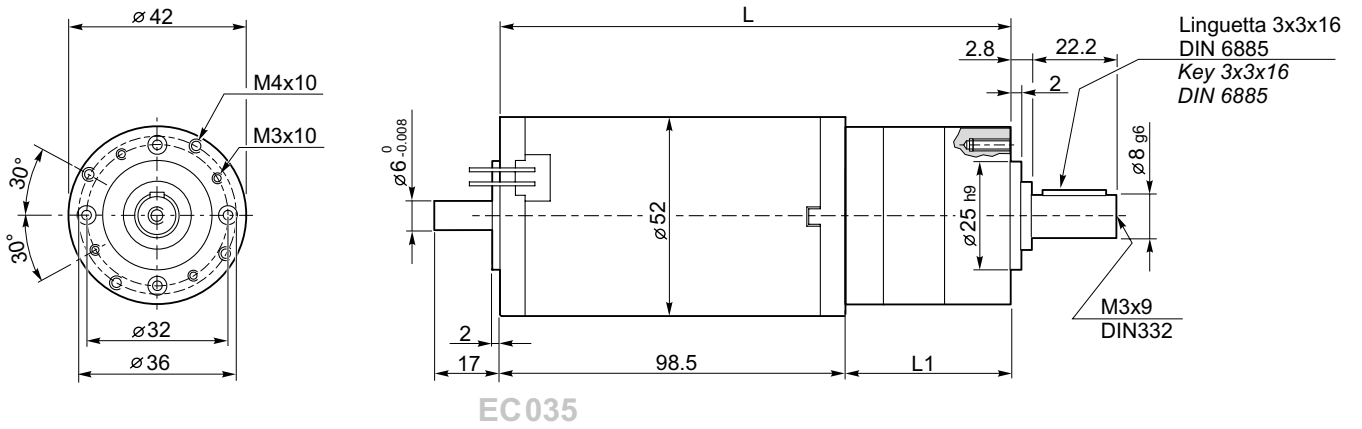

EC035

Encoder → I2

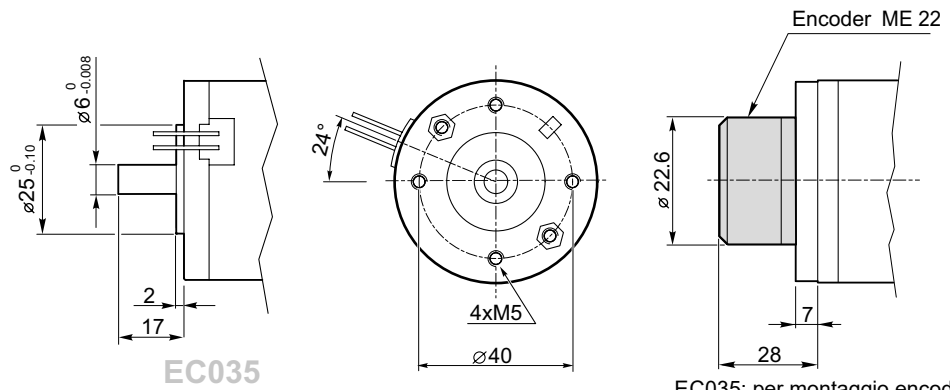

EC035

EC035: per montaggio encoder serve flangia AS204
EC035: encoder assembling needs flange AS204

			EC035	
PK42BB	Ns	L1	L	
	1	60	158.5	
	2	73	171.5	
	3	86	184.5	

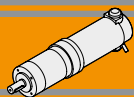

Micro motoriduttori CC epicycloidali DC Micro planetary gearmotors

P42 con motore CC

P42 with DC motor

P42								EC020				EC030			
Ns	in	ir	M _n [Nm]	Rd	R ₂ [N]	A ₂ [N]	Kg	S1 12/24V		S2 12/24V		S1 24V		S2 24V	
								[Nm]	[rpm]	[Nm]	[rpm]	[Nm]	[rpm]	[Nm]	[rpm]
1	4	3.70	3.0	0.8	160	50	0.4	0.18	770	0.30	770	0.30	946	0.5	946
	7	6.75						0.32	422	0.54	422	0.54	519	0.9	519
2	14	13.73	7.5	0.75	230	80	0.5	0.62	208	1.03	208	1.03	255	1.6	255
	25	25.01						1.13	114	1.88	114	1.88	140	3	140
	46	45.56						2.05	63	3.42	63	3.42	77	5.5	77
3	68	68.06	15.0	0.7	300	110	0.6	2.86	42	4.76	42	4.76	51	7.6	51
	93	92.70						3.89	31	6.49	31	6.49	38	10.4	38
	169	168.84						7.09	17	11.8	17	11.8	21	18.9	21
	308	307.54						12.9	9	21.5	9	21.5	11	34.4	11

Nota: le caselle in colore grigio indicano il superamento della coppia massima sopportata dal riduttore per il servizio in S1.
Per vedere tutti i rapporti di riduzione disponibili, vedere tabella a pag. B3

N.B.: boxes in grey indicate that maximum torque withstood by gear reducer for service in S1 is exceeded.
See the table on page B3 for all available ratios.

Tipo Type	Servizio Duty	Pn [W]	V [V]	I [A]	IC	FF	Mn [Nm]	n ₁ [rpm]	IP	Kg
EC020.120	S1	20	12	3.2	B	1	0.06	2850	20	0.4
	S2 6'	30		4.6			0.10			
EC020.24E	S1	20	24	1.5			0.06	2850		
	S2 6'	30		2.5			0.10			
EC030.240 EC030.24E	S1	30	24	2	B	1	0.10	3500	20	0.53
	S2 6'	50		3.5			0.16			

Azionamenti
Drives



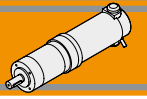

P42 con motore CC

P42 with DC motor

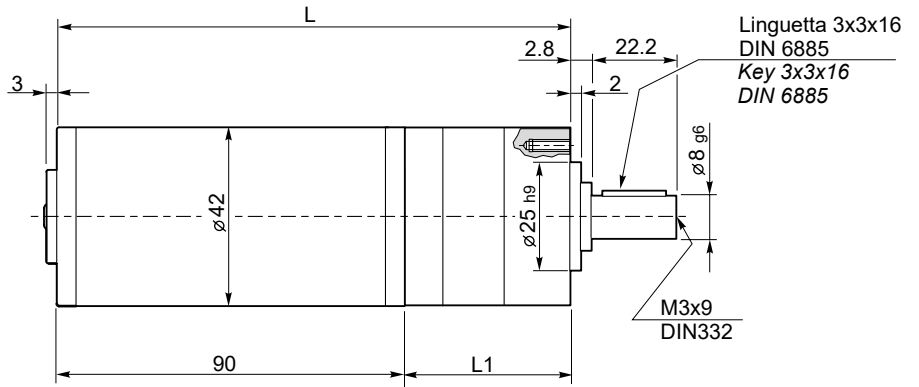
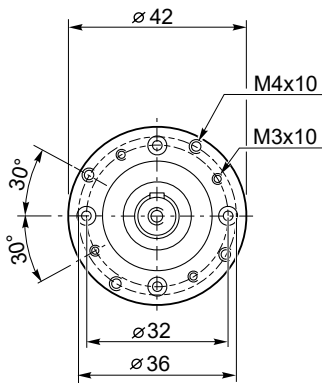

EC020 - EC030

Encoder

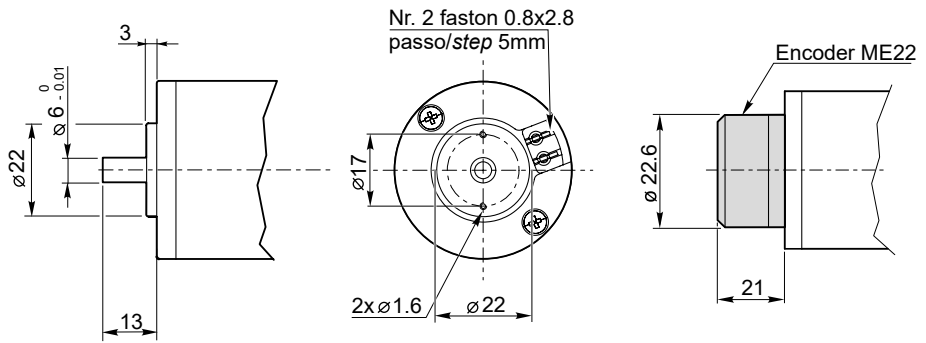

EC020.24E - EC030.24E

		EC020 - EC20.24E - EC030 - EC030.24E	
P42	Ns	L1	L
	1	60	150
	2	73	163
	3	86	176

DC

PK-P-PM

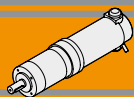

Micro motoriduttori CC epicycloidali DC Micro planetary gearmotors

P42 con motore CC

P42 with DC motor

P42								EC035				EC050			
								S1 12/24V		S2 12/24V		S1 12/24V		S2 12/24V	
Ns	in	ir	M _n [Nm]	Rd	R ₂ [N]	A ₂ [N]	Kg	[Nm]	[rpm]	[Nm]	[rpm]	[Nm]	[rpm]	[Nm]	[rpm]
1	4	3.70	3.0	0.8	160	50	0.4	0.33	946	0.53	811	0.47	811	0.65	811
	7	6.75						0.59	519	0.97	444	0.86	444	1.19	444
2	14	13.73	7.5	0.75	230	80	0.5	1.13	255	1.85	218	1.65	218	2.27	218
	25	25.01						2.06	140	3.38	120	3	120	4.13	120
	46	45.56						3.76	77	6.15	66	5.47	66	7.52	66
3	68	68.06	15.0	0.7	300	110	0.6	5.24	51	8.58	44	7.62	44	10.48	44
	93	92.70						7.14	38	11.68	32	10.38	32	14.28	32
	169	168.84						13	21	21.27	18	18.91	18	26	18
	308	307.54						23.68	11	38.75	10	34.44	10	47.36	10

Nota: le caselle in colore grigio indicano il superamento della coppia massima sopportata dal riduttore per il servizio in S1.
Per vedere tutti i rapporti di riduzione disponibili, vedere tabella a pag. B3

N.B.: boxes in grey indicate that maximum torque withstood by gear reducer for service in S1 is exceeded.
See the table on page B3 for all available ratios.

Tipo Type	Servizio Duty	P _n [W]	V [V]	I [A]	IC	FF	M _n [Nm]	n ₁ [rpm]	IP	Kg
EC035.120	S1	35	12	5.2	F	1	0.11	3500	20	0.8
	S2 9'	55		8.0			0.18	3000		
EC035.240	S1	35	24	2.6			0.11	3500		
	S2 9'	55		4.0			0.18	3000		
EC050.12E	S1	50	12	6.8	F	1	0.16	3000	20	1.2
	S2 9'	70		9.4			0.22			
EC050.24E	S1	50	24	3.4			0.16			
	S2 9'	70		4.7			0.22			



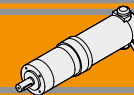

P42 con motore CC

P42 with DC motor

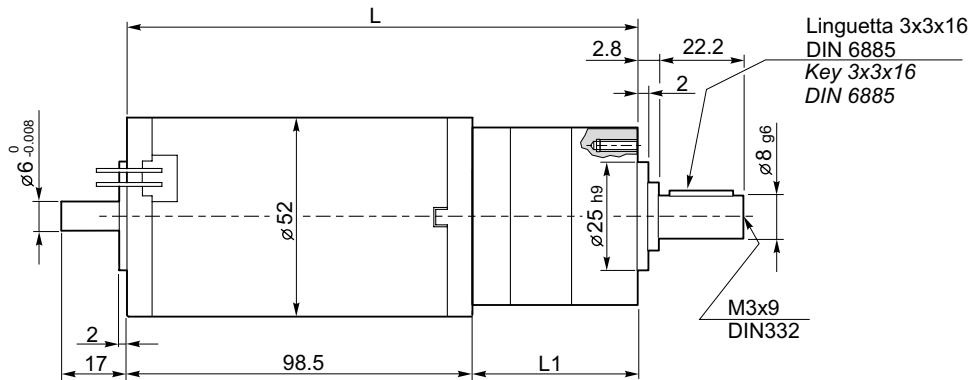
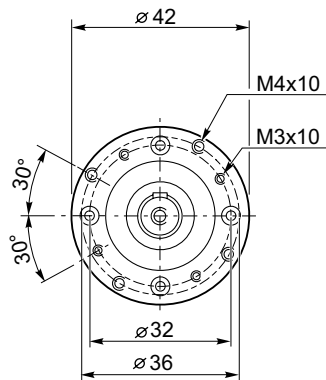

EC035

Linguetta 3x3x16
DIN 6885
Key 3x3x16
DIN 6885

Encoder ME 22

EC035: per montaggio encoder
serve flangia AS204
EC035: encoder assembling
needs flange AS204

Encoder

I2

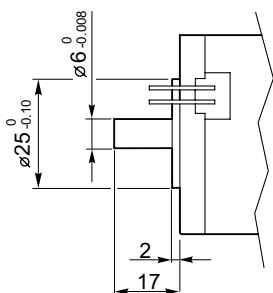

EC035

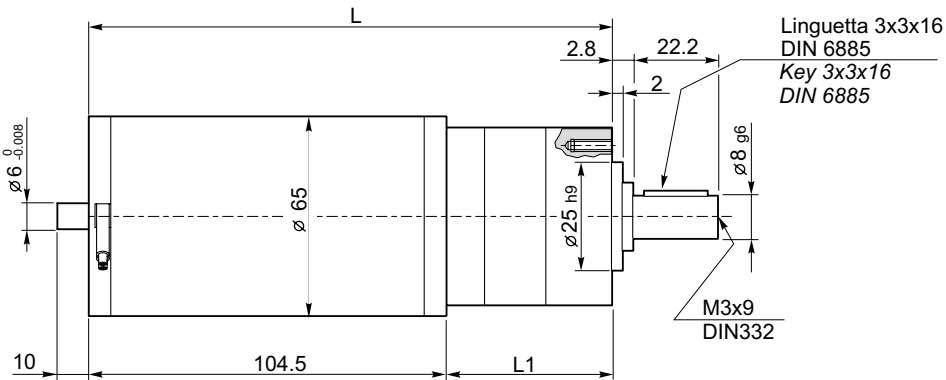
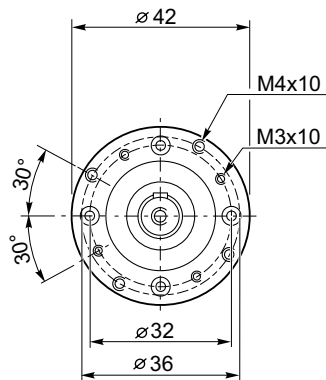
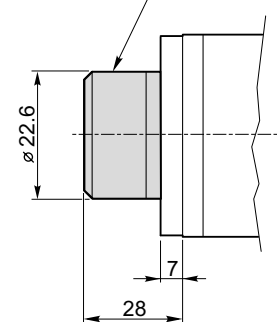
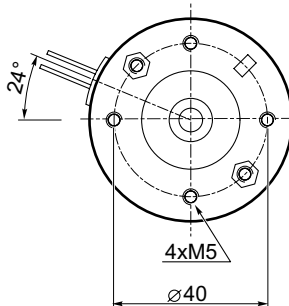

EC050

Linguetta 3x3x16
DIN 6885
Key 3x3x16
DIN 6885

Encoder

I2

Freno / Brake

B20

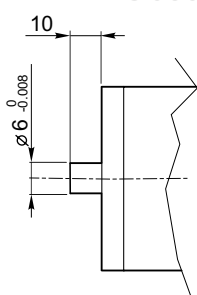

EC050

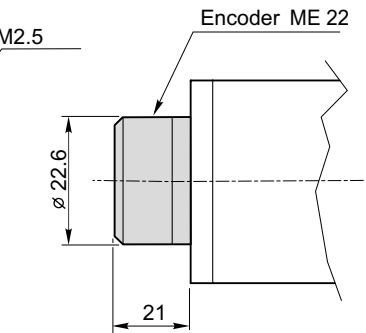
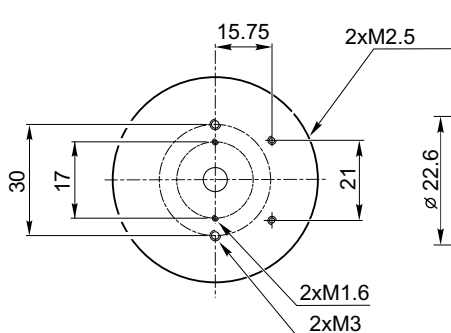

P42	Ns	L1	EC035	EC050
			L	L
	1	60	158.5	163
	2	73	171.5	176
	3	86	184.5	189

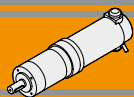

Micro motoriduttori CC epicicloidali DC Micro planetary gearmotors

PK-P52 con motore CC

PK-P52 with DC motor

PK52BB								EC050				EC070			
Ns	in	ir	M _n [Nm]	Rd	R ₂ [N]	A ₂ [N]	Kg	S1 12/24V		S2 12/24V		S1 12/24V		S2 12/24V	
								[Nm]	[rpm]	[Nm]	[rpm]	[Nm]	[rpm]	[Nm]	[rpm]
1	4	3.70	3.0	0.75	200	60	0.4	0.44	811	0.61	811	0.61	811	0.86	811
	7	6.75						1.11	444	1.11	444	1.11	444	1.57	444
2	14	13.73	8.0	0.7	320	100	0.5	1.53	218	2.11	218	2.11	218	2.97	218
	25	25.01						2.8	120	3.85	120	3.85	120	5.42	120
	46	45.56						5.10	66	7.01	66	7.01	66	9.88	66
3	68	68.06	17.0	0.65	450	150	0.6	7.08	44	9.73	44	9.73	44	13.71	44
	93	92.70						9.64	32	13.26	32	13.25	32	18.67	32
	169	168.84						17.55	18	24.14	18	24.14	18	34.02	18
	308	307.54						31.98	10	43.98	10	43.98	10	61.97	10

Nota: le caselle in colore grigio indicano il superamento della coppia massima sopportata dal riduttore per il servizio in S1.
Per vedere tutti i rapporti di riduzione disponibili, vedere tabella a pag. B3

N.B.: boxes in grey indicate that maximum torque withstood by gear reducer for service in S1 is exceeded.
See the table on page B3 for all available ratios.

P52								EC050				EC070			
Ns	in	ir	M _n [Nm]	Rd	R ₂ [N]	A ₂ [N]	Kg	S1 12/24V		S2 12/24V		S1 12/24V		S2 12/24V	
								[Nm]	[rpm]	[Nm]	[rpm]	[Nm]	[rpm]	[Nm]	[rpm]
1	4	3.70	4.0	0.8	200	60	0.7	0.47	811	0.65	811	0.65	811	0.92	811
	7	6.75						0.86	444	1.19	444	1.19	444	1.67	444
2	14	13.73	12.0	0.75	320	100	0.9	1.65	219	2.27	219	2.26	218	3.19	218
	25	25.01						3.0	120	4.13	120	4.12	120	5.81	120
	46	45.56						5.47	66	7.52	66	7.52	66	10.59	66
3	68	68.06	25.0	0.7	450	150	1.1	7.62	44	10.48	44	10.48	44	14.77	44
	93	92.70						10.38	32	14.28	32	14.28	32	20.12	32
	169	168.84						18.9	18	26.0	18	26.00	18	36.64	18
	308	307.54						34.4	9.8	47.36	9.8	47.36	10	66.74	10

Tipo Type	Servizio Duty	P _n [W]	V [V]	I [A]	IC	FF	M _n [Nm]	n ₁ [rpm]	IP	Kg
EC050.12E	S1	50	12	6.8	F	1	0.16	3000	20	1.2
	S2 9'	70		9.4			0.22			
EC050.24E	S1	50	24	3.4			0.16			
	S2 9'	70		4.7			0.22			
EC070.12E	S1	70	12	8.4	F	1	0.22	3000	20	1.7
	S2 30'	100		11.8			0.31			
EC070.24E	S1	70	24	4.2			0.22			
	S2 30'	100		5.9			0.31			



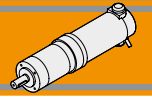

PK-P52 con motore CC

PK-P52 with DC motor

DC
PK-P-PM

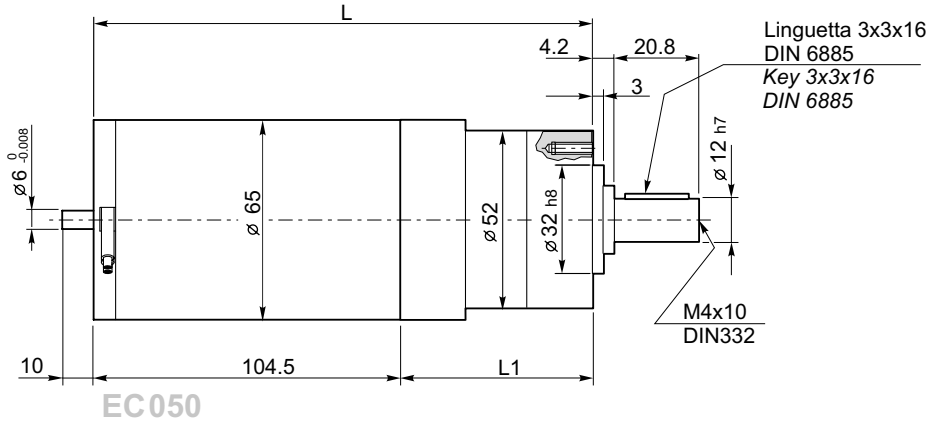
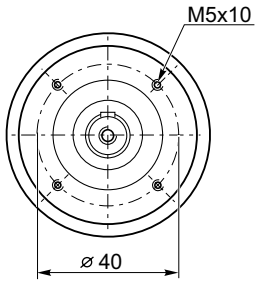

EC050

Encoder → I2

Freno / Brake → B20

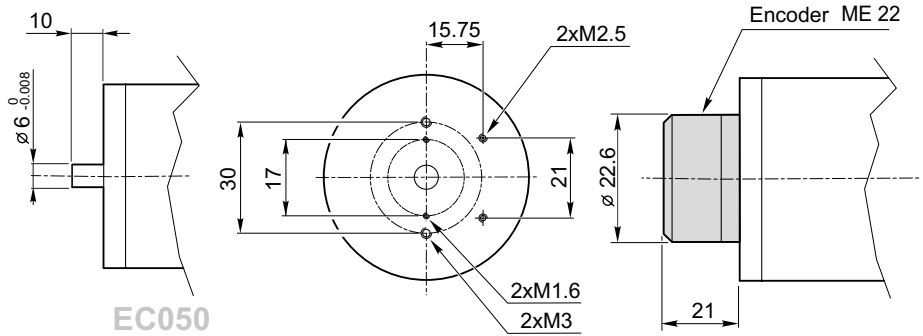

EC050

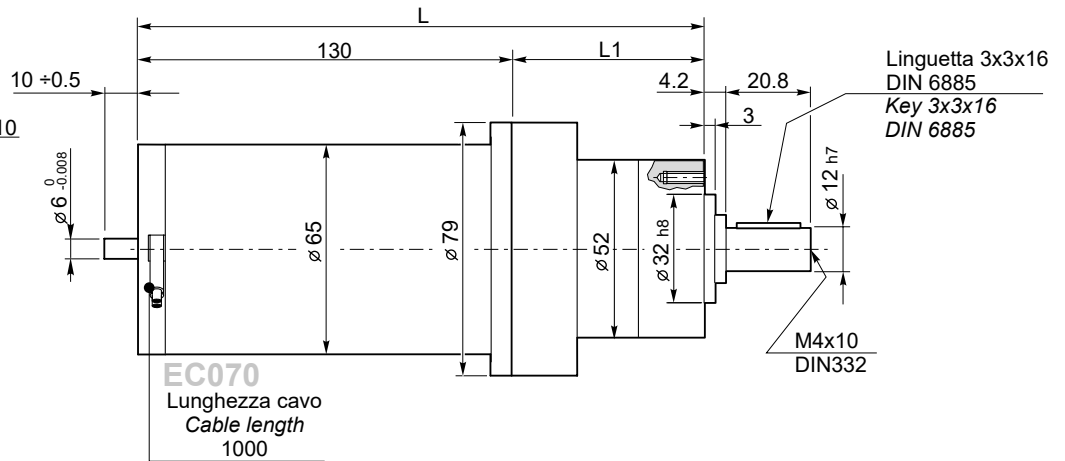
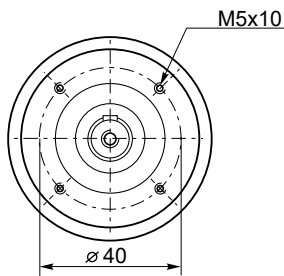

EC070

Lunghezza cavo
Cable length
1000

Encoder → I2

Freno / Brake → B20

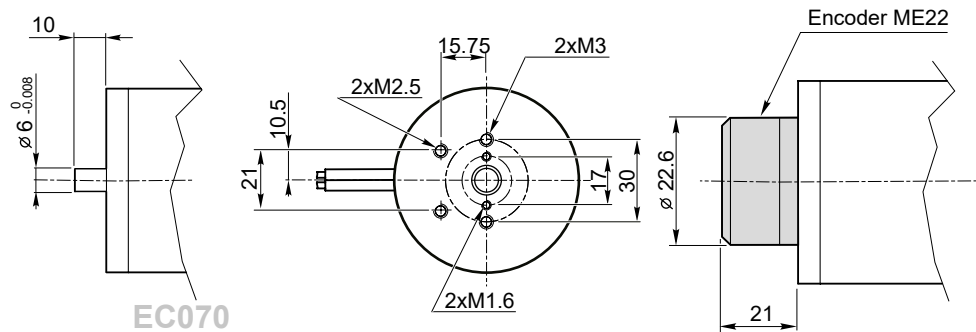

EC070

		EC050		EC070	
	Ns	L	L1	L	L1
PK52BB	1	177	72.5	202.5	72.5
	2	191	86.5	216.5	86.5
	3	205	100.5	230.5	100.5
P52	1	—	—	204	74
	2	—	—	218	88
	3	—	—	232	102

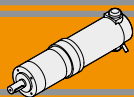

P52 con motore CC

P52 with DC motor

P52								EC100				EC180			
Ns	in	ir	M _n [Nm]	Rd	R ₂ [N]	A ₂ [N]	Kg	S1 12/24V		S2 12/24V		S1 12/24V		S2 12/24V	
								[Nm]	[rpm]	[Nm]	[rpm]	[Nm]	[rpm]	[Nm]	[rpm]
1	4	3.70	4.0	0.8	200	60	0.7	0.92	811	1.27	811	1.69	811	2.37	811
	7	6.75						1.67	444	2.32	444	3.08	444	4.32	444
2	14	13.73	12.0	0.75	320	100	0.9	3.19	218	4.43	218	5.87	218	8.24	218
	25	25.01						5.81	120	8.07	120	10.69	120	15.01	120
	46	45.56						10.59	66	14.69	66	19.48	66	27.34	66
3	68	68.06	25.0	0.7	450	150	1.1	14.77	44	20.49	44	27.16	44	38.11	44
	93	92.70						20.12	32	27.9	32	36.99	32	51.91	32
	169	168.84						36.64	18	50.82	18	67.37	18	94.55	18
	308	307.54						66.74	10	92.57	10	122.7	10	177.2	10

Nota: le caselle in colore grigio indicano il superamento della coppia massima sopportata dal riduttore per il servizio in S1.
Per vedere tutti i rapporti di riduzione disponibili, vedere tabella a pag. B3

N.B.: boxes in grey indicate that maximum torque withstood by gear reducer for service in S1 is exceeded.
See the table on page B3 for all available ratios.

Tipo Type	Servizio Duty	Pn [W]	V [V]	I [A]	IC	FF	Mn [Nm]	n1 [rpm]	IP	Kg
EC100.120	S1	100	12	12	F	1	0.31	3000	40	2.7
	S2 25'	140		16.8			0.43			
EC100.240 EC100.24E	S1	100	24	6			0.31			
	S2 25'	140		8.4			0.43		20	
EC180.120	S1	180	12	21.5	F	1	0.57	3000	40	3.4
	S2 25'	250		30			0.8			
EC180.240 EC180.24E	S1	180	24	10.8			0.57			
	S2 25'	250		15			0.8		20	



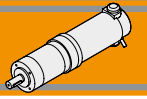

P52 con motore CC

P52 with DC motor

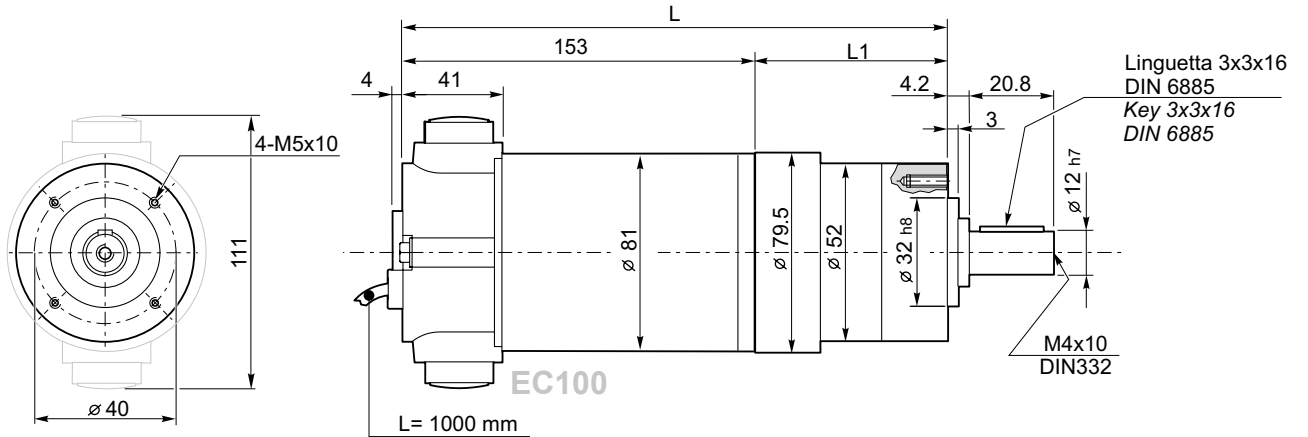

Encoder → I2

Freno / Brake → B20

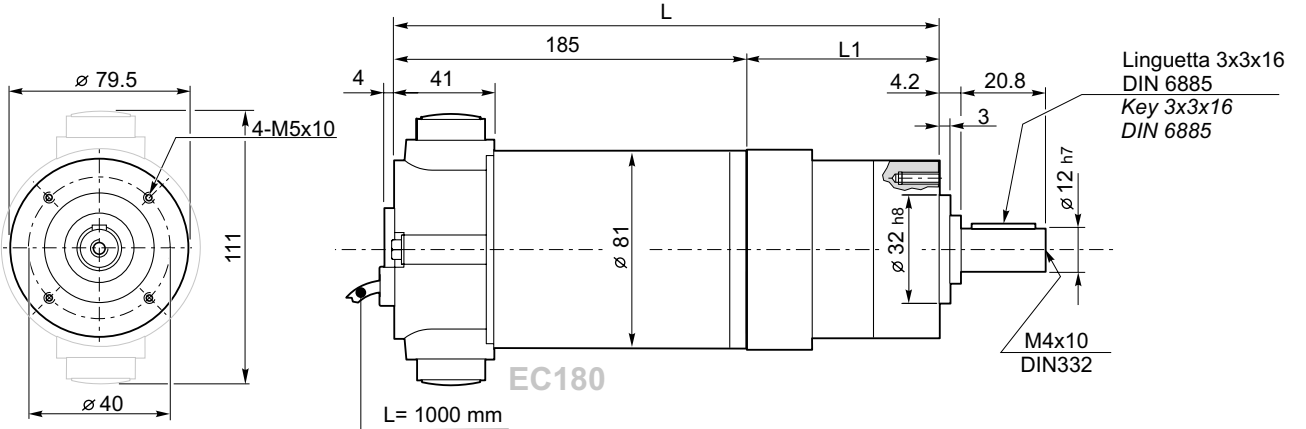
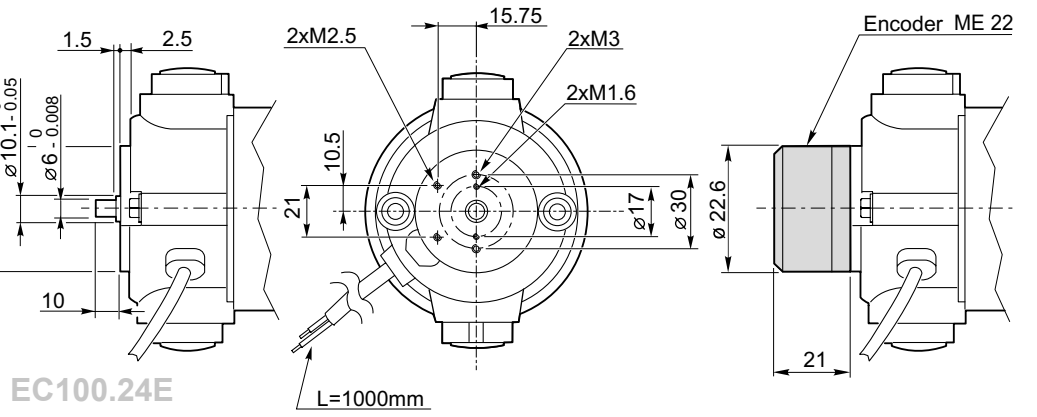

Encoder → I2

Freno / Brake → B20

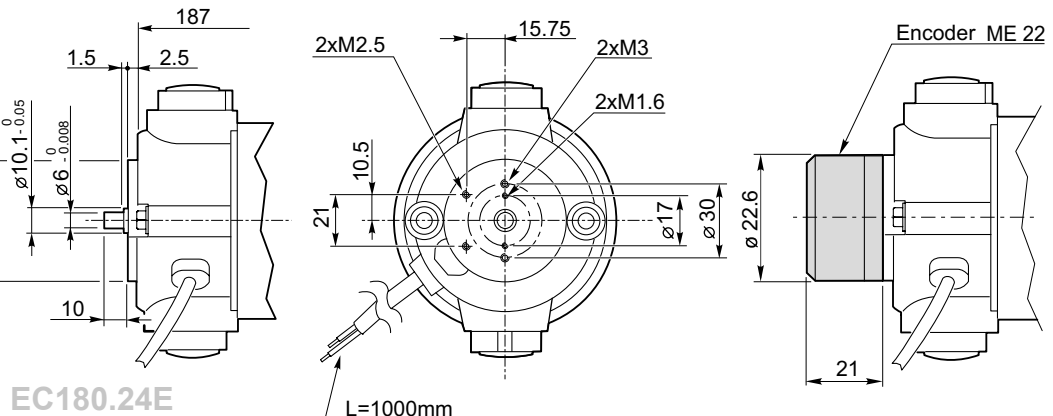

P52	Ns	EC100		EC180	
		L	L1	L	L1
	1	227	74	259	74
	2	241	88	273	88
	3	255	102	287	102

DC
PK-P-PM

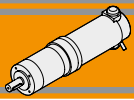

Freno

Brake

Freno / Brake

Freno con leva di sblocco/ Brake with hand release

EC050...BR
EC070...BR

EC050...BRL
EC070...BRL

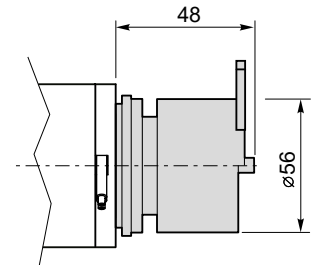
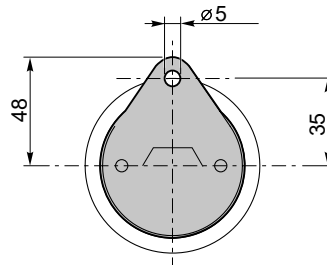
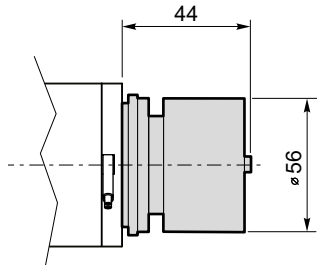

	P_n [W]	V [V]	M_n [Nm]	n₁ [min ⁻¹]
Caratteristiche del freno / Break features	14	12	2	3000
		24		

EC100.24E BR
EC180.24E BR

EC100.24E BRL
EC180.24E BRL

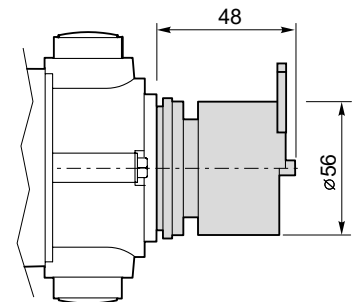
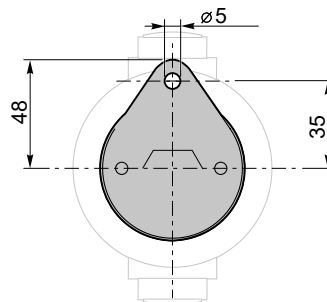
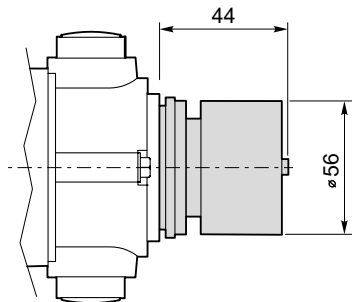

	P_n [W]	V [V]	M_n [Nm]	n₁ [min ⁻¹]
Caratteristiche del freno / Break features	14	12	2	3000
		24		

Micro motoriduttori CC a vite senza fine DC Micro wormgearmotors

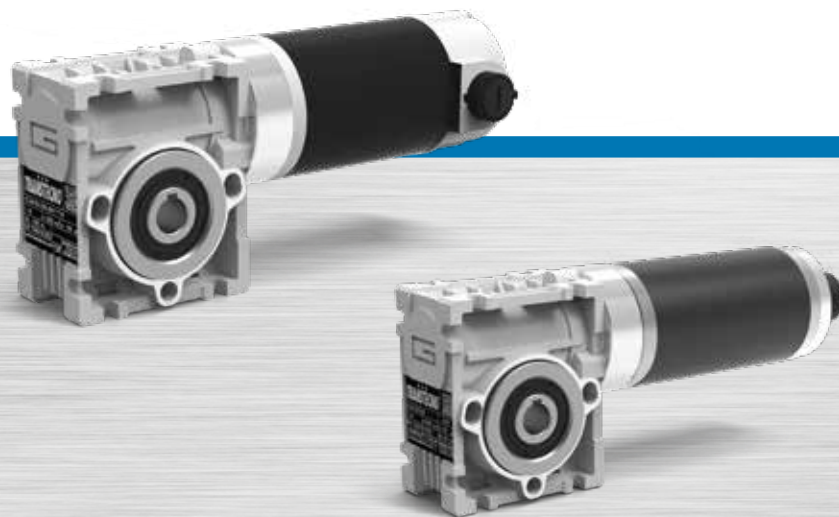

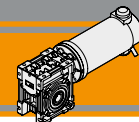

Indice	Index	Pag. Page
Caratteristiche tecniche	<i>Technical features</i>	C2
Designazione	<i>Classification</i>	C2
Simbologia	<i>Symbols</i>	C2
Lubrificazione	<i>Lubrication</i>	C2
Carichi radiali	<i>Radial loads</i>	C3
Dati di dentatura	<i>Toothing data</i>	C3
Rendimento	<i>Efficiency</i>	C3
CM026 con motore CC	<i>CM026 with DC motor</i>	C4
CM030 con motore CC	<i>CM030 with DC motor</i>	C8
Dimensioni	<i>Dimensions</i>	C10
Opzioni	<i>Options</i>	C10
Accessori	<i>Accessories</i>	C11

Questa sezione annulla e sostituisce ogni precedente edizione o revisione. Qualora questa sezione non Vi sia giunta in distribuzione controllata, l'aggiornamento dei dati ivi contenuto non è assicurato. **In tal caso la versione più aggiornata è disponibile sul nostro sito internet www.intecno-srl.com**

*This section replaces any previous edition and revision. If you obtained this catalogue other than through controlled distribution channels, the most up to date content is not guaranteed. **In this case the latest version is available on our web site www.intecno-srl.com***

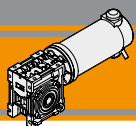

Micro motoriduttori CC a vite senza fine DC Micro wormgearmotors

Caratteristiche tecniche

Technical features





Le caratteristiche principali dei motoriduttori in CC a vite senza fine della serie CM sono:

The main features of DC wormgearmotors range CM are:

- Alimentazione in bassa tensione 12/24 Vcc
- Possibilità di montaggio encoder
- Potenze motore disponibili da 55 a 250W S2
- Magneti permanenti in ferrite
- Carcasse dei riduttori in pressofusione di alluminio
- Lubrificazione permanente con olio sintetico.
- Low voltage power supply 12/24 Vdc
- Suitable for encoder assembly
- Motor power ratings available from 55 to 250W S2
- Ferrite permanent magnets
- Die-cast aluminum housing
- Permanent synthetic oil long-life lubrication.

Designazione

Classification

RIDUTTORE / GEARBOX				MOTORE / MOTOR		
CM	026	20	U	EC035	24V	—
Tipo Type	Grandezza Size	Rapporto in Ratio in	Versione Version	Tipo Type	Tensione Voltage	Opzioni Options
CM	026 030	Vedere tabelle See tables	U F	EC035 EC050 EC070 EC100 EC180	12V 24V	Encoder  Freno / Brake 
Versione Riduttore Gearbox Version <div style="display: flex; justify-content: space-around; align-items: center;">    </div>						
U	FD	FS				

Simbologia

Symbols

Ns	n° stadi / No. stages	Pn	[W]	Potenza nominale / Nominal power
in	rapporto nominale / nominal ratio	V	[V]	Tensione / Voltage
ir	rapporto reale / real ratio	I	[A]	Assorbimento / Current
M _n	[Nm] coppia in uscita in funzionamento continuativo S1 output torque for continuous operation S1	IC		Classe di isolamento termico / Thermal insulation class
Rd	rendimento dinamico / efficiency	FF		Fattore di forma / Form factor
R ₂	[N] massimo carico radiale al centro dell'albero uscita max. radial load at output shaft centre	n ₁	[Rpm]	Giri / Speed
A ₂	[N] massimo carico assiale / max. axial load	IP		Grado di protezione / Enclosure protection
		Kg		Peso / Weight

Lubrificazione

Lubrication

I riduttori a vite senza fine della serie CM026 e CM030 sono lubrificati a vita con olio sintetico di viscosità 320 e possono essere installati in qualunque posizione di montaggio.
Temperatura ambiente 0 ÷ 40 °C (in assenza di congelamento ed in assenza di condensa).
Per temperature diverse, contattare nostro UT.

Permanent synthetic oil long-life lubrication allow to use CM026 and CM030 wormgearbox range in all mounting position.
Ambient temperature 0 ÷ 40 °C (in the absence of freezing and condensation).
For temperature outside this range please contact our technical dept.

	Quantità di olio (litri) / Oil quantity (litres)					
	B3	B8	B6	B7	V5	V6
CM026				0.015		
CM030				0.03		

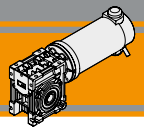

Carichi radiali

Radial loads

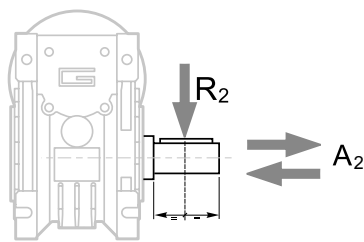

$$A_2 = R_2 \times 0.2$$

n ₂ [min ⁻¹]	R ₂ [N]	
	CM026	CM030
187	400	674
140	490	743
93	580	851
70	610	936
56	610	1008
47	610	1069
35	610	1179
28	610	1270
23	610	1356
18	610	1471
14	610	1600

Quando il carico radiale risultante non è applicato sulla mezza-
ria dell'albero occorre calcolare quello effettivo con la seguente
formula:

When the resulting radial load is not applied on the centre line
of the shaft it is necessary to calculate the effective load with the
following formula:

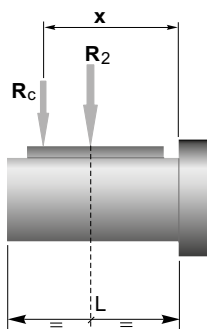

$$R_c = \frac{R_2 \cdot a}{(b+x)} \leq R_{2MAX}$$

$$R \leq R_c$$

a, b = valori riportati nella tabella
a, b = values given in the table

	CM	
	026	030
a	56	65
b	43	50
R _{2MAX}	610	1600

Dati di dentatura

Toothing data

	Dati della coppia vite-corona Worm wheel data	Rapporto / Ratio											
		5	7.5	10	15	20	25	30	40	50	60	80	100
CM026	Z	6	4	3	2	2		1	1	1	1		
	β	34° 35'	24° 41'	19° 1'	12° 57'	10° 30'		6° 33'	5° 17'	4° 26'	3° 49'		
CM030	Z	6	4	3	2	2	2	1	1	1	1	1	1
	β	27° 4'	24° 28'	18° 50'	12° 49'	10° 23'	8° 43'	6° 29'	5° 14'	4° 23'	3° 46'	2° 57'	2° 25'

Rendimento

Efficiency

	n ₁ [min ⁻¹]	Rendimento Efficiency	Rapporto / Ratio											
			5	7.5	10	15	20	25	30	40	50	60	80	100
CM026	2800	Rd	0.89	0.87	0.85	0.83	0.80		0.73	0.68	0.64	0.60		
		Rs	0.72	0.71	0.68	0.61	0.56		0.46	0.41	0.36	0.34		
CM030	2800	Rd	0.89	0.88	0.86	0.84	0.81	0.78	0.74	0.70	0.65	0.62	0.57	0.52
		Rs	0.72	0.67	0.63	0.55	0.50	0.43	0.39	0.35	0.31	0.27	0.23	0.21

Reversibilità e irreversibilità

Reversibility and irreversibility

La tabella sottostante riporta a titolo puramente
indicativo i vari gradi di reversibilità/irreversibilità
nei riduttori a vite senza fine in funzione del rendi-
mento dinamico Rd e statico Rs.

The table below is provided for reference purposes
only. It contains the various degrees of reversibi-
lity/irreversibility of wormgearboxes in relation to
dynamic Rd and static Rs efficiency.

Rd	Reversibilità e irreversibilità dinamica	Dynamic reversibility and irreversibility
> 0.60	Reversibilità dinamica	Dynamic reversibility
0.50 - 0.60	Reversibilità dinamica incerta	Uncertain dynamic reversibility
0.40 - 0.50	Buona irreversibilità dinamica	Good dynamic irreversibility
<0.40	Irreversibilità dinamica	Dynamic irreversibility
Rs	Reversibilità e irreversibilità statica	Static reversibility and irreversibility
> 0.55	Reversibilità statica	Static reversibility
0.50 - 0.55	Reversibilità statica incerta	Uncertain static reversibility
<0.50	Irreversibilità statica	Static irreversibility

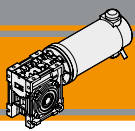

Micro motoriduttori CC a vite senza fine DC Micro wormgearmotors

CM026 con motore CC

CM026 with DC motor

CM026 n ₁ =3000 rpm			EC035 S2 12/24V	
ir	M _n [Nm]	Kg	[Nm]	[rpm]
5	10	0.8	0.8	600
7.5	11		1.2	400
10	11		1.5	300
15	11		2.2	200
20	11		2.9	150
30	12		3.9	100
40	11		4.9	75
50	10		5.8	60
60	9		6.5	50

Tipo Type	Servizio Duty	P _n [W]	V [V]	I [A]	IC	FF	M _n [Nm]	n ₁ [rpm]	IP	Kg
EC035.120	S2 9'	55	12	8.0	F	1	0.18	3000	20	0.8
EC035.240	S2 9'	55	24	4.0			0.18	3000		

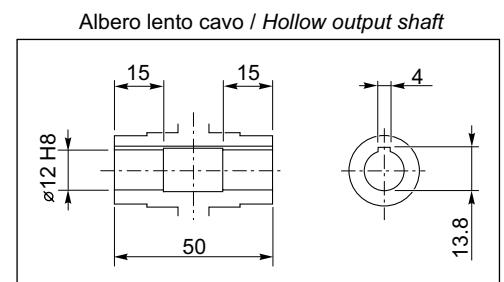
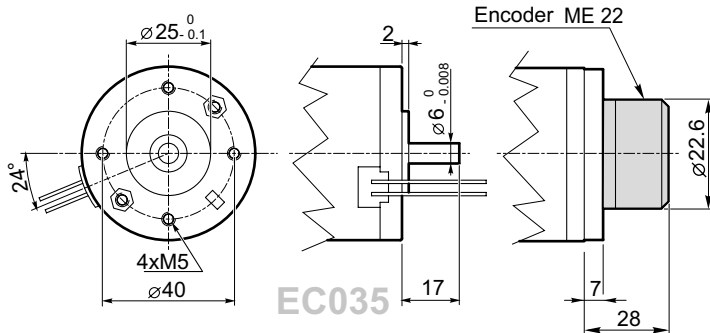
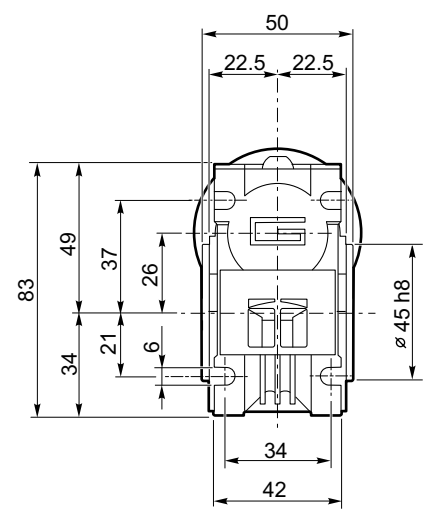
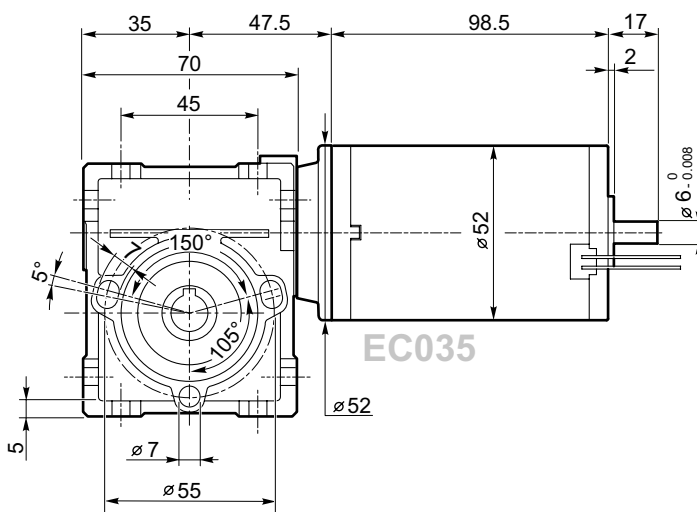

EC035: per montaggio encoder
serve flangia AS204
EC035: encoder assembling
needs flange AS204

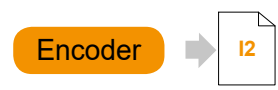

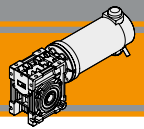

CM026 con motore CC

CM026 with DC motor

CM026 n ₁ =3000 rpm			EC050 S2 12/24V		
ir	M _n [Nm]	Kg	[Nm]	[rpm]	
5	10		0.8	1	600
7.5	11			1.5	400
10	11			2	300
15	11			2.8	200
20	11			3.6	150
30	12			4.8	100
40	11			6	75
50	10			7	60
60	9	8		50	

Tipo Type	Servizio Duty	P _n [W]	V [V]	I [A]	IC	FF	M _n [Nm]	n ₁ [rpm]	IP	Kg
EC050.12E	S2 9'	70	12	9.4	F	1	0.22	3000	20	1.2
EC050.24E	S2 9'	70	24	4.7			0.22			

Azionamenti
Drives

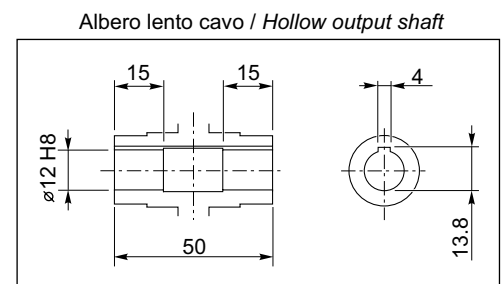
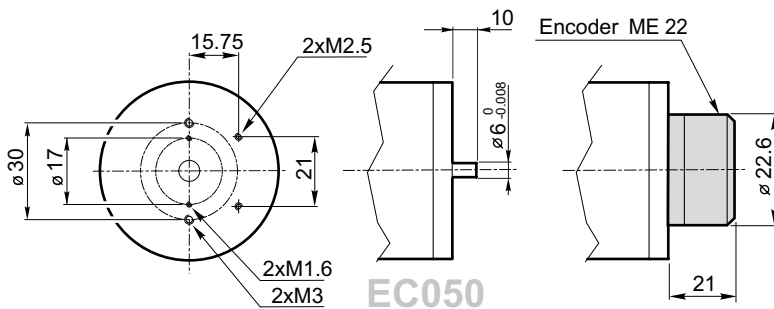
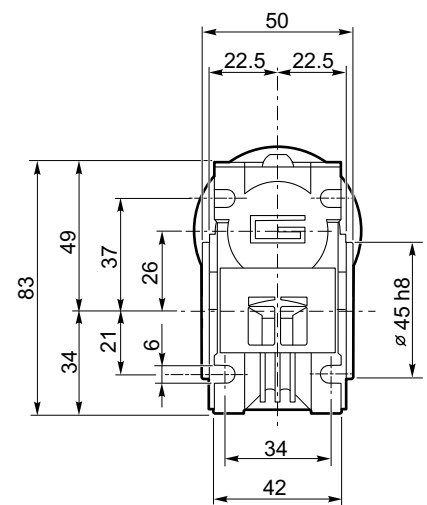
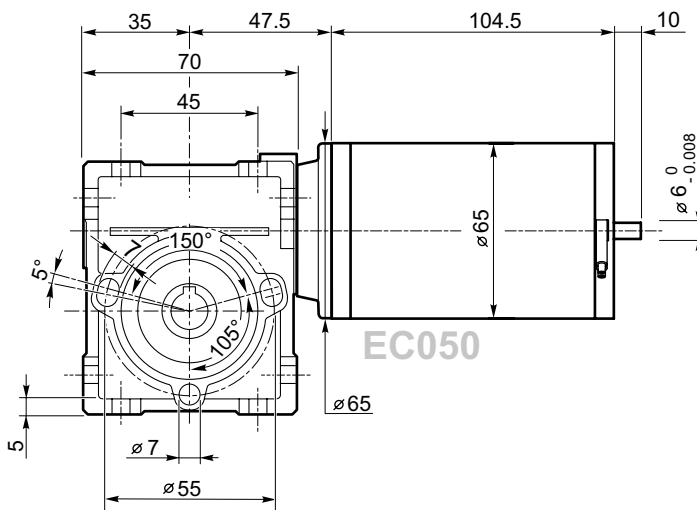

Encoder → I2

Freno / Brake → C12

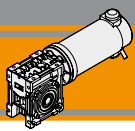

Micro motoriduttori CC a vite senza fine DC Micro wormgearmotors

CM026 con motore CC

CM026 with DC motor

CM026 n ₁ =3000 rpm			EC070			
ir	M _n [Nm]	Kg	S1 12/24 V		S2 12/24 V	
			[Nm]	[rpm]	[Nm]	[rpm]
5	10	0.8	0.98	600	1.38	600
7.5	11		1.44	400	2.03	400
10	11		1.87	300	2.63	300
15	11		2.74	200	3.86	200
20	11		3.52	150	4.96	150
30	12		4.82	100	6.79	100
40	11		5.98	75	8.43	75
50	10		7.04	60	9.92	60
60	9		7.92	50	11.16	50

Nota: le caselle in colore grigio indicano il superamento della coppia massima sopportata dal riduttore per il servizio in S1.
N.B.: boxes in grey indicate that maximum torque withstood by gear reducer for service in S1 is exceeded.

Tipo Type	Servizio Duty	P _n [W]	V [V]	I [A]	IC	FF	M _n [Nm]	n ₁ [rpm]	IP	Kg
EC070.12E	S1	70	12	8.4	F	1	0.22	3000	20	1.7
	S2 20'	100		11.8			0.31			
EC070.24E	S1	70	24	4.2						
	S2 20'	100		5.9			0.31			

Azionamenti
Drives

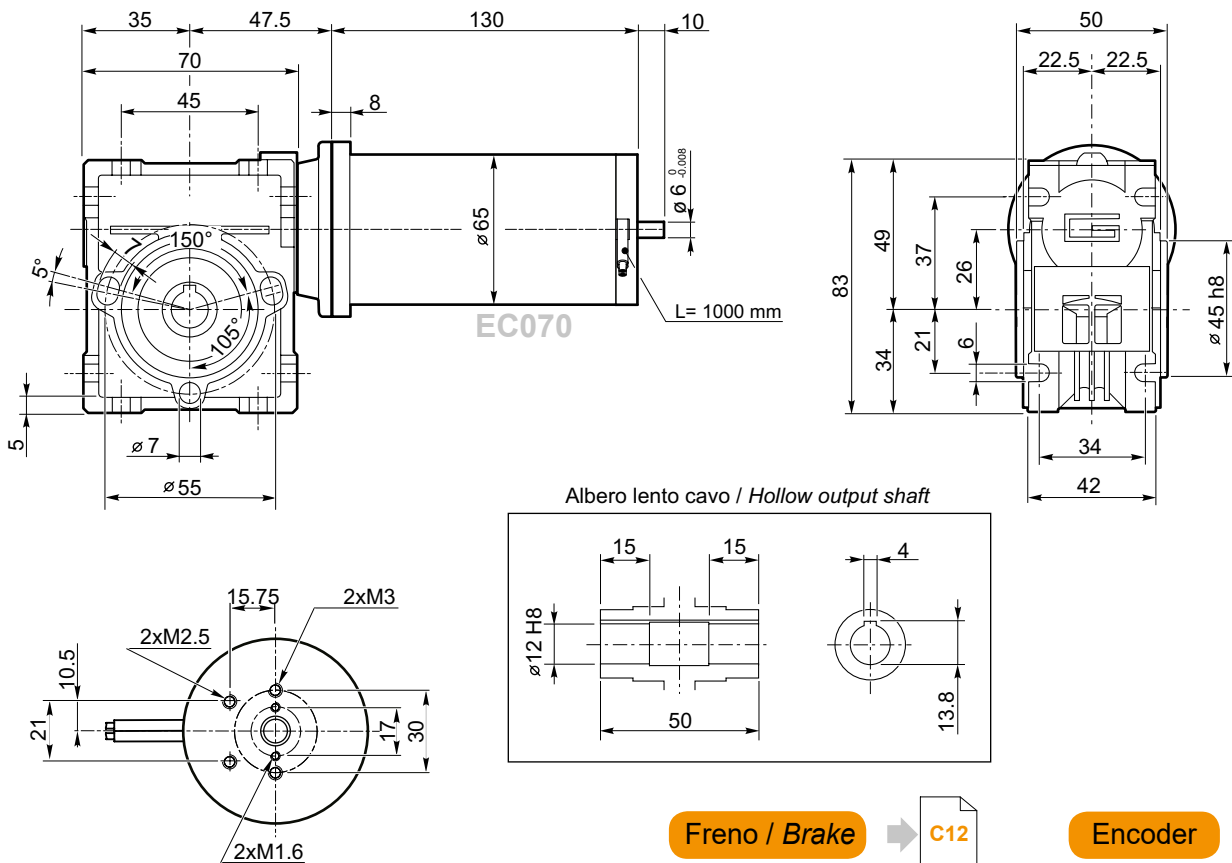

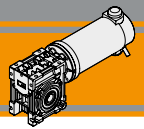

CM026 con motore CC

CM026 with DC motor

CM026 n ₁ =2800 rpm			EC100			
ir	M _n [Nm]	Kg	S1 12/24 V		S2 12/24 V	
			[Nm]	[rpm]	[Nm]	[rpm]
5	10	0.8	1.38	600	1.92	600
7.5	11		2.03	400	2.81	400
10	11		2.63	300	3.65	300
15	11		3.86	200	5.36	200
20	11		4.96	150	6.88	150
30	12		6.79	100	9.42	100
40	11		8.43	75	11.69	75
50	10		9.92	60	13.76	60
60	9		11.16	50	15.48	50

Nota: le caselle in colore grigio indicano il superamento della coppia massima sopportata dal riduttore per il servizio in S1.
N.B.: boxes in grey indicate that maximum torque withstood by gear reducer for service in S1 is exceeded.

Tipo Type	Servizio Duty	P _n [W]	V [V]	I [A]	IC	FF	M _n [Nm]	n ₁ [rpm ¹]	IP	Kg
EC100.120	S1	100	12	12	F	1	0.31	3000	40	2.7
	S2 25'	140		16.8			0.43			
EC100.240 EC100.24E	S1	100	24	6			0.31		20	
	S2 25'	140		8.4			0.43			

Azionamenti
Drives

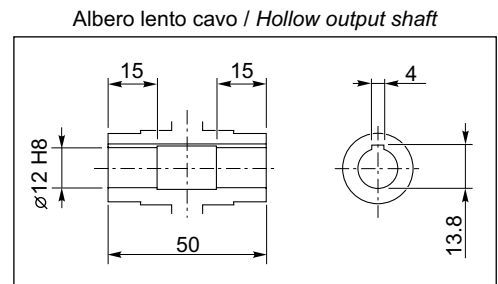
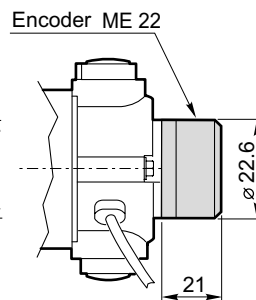
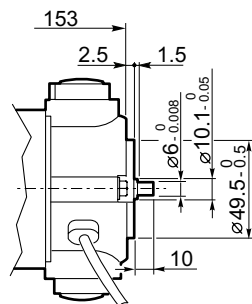
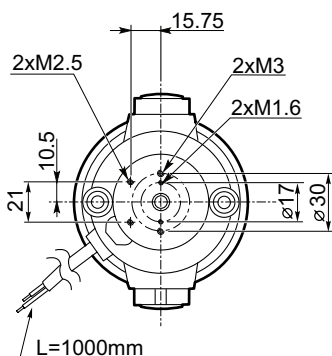
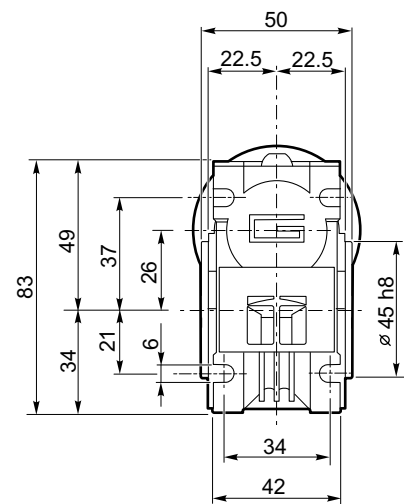
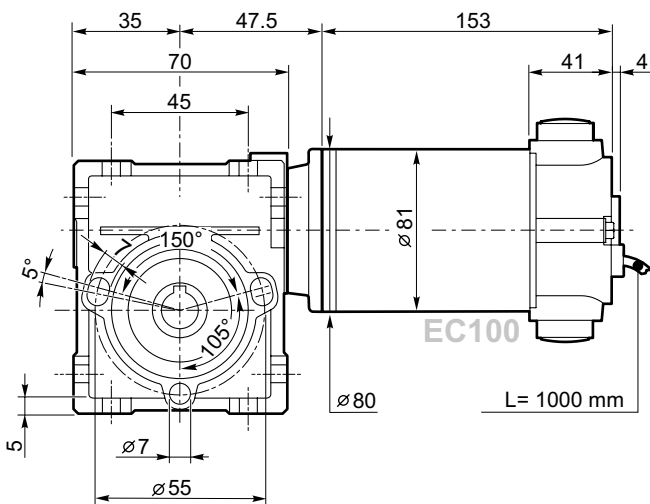

Freno / Brake



Encoder

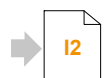

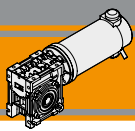

Micro motoriduttori CC a vite senza fine DC Micro wormgearmotors

CM030 con motore CC

CM030 with DC motor

CM030 n ₁ =3000 rpm			EC100			
i _r	M _n [Nm]	Kg	S1 12/24 V		S2 12/24 V	
			[Nm]	[rpm]	[Nm]	[rpm]
5	13	1.2	1.4	600	1.9	600
7.5	15		2	400	2.8	400
10	16		2.7	300	3.7	300
15	16		3.9	200	5.4	200
20	14		5	150	6.9	150
25	15		6	120	8.3	120
30	18		6.9	100	9.6	100
40	16		8.7	75	12.1	75
50	15		10	60	13.9	60
60	14		11.5	50	16.0	50
80	12		14.1	37.5	19.6	37.5
100	11		16.1	30	22.3	30

Nota: le caselle in colore grigio indicano il superamento della coppia massima sopportata dal riduttore per il servizio in S1.
N.B.: boxes in grey indicate that maximum torque withstood by gear reducer for service in S1 is exceeded.

Tipo Type	Servizio Duty	P _n [W]	V [V]	I [A]	IC	FF	M _n [Nm]	n ₁ [rpm ¹]	IP	Kg
EC100.120	S1	100	12	12	F	1	0.31	3000	40	2.7
	S2 25'	140		16.8			0.43			
EC100.240	S1	100	24	6			0.31			
EC100.24E	S2 25'	140		8.4			0.43		20	

Azionamenti
Drives

H2

Freno / Brake

C12

Encoder

I2

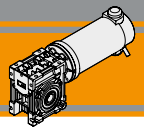

CM030 con motore CC

CM030 with DC motor

CM030 n ₁ =3000 rpm			EC180			
i _r	M _n [Nm]	Kg	S1 12/24 V		S2 12/24 V	
			[Nm]	[rpm]	[Nm]	[rpm]
5	13	1.2	2.6	600	3.6	600
7.5	15		3.7	400	5.2	400
10	16		5.0	300	7.0	300
15	16		7.2	200	10.1	200
20	14		9.2	150	12.9	150
25	15		11.0	120	15.5	120
30	18		12.7	100	17.8	100
40	16		16.0	75	22.5	75
50	15		18.4	60	25.8	60
60	14		21.1	50	29.7	50
80	12		25.9	37.5	36.4	37.5
100	11		29.6	30	41.5	30

Nota: le caselle in colore grigio indicano il superamento della coppia massima sopportata dal riduttore per il servizio in S1.
N.B.: boxes in grey indicate that maximum torque withstood by gear reducer for service in S1 is exceeded.

Nota: su rapporti 60, 80 e 100 non è possibile montare motore EC180.24E
Note: on ratio 60, 80 and 100 is not possible to assembly motor EC180.24E

Tipo Type	Servizio Duty	P _n [W]	V [V]	I [A]	IC	FF	M _n [Nm]	n ₁ [rpm ¹]	IP	Kg
EC180.120	S1	180	12	21.5	F	1	0.57	3000	40	3.4
	S2 25'	250		30			0.8			
EC180.240	S1	180	24	10.8			0.57			
EC180.24E	S2 25'	250		15			0.8		20	

Azionamenti Drives

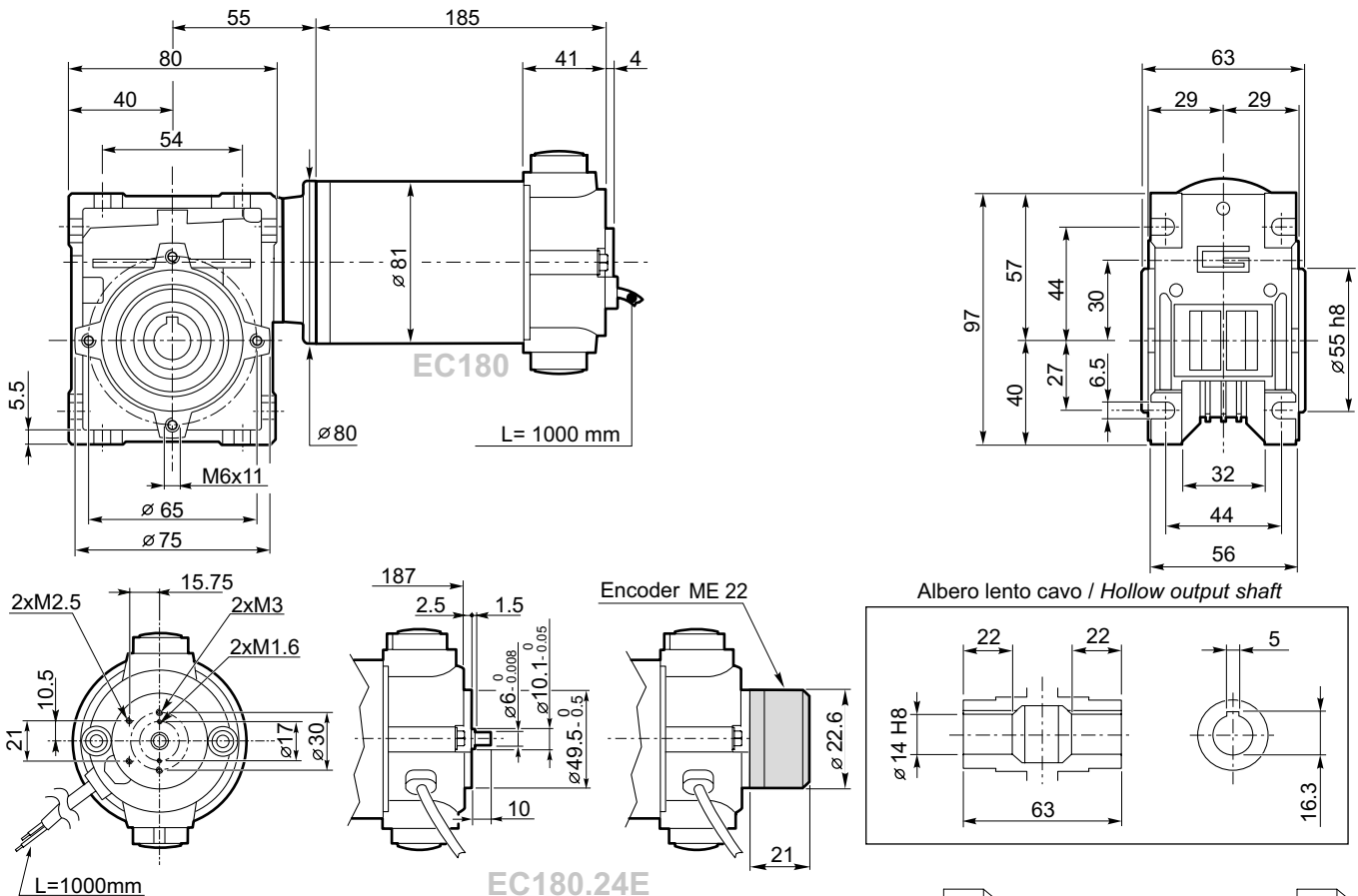

Freno / Brake



Encoder



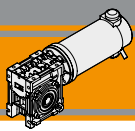

Dimensioni

Dimensions

CM.../... F... Flange uscita / Output flanges

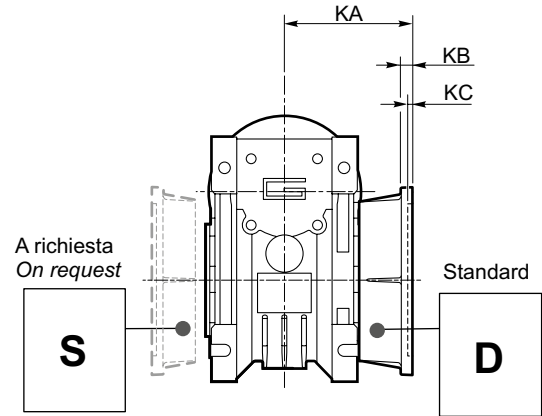
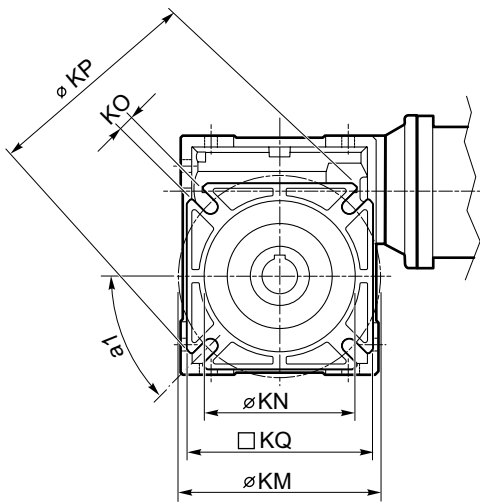

CM	CM..F								
	a1	KA	KB	KC	KM	KN H8	KO	KP	KQ
026	45°	45	6	4.5	55-69	40	6.5(n.4)	75	70
030	45°	54.5	6	4	68	50	6.5(n.4)	80	70

Opzioni

Options

VS - Vite sporgente / Extended input shaft

SC - Safety cover

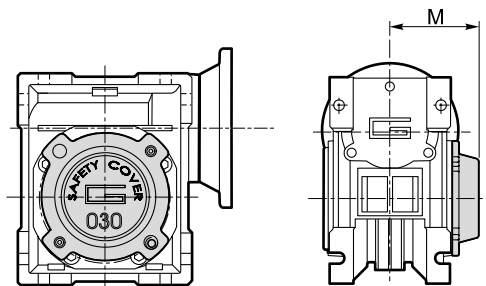
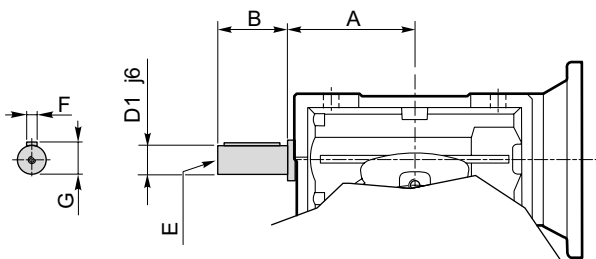

	A	B	D ₁ j6	E	F	G
CM 030	45	20	9	M4	3	10.2

	M
CM 030	47

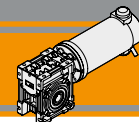

Accessori

Accessories

Albero lento

Output shaft

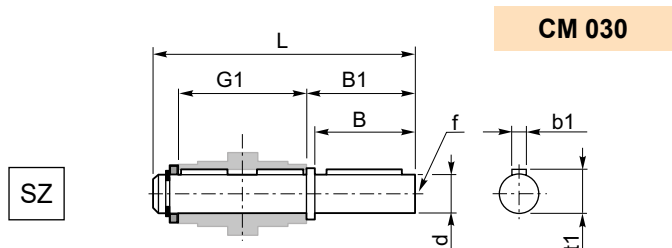
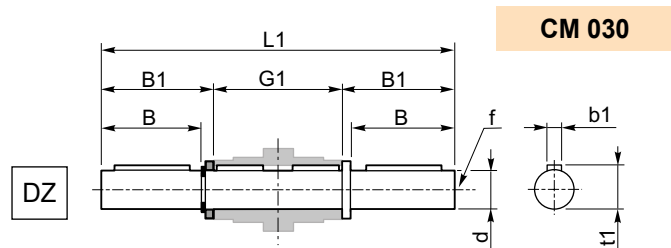

	d h7	B	B1	G1	L	L1	f	b1	t1
CM 030	14	30	32.5	63	102	128	M6	5	16

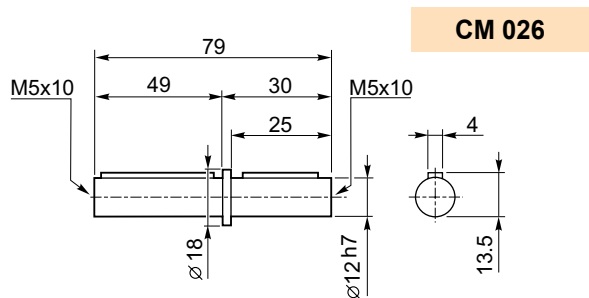

Braccio di reazione

Torque arm

	K1	G	KG	KH	R
CM 030	85	14	23	8	15

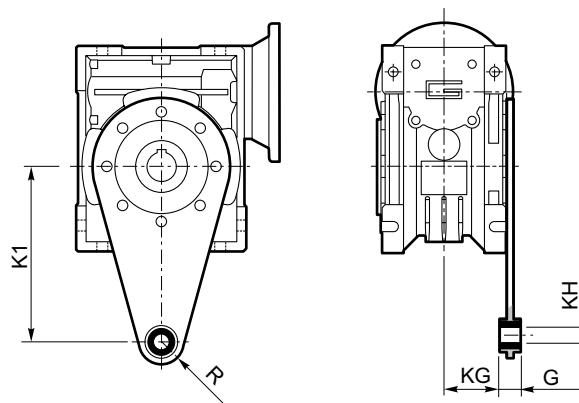

DC
CM

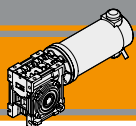

Freno

Brake

Freno / Brake

Freno con leva di sblocco/ Brake with hand release

EC050...BR
EC070...BR

EC050...BRL
EC070...BRL

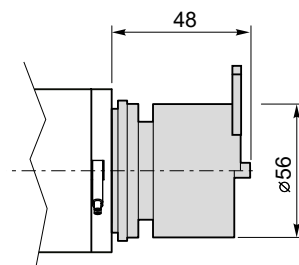
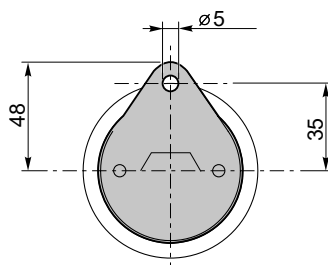
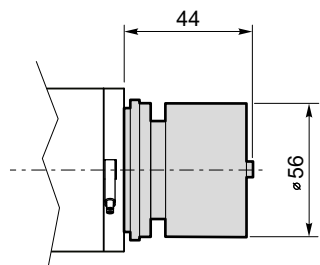

	P_n [W]	V [V]	M_n [Nm]	n₁ [min ⁻¹]
Caratteristiche del freno / Break features	14	12	2	3000
		24		

EC100.24E BR
EC180.24E BR

EC100.24E BRL
EC180.24E BRL

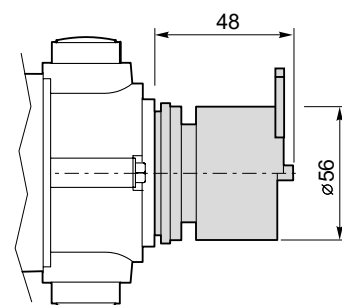
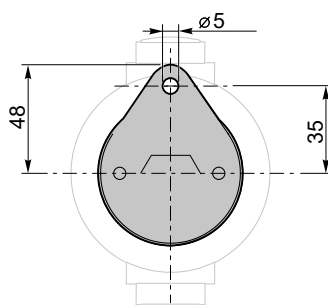
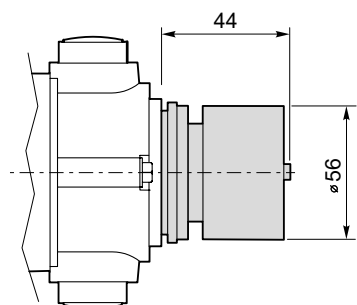

	P_n [W]	V [V]	M_n [Nm]	n₁ [min ⁻¹]
Caratteristiche del freno / Break features	14	12	2	3000
		24		

Micro motoriduttori AC a vite senza fine AC Micro wormgearmotors

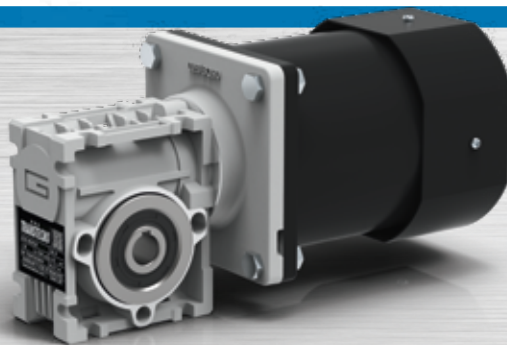

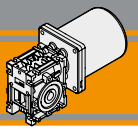

Indice	Index	Pag. Page
Caratteristiche tecniche	<i>Technical features</i>	D2
Designazione	<i>Classification</i>	D2
Simbologia	<i>Symbols</i>	D2
Lubrificazione	<i>Lubrication</i>	D3
Carichi radiali	<i>Radial loads</i>	D3
Dati di dentatura	<i>Toothing data</i>	D4
Rendimento	<i>Efficiency</i>	D4
CM026 con motore AC	<i>CM026 with AC motor</i>	D5
CM030 con motore AC	<i>CM030 with AC motor</i>	D7
Dimensioni	<i>Dimensions</i>	D8
Opzioni	<i>Options</i>	D9
Accessori	<i>Accessories</i>	D9

Questa sezione annulla e sostituisce ogni precedente edizione o revisione. Qualora questa sezione non Vi sia giunta in distribuzione controllata, l'aggiornamento dei dati ivi contenuto non è assicurato. **In tal caso la versione più aggiornata è disponibile sul nostro sito internet www.intecno-srl.com**

*This section replaces any previous edition and revision. If you obtained this catalogue other than through controlled distribution channels, the most up to date content is not guaranteed. **In this case the latest version is available on our web site www.intecno-srl.com***

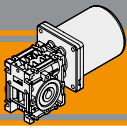

Micro motoriduttori AC a vite senza fine

AC Micro wormgearmotors

Caratteristiche tecniche

Technical features

Le caratteristiche principali dei motoriduttori a vite senza fine CM con motore asincrono CA sono:

The main features of CM wormgearmotors range with asincron AC motor are:

- Alimentazione a corrente alternata trifase 400 Vca - 50Hz e monofase 230 Vca 50 Hz
- Potenze motore disponibili 40W e 60W
- Carcasse dei riduttori in pressofusione di alluminio
- Lubrificazione permanente con olio sintetico
- Elevata affidabilità in ingombri molto ridotti
- Supply voltage three phase 400Vac-50Hz and single phase 230Vca-50Hz
- Motor power available 40W and 60W
- Die-cast aluminum housing for wormgearboxes
- Permanent synthetic oil long-life lubrication
- Reliable and compact

Designazione

Classification

MOTORIDUTTORE / GEARMOTOR								
ACM	060/026	U	10	SZDX	BRSX	90	230/1	VS
Tipo Type	Grandezza Size	Versione Riduttore Gearbox Version	Rapporto Ratio	Albero di uscita Output shaft	Braccio di reazione Torque arm	Angolo Angle	Versione Motore Motor Version	Opzioni Options
	040/026 040/030 060/026 060/030	U FD FS	Vedere tabella See tables	SZDX SZSX DZ	BRDX BRSX	0° 90° 180° 270°	230/1 400/3 230/3 a richiesta on request	VS

Versione Riduttore
Gearbox Version

Albero di uscita
Output shaft

Braccio di reazione
Torque arm

Angolo
Angle

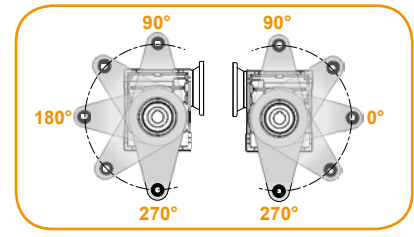
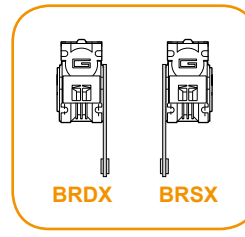
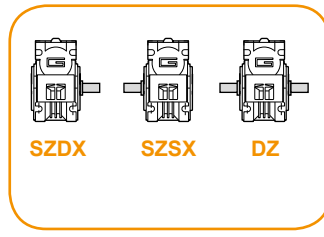
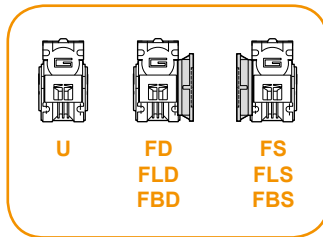

Simbologia

Symbols

n_1	[min^{-1}]	Velocità in ingresso / Input speed	R_d	%	Rendimento dinamico / Dynamic efficiency
n_2	[min^{-1}]	Velocità in uscita / Output speed	A_2	[N]	Carico assiale ammissibile in uscita / Permitted output axial load
i		Rapporto di riduzione / Ratio	R_s	%	Rendimento statico / Static efficiency
P_1	[kW]	Potenza in entrata / Input power	R_2	[N]	Carico radiale ammissibile in uscita / Permitted output radial load
M_n	[Nm]	Coppia in uscita in funzione di P_1 / Output torque referred to P_1	Z		Numero di principi della vite / Worm starts
sf		Fattore di servizio / Service factor	β		Angolo d'elica / Helix angle

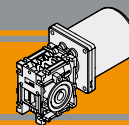

Lubrificazione

Lubrication

I riduttori a vite senza fine della serie CM026 e CM030 sono lubrificati a vita con olio sintetico di viscosità 320 e possono essere installati in qualunque posizione di montaggio. Temperatura ambiente 0 ÷ 40 °C (in assenza di congelamento ed in assenza di condensa). Per temperature diverse, contattare nostro UT.

Permanent synthetic oil long-life lubrication allow to use CM026 and CM030 wormgearbox range in all mounting position. Ambient temperature 0 ÷ 40 °C (in the absence of freezing and condensation). For temperature outside this range please contact our technical dept.

Quantità di olio (litri) / Oil quantity (litres)						
	B3	B8	B6	B7	V5	V6
CM026	0.015					
CM030	0.03					

Carichi radiali

Radial loads

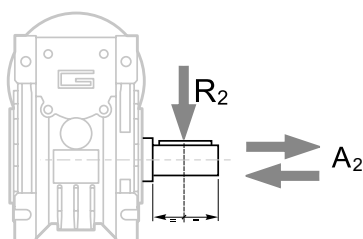

$A_2 = R_2 \times 0.2$

n ₂ [min ⁻¹]	R ₂ [N]	
	CM026	CM030
187	400	674
140	490	743
93	580	851
70	610	936
56	610	1008
47	610	1069
35	610	1179
28	610	1270
23	610	1356
18	610	1471
14	610	1600

Quando il carico radiale risultante non è applicato sulla mezzeria dell'albero occorre calcolare quello effettivo con la seguente formula:

When the resulting radial load is not applied on the centre line of the shaft it is necessary to calculate the effective load with the following formula:

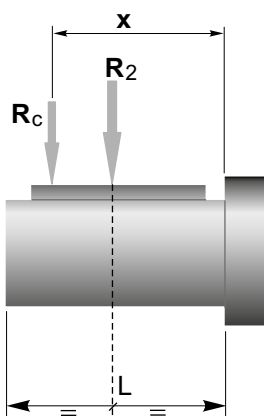

$$R_c = \frac{R_2 \cdot a}{(b + x)} \leq R_{2MAX}$$

$$R \leq R_c$$

a, b = valori riportati nella tabella
a, b = values given in the table

	CM	
	026	030
a	56	65
b	43	50
R _{2MAX}	610	1600

AC
CM

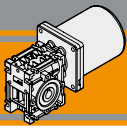

Micro motoriduttori AC a vite senza fine AC Micro wormgearmotors

CM026 con motore CA

CM026 with AC motor

CM026 n ₁ =1300 rpm			AC040	
ir	M _n [Nm]	Kg	[Nm]	[rpm]
5	13	3.4	1.3	260
7.5	14		1.9	173
10	14		2.4	130
15	14		3.4	87
20	14		4.3	65
30	15		5.8	43
40	14		7.2	33
50	13		8.4	26
60	12		9.3	22

Tipo Type	Servizio Duty	P _n [W]	V [V]	I _n [A]	IC	F [Hz]	M _n [Nm]	n ₁ [rpm]	IP	I _s / I _n	M _s / M _n	Cap [μF]
AC040 230/1	S1	40	230	0.43	B	50	0.3	1300	20	1.8	0.71	2.5
AC040 400/3	S1	40	400	0.30						2.3	3	-

ACM040/026 U

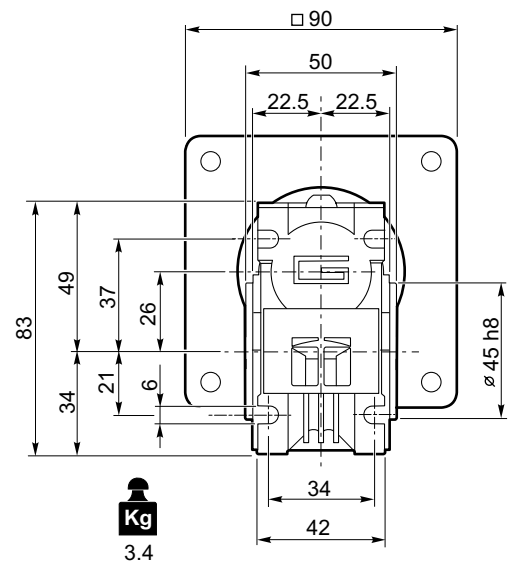
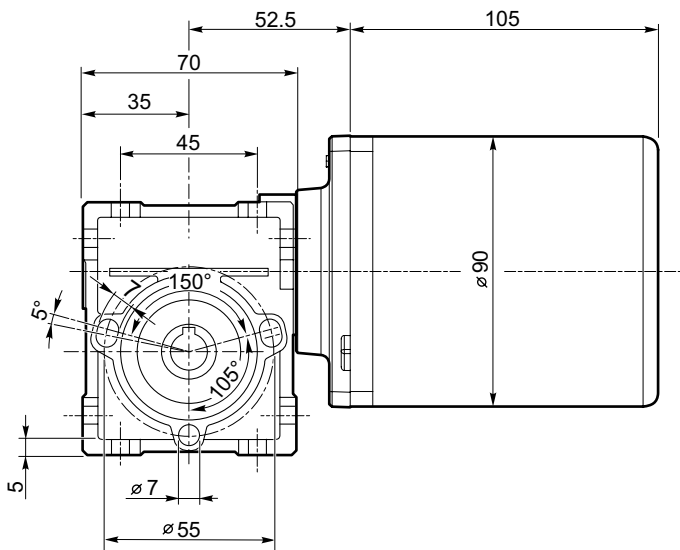

Albero lento cavo / Hollow output shaft

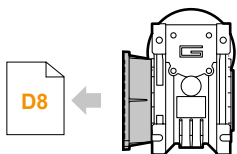
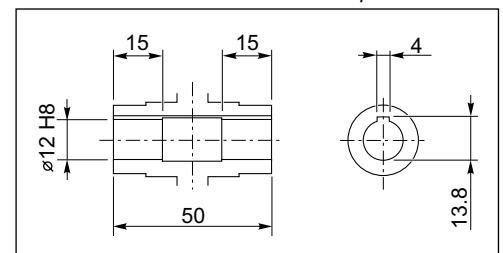

ACM040/026 F

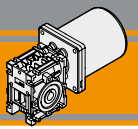

CM026 con motore CA

CM026 with AC motor

CM026 n ₁ =1300 rpm			AC060	
ir	M _n [Nm]	Kg	[Nm]	[rpm]
5	13	3.4	1.9	260
7.5	14		2.8	173
10	14		3.7	130
15	14		5.2	87
20	14		6.5	65
30	15		8.7	43
40	14		10.8	33
50	13		12.6	26
60	12		14	22

Nota: le caselle in colore grigio indicano il superamento della coppia massima sopportata dal riduttore per il servizio in S1.
N.B.: boxes in grey indicate that maximum torque withstood by gear reducer for service in S1 is exceeded.

Tipo Type	Servizio Duty	P _n [W]	V [V]	I _n [A]	IC	F [Hz]	M _n [Nm]	n ₁ [rpm]	IP	I _s / I _n	M _s / M _n	Cap [μF]
AC060 230/1	S1	60	230	0.65	B	50	0.44	1300	20	1.7	0.6	3.5
AC060 400/3	S1	60	400	0.35						2.5	3.5	-

ACM060/026 U

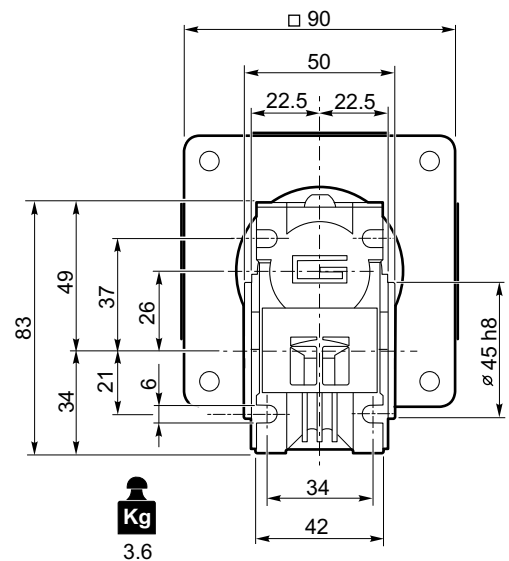
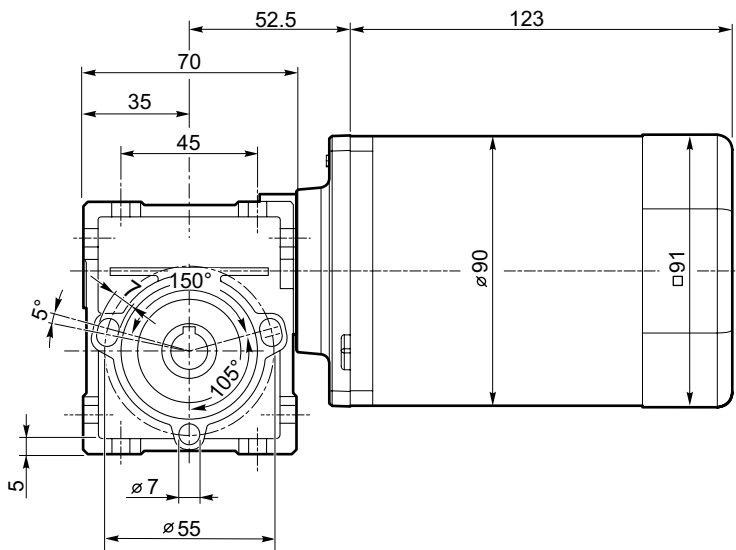

Albero lento cavo / Hollow output shaft

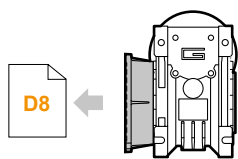
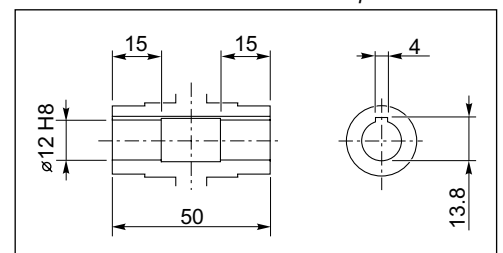

ACM060/026 F

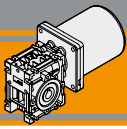

Micro motoriduttori AC a vite senza fine AC Micro wormgearmotors

CM030 con motore CA

CM030 with AC motor

CM030 $n_1=1300$ rpm			AC040	
ir	M_n [Nm]	Kg	[Nm]	[rpm]
5	18	2.7	1.3	260
7.5	20		1.9	173
10	21		2.5	130
15	21		3.5	87
20	19		4.4	65
25	20		5.3	52
30	22		5.9	43
40	20		7.3	33
50	19		8.5	26
60	17		9.7	22
80	15		11.3	16
100	14		12.6	13

Tipo Type	Servizio Duty	P_n [W]	V [V]	I_n [A]	IC	F [Hz]	M_n [Nm]	n_1 [rpm]	IP	I_s / I_n	M_s / M_n	Cap [μ F]
AC040 230/1	S1	40	230	0.43	B	50	0.3	1300	20	1.8	0.71	2.5
AC040 400/3	S1	40	400	0.30						2.3	3	-

ACM040/030 U

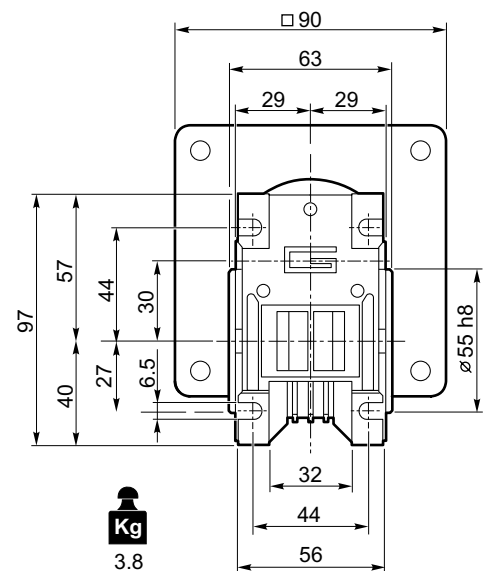
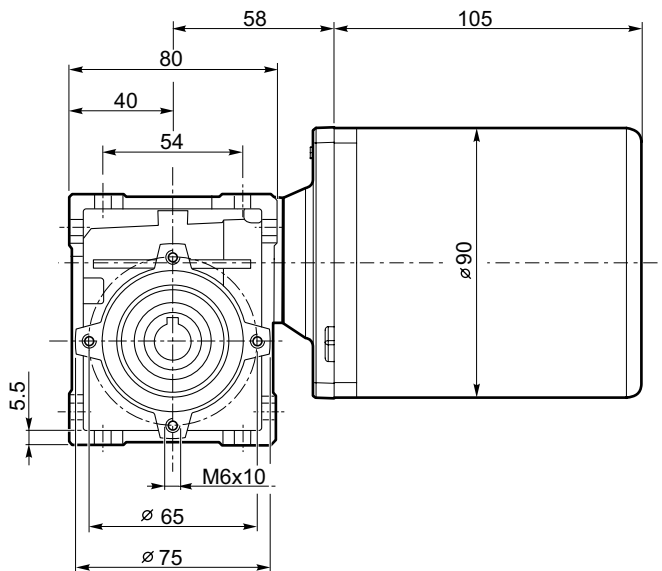

Albero lento cavo / Hollow output shaft

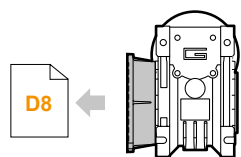

ACM040/030 F

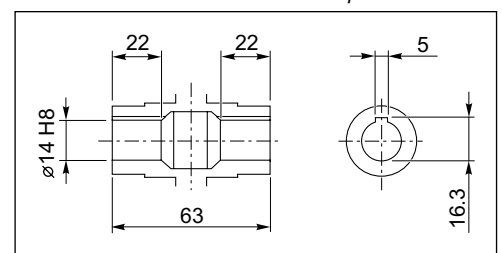

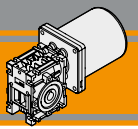

CM030 con motore CA

CM030 with AC motor

CM030 n ₁ =1300 rpm			AC060	
ir	M _n [Nm]	Kg	[Nm]	[rpm]
5	18	4	1.9	260
7.5	20		2.8	173
10	21		3.7	130
15	21		5.2	87
20	19		6.6	65
25	20		7.9	52
30	22		8.9	43
40	20		10.9	33
50	19		12.8	26
60	17		14.5	22
80	15		16.9	16
100	14		16	13

Nota: le caselle in colore grigio indicano il superamento della coppia massima sopportata dal riduttore per il servizio in S1.
N.B.: boxes in grey indicate that maximum torque withstood by gear reducer for service in S1 is exceeded.

Tipo Type	Servizio Duty	P _n [W]	V [V]	I _n [A]	IC	F [Hz]	M _n [Nm]	n ₁ [rpm]	IP	I _s / I _n	M _s / M _n	Cap [μF]
AC060 230/1	S1	60	230	0.65	B	50	0.44	1300	20	1.7	0.6	3.5
AC060 400/3	S1	60	400	0.35						2.5	3.5	-

ACM060/030 U

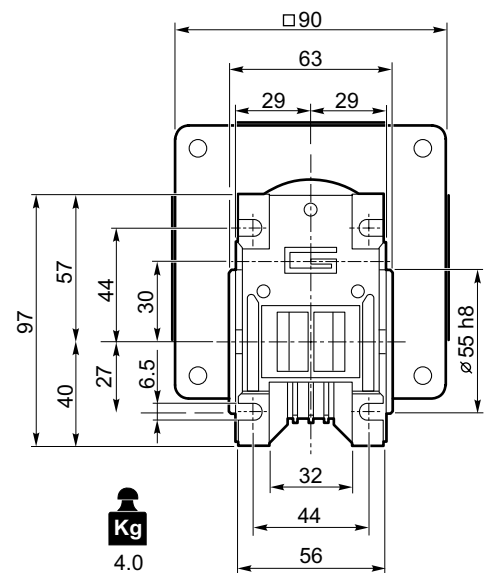
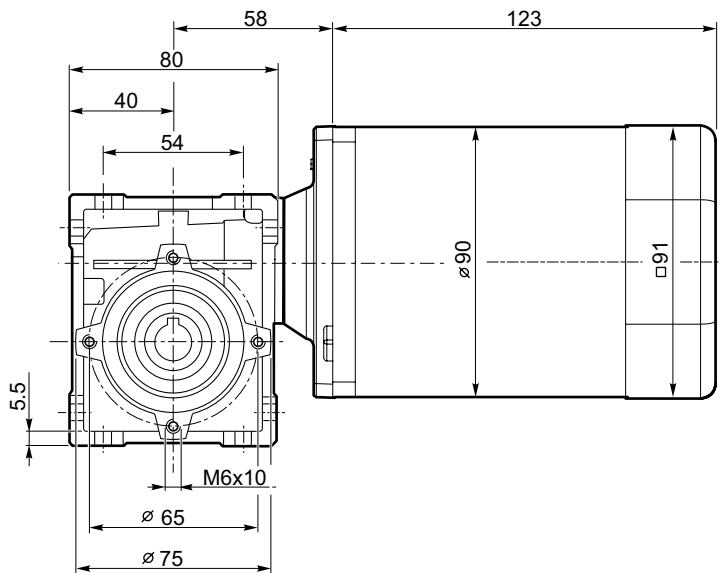

Albero lento cavo / Hollow output shaft

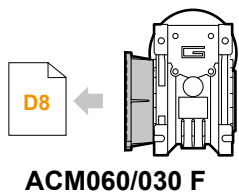
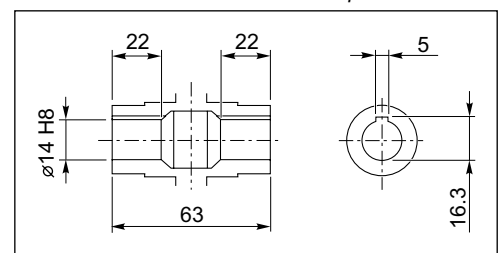

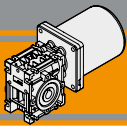

Dimensioni

Dimensions

ACM.../026 F... Flange uscita / Output flanges

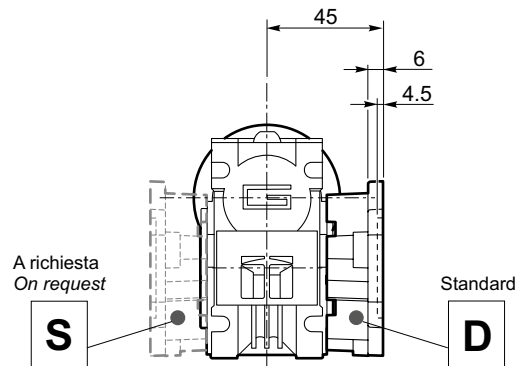
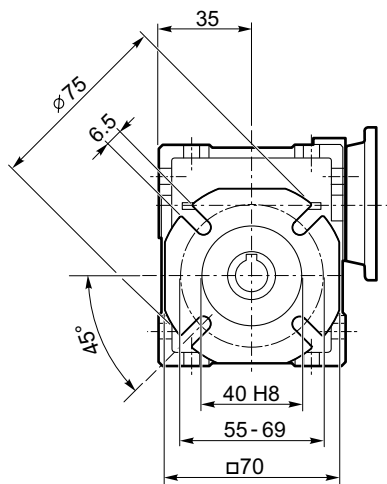

ACM.../030 F... Flange uscita / Output flanges

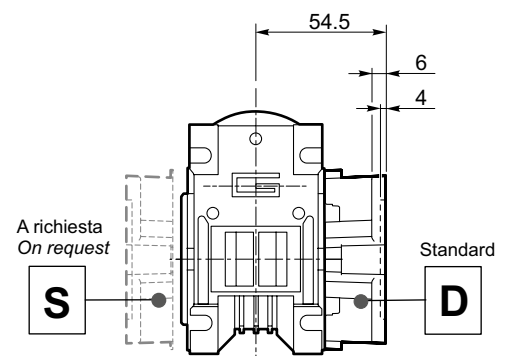
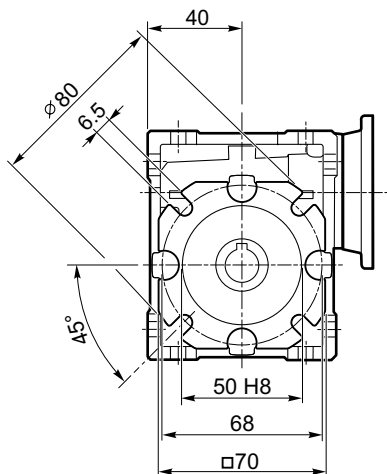

Motori brushless CC Brushless DC motors

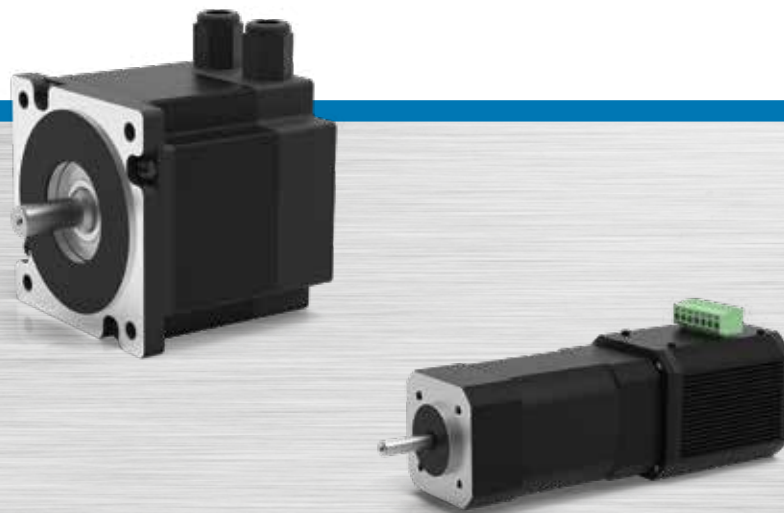

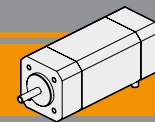

	Indice	Index	Pag. Page
	Caratteristiche tecniche	<i>Technical features</i>	E2
	Grado di protezione IP	<i>IP enclosures protection indexes</i>	E2
	Classe di isolamento termico	<i>Insulation class</i>	E2
	Tipi di servizio IEC	<i>IEC duty cycle ratings</i>	E2
	Legenda / Glossario dei grafici	<i>Key / Diagram Glossary</i>	E3
	Formule utili	<i>Useful formulas</i>	E3
BL005.240	Specifiche costruttive	<i>General features</i>	E4
BL005.240-IE	Prestazioni	<i>Performances</i>	E4
	Dimensioni	<i>Dimensions</i>	E5
	Diagramma dei collegamenti	<i>Connection diagram</i>	E5
BL012.240	Specifiche costruttive	<i>General features</i>	E6
BL012.240-IE	Prestazioni	<i>Performances</i>	E6
	Dimensioni	<i>Dimensions</i>	E7
	Diagramma dei collegamenti	<i>Connection diagram</i>	E7
BL018.240	Specifiche costruttive	<i>General features</i>	E8
BL018.240-IE	Prestazioni	<i>Performances</i>	E8
	Dimensioni	<i>Dimensions</i>	E9
	Diagramma dei collegamenti	<i>Connection diagram</i>	E9
BL025.24E	Specifiche costruttive	<i>General features</i>	E10
	Prestazioni	<i>Performances</i>	E10
	Dimensioni	<i>Dimensions</i>	E11
	Diagramma dei collegamenti	<i>Connection diagram</i>	E11
BL032.240	Specifiche costruttive	<i>General features</i>	E12
BL032.240-IE	Prestazioni	<i>Performances</i>	E12
	Dimensioni	<i>Dimensions</i>	E13
	Diagramma dei collegamenti	<i>Connection diagram</i>	E13
BL043.240	Specifiche costruttive	<i>General features</i>	E14
BL043.240-IE	Prestazioni	<i>Performances</i>	E14
	Dimensioni	<i>Dimensions</i>	E15
	Diagramma dei collegamenti	<i>Connection diagram</i>	E15
BL070.48E	Specifiche costruttive	<i>General features</i>	E16
	Prestazioni	<i>Performances</i>	E16
	Dimensioni	<i>Dimensions</i>	E17
	Diagramma dei collegamenti	<i>Connection diagram</i>	E17

Questa sezione annulla e sostituisce ogni precedente edizione o revisione. Qualora questa sezione non Vi sia giunta in distribuzione controllata, l'aggiornamento dei dati ivi contenuto non è assicurato. **In tal caso la versione più aggiornata è disponibile sul nostro sito internet www.intecno-srl.com**

This section replaces any previous edition and revision. If you obtained this catalogue other than through controlled distribution channels, the most up to date content is not guaranteed. In this case the latest version is available on our web site www.intecno-srl.com

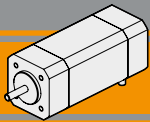

Caratteristiche tecniche

Technical features

I motori brushless cc della serie BL vengono realizzati in 5 taglie con coppie da 22 mNm a 0.7 Nm, e possono essere forniti con driver integrato (versione IE) o con driver esterno. I vantaggi di utilizzare i motori brushless anziché i tradizionali motori cc a spazzole, sono i seguenti:

- Lunga durata nel tempo
- Elevata efficienza
- Commutazione elettronica e controllo del motore tramite sensori digitali (encoder, resolver ecc..)
- Ampio campo di regolazione della velocità
- Mancanza di manutenzione

I motori della serie BL sono estremamente compatti e grazie al basso momento di inerzia offrono una elevata prestazione dinamica, ed inoltre sono economici in quanto dotati di sensori di Hall (anziché encoder o resolver).

Le 3 fasi dell'avvolgimento del motore sono a bassa tensione 24V / 36V / 48V e quindi offrono maggiori garanzie in termini di sicurezza dell'impianto, soprattutto nelle applicazioni dove l'operatore può essere a contatto con il motore stesso.

Inoltre l'utilizzo dell'elettronica integrata, **versione opzionale IE**, per il controllo della velocità permette di semplificare in modo sostanziale il cablaggio dell'impianto, riducendo anche gli spazi nei quadri di comando.

Brushless DC motors from the BL range are available in 5 sizes with torque from 22 mNm to 0.7Nm and they can be supplied with either an integrated (version IE) or external driver.

The advantages of using brushless motors instead of traditional DC brush motors are the following:

- Longer life time
- Higher efficiency
- Electronic commutation and control of the motor via digital sensors (encoder, resolver etc.)
- Wide speed range
- Maintenance free

BL motors have a compact design and thanks to low inertia they have high performances and are a low cost solution already including Hall sensors, as opposed to an encoder or resolver.

The 3 phase windings of the motor have a low voltage of 24/36/48 V and so these motors are safer to use when a machine operator has direct contact with them.

Furthermore, by using the integrated speed controller, **optional IE solution**, the cables of the equipment can be simplified taking up less space in the electric cabinet.

Grado di protezione IP

IP enclosures protection indexes

Indica il grado di isolamento meccanico del corpo motore.

1^a cifra protezione alla penetrazione di corpi solidi.

2^a cifra protezione contro la penetrazione d'acqua.

Indicates the degree of mechanical insulation of the motor body. 1st figure indicating level of protection against the penetration of solid bodies.

2nd figure: indicating degree to which the motor is waterproof.

2	Protetto da corpi solidi superiori a Ø 12 mm. <i>Protected against solid matters (over Ø 12 mm)</i>	0	Non protetto / No protection
3	Protetto da corpi solidi superiori a Ø 2,5 mm. <i>Protected against solid matters (over Ø 2,5 mm)</i>		

Classe di isolamento termico

Insulation class

Classe / Class	Δ t °C Temp. ambiente: 40°C Ambient temperature: 40°C
B	90°C

Tipi di servizio IEC

IEC duty cycle ratings

S1	Servizio continuo. Funzionamento a carico costante per una durata sufficiente al raggiungimento dell'equilibrio termico.	Continuous duty. The motor works at a constant load for enough time to reach temperature equilibrium
S2	Servizio di durata limitata. Funzionamento a carico costante per una durata inferiore a quella necessaria al raggiungimento dell'equilibrio termico, seguito da un periodo di riposo tale da riportare il motore alla temperatura ambiente.	Short time duty. The motor works at a constant load, but not long enough to reach temperature equilibrium, and the rest periods are long enough for the motor to reach ambient temperature.
S3	Servizio periodico intermittente. Sequenze di cicli identici di marcia e di riposo a carico costante, senza raggiungimento dell'equilibrio termico. La corrente di spunto ha effetti trascurabili sul surriscaldamento del motore.	Intermittent periodic duty. Sequential, identical run and rest cycles with constant load. Temperature equilibrium is never reached. Starting current has little effect on temperature rise.

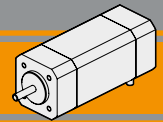

Legenda / Glossario dei grafici

Key / Diagram Glossary

Dato un motore brushless cc, la velocità di rotazione è funzione lineare della coppia; così pure la corrente assorbita è una funzione lineare della coppia. Velocità e corrente variano in maniera sensibile al variare del carico.

With a brushless motor, the rotational speed is a linear function of the torque. In the same way, the absorbed current is also a linear function of the torque. Speed and current change a lot against applied torque.

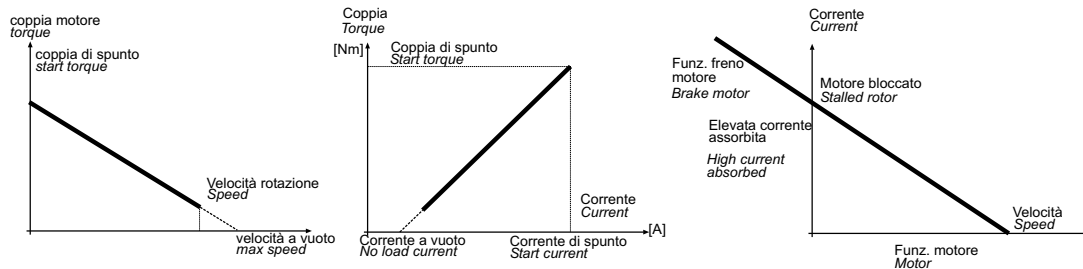

La potenza utile (potenza all' albero) si ricava dalla formula:

$$P_n [W] = M_n \cdot S = \frac{2\pi}{60} \cdot n_1 \cdot M_n$$

The output power is calculated using the formula:

$$P_n [W] = M_n \cdot S = \frac{2\pi}{60} \cdot n_1 \cdot M_n$$

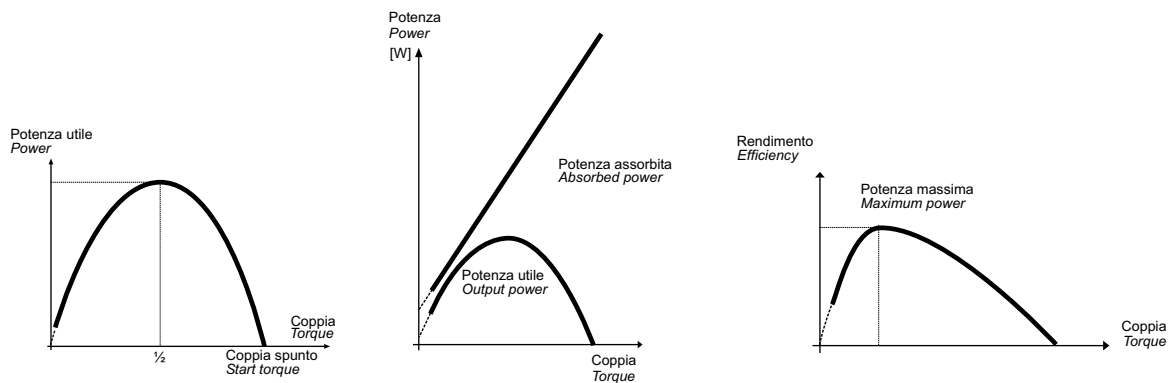

Poiché la tensione di alimentazione è costante mentre la corrente è linearmente crescente al crescere della coppia, l'andamento della potenza assorbita è una retta crescente. Dal rapporto tra la potenza meccanica e la potenza assorbita si ottiene il grafico dell'efficienza.

Since the supply voltage is constant, whereas the current increases in a linear manner as the torque increases, the absorbed power trend is a straight line going up. Efficiency is shown from the ratio between the output power and the absorbed power.

Formule utili

Useful formulas

$$\eta = \frac{P_n}{P_a}$$

$$P_a = V \cdot I$$

$$P_n = V \cdot I \cdot \eta$$

$$P_n = M_n \cdot S_v$$

$$S_v = \frac{n_1}{9.55}$$

$$\eta = \frac{P_n}{P_a}$$

$$P_a = V \cdot I$$

$$P_n = V \cdot I \cdot \eta$$

$$P_n = M_n \cdot S_v$$

$$S_v = \frac{n_1}{9.55}$$

$$[HP] \cdot 746 = [W]$$

Esempio 2 HP = circa 1500 W.

$$[HP] \cdot 746 = [W]$$

Example 2 HP = approx. 1500 W.

S	—	Servizio	<i>Duty</i>
P_n	[W]	Potenza in uscita	<i>Rated power</i>
P_a	[W]	Potenza assorbita	<i>Absorbed power</i>
M_n	[Nm]	Coppia nominale	<i>Rated torque</i>
V	[V]	Tensione	<i>Voltage</i>
I	[A]	Corrente assorbita	<i>Absorbed current</i>
n₁	[min ⁻¹]	Numero giri motore	<i>Motor speed</i>
S_v	[rad/s]	Velocità angolare	<i>Angular speed</i>
IC	—	Classe d'isolamento termico	<i>Thermal insulation class</i>
FF	—	Fattore di forma	<i>Form factor</i>
IP	—	Classe di protezione	<i>protection class</i>
η	—	Rendimento	<i>Efficiency</i>
Kg	—	Peso	<i>Weight</i>

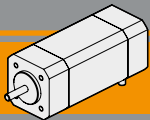

BL005.240 - BL005.240 -IE

Specifiche costruttive

General features

Tipologia di avvolgimento <i>Winding type</i>	Stella <i>Star</i>	Max forza radiale <i>Max radial force</i>	15N @ 10 mm dalla flangia <i>15N @ 10 mm from flange</i>
Angolo sensori Hall <i>HALL effect angle</i>	120 gradi elettrici <i>120 degree electrical angle</i>	Max forza assiale <i>Max axial force</i>	10N
Gioco radiale <i>Radial play</i>	0.02 mm @ 450g	Classe di isolamento termico <i>Insulation class</i>	Classe B <i>Class B</i>
Gioco assiale <i>End play</i>	0.08 mm @ 450g	Isolamento dielettrico <i>Dielectric strength</i>	500Vcc x 1 minuto <i>500 Vdc 1 minute</i>
Scentratura albero <i>Shaft run out</i>	0.025 mm	Resistenza isolamento <i>Insulation resistance</i>	100MΩ minimo, 500Vcc <i>100MΩ min, 500 Vdc</i>

Modello <i>Model</i>	Poli <i>Poles</i>	Fasi <i>Phases</i>	Tensione nominale <i>Rated voltage</i>	Velocità nominale <i>Rated speed</i>	Coppia nominale <i>Rated torque</i>	Potenza nominale <i>Rated power</i>	Coppia di picco <i>Peak torque</i>	Corrente nominale <i>Rated current</i>	Corrente di picco <i>Peak current</i>	Resistenza fase-fase <i>Line to line resistance</i>	Induttanza fase-fase <i>Line to line inductance</i>	Costante di coppia <i>Torque constant</i>	Costante FCEM <i>Back EMF</i>	Inerzia rotore <i>Rotor inertia</i>	Peso <i>Weight</i>	IP
			[V]	[min ⁻¹]	[mNm]	[W]	[mNm]	[A]	[A]	[Ω]	[mH]	[mNm/A]	[V/kRPM]	[gcm ²]	[kg]	
BL005.240	4	3	24	3700	50	16	150	1.0	3	4.2	2.2	50	5.23	5.98	0.208	30
BL005.240-IE	4	3	24	3000	22	7	44	0.55	1.1	9.5	4.8	40	—	5.98	0.220	30

Azionamenti
Drives



Prestazioni

Performances

BL005.240

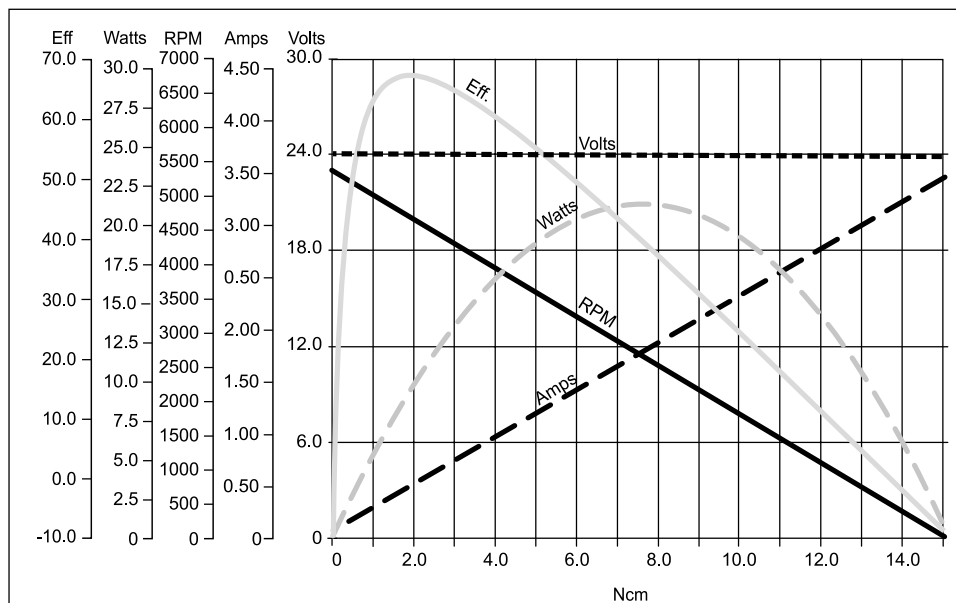

BL005.240-IE

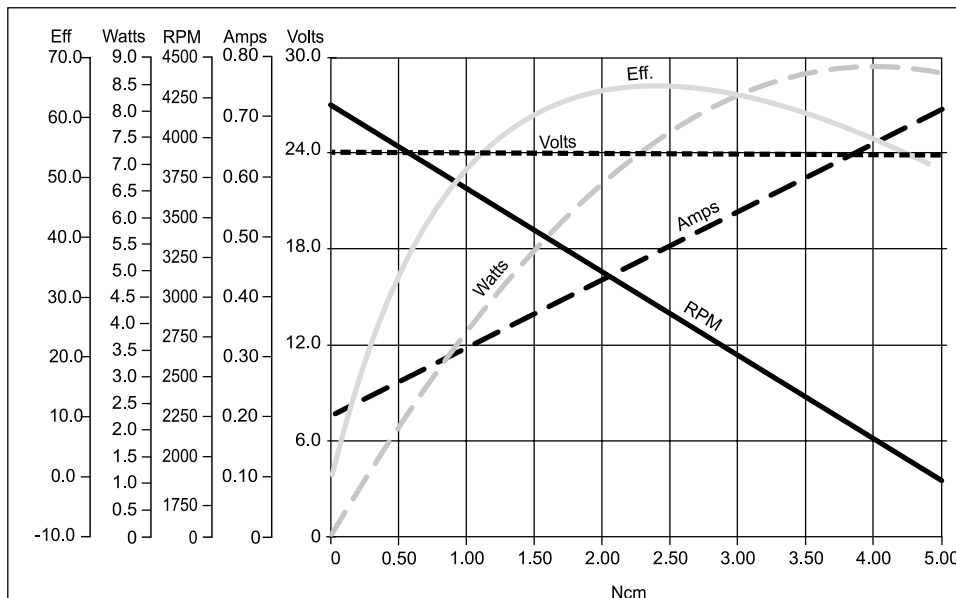

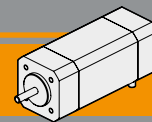

BL005.240 - BL005.240 -IE

Dimensioni

Dimensions

BL005.240

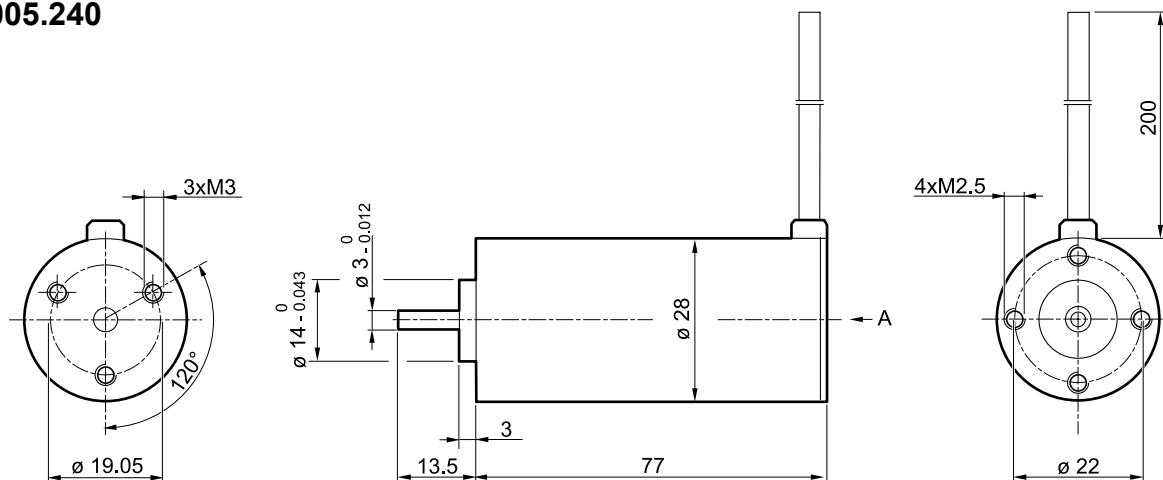

BL005.240-IE



Diagramma dei collegamenti

Connection diagram

BL005.240	
Cavi di potenza Power leads	Descrizione Description
Verde / Green	Fase U / U motor Phase
Rosso / Red	Fase V / V motor Phase
Nero / Black	Fase W / W motor Phase

Cavi di segnale Signal leads	Descrizione Description
Blue	HALL fase U U phase HALL
Arancione / Orange	HALL fase V V phase HALL
Marrone / Brown	HALL fase W W phase HALL
Giallo / Yellow	Alimentazione HALL + 5Vcc Supply voltage for Hall sensors, + 5 Vdc
Bianco / White	Comune per i segnali di HALL Ground for HALL sensors

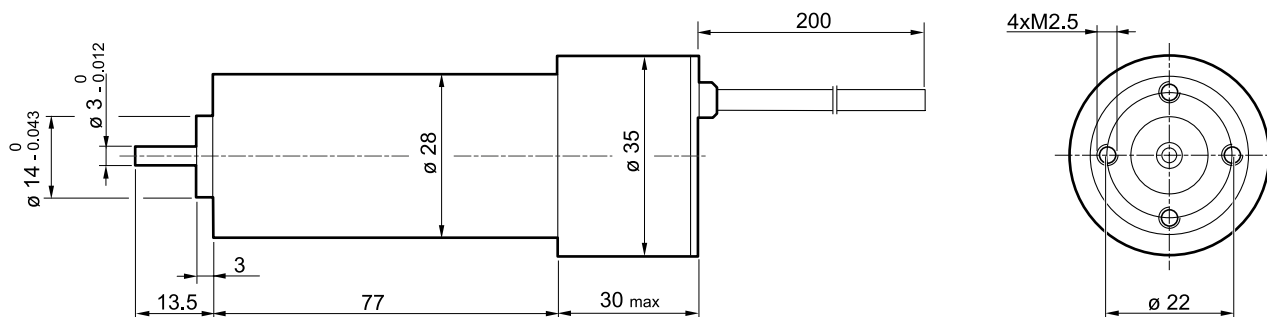
BL005.240-IE	
Cavi Leads	Descrizione Description
Rosso / Red	Alimentazione + 24Vcc Supply voltage +24Vdc
Blue	Comune sia di alimentazione che di segnale Power and signal ground
Bianco / White (*)	Ingresso setpoint di velocità Speed reference signal
Verde / Green	Selezione direzione, aperto oppure chiuso sul comune (cavo blue) Rotation selection, open or closed against the ground (blue)

Nota: Si raccomanda di seguire fedelmente gli schemi di collegamento qui riportati, pericolo di danneggiamento del motore o dell'elettronica.

Note: Pls, follow strictly the above connection diagrams, danger for the motor and the electric control

(*) Senza potenziometro velocità massima. Attivo da 3.5 V (velocità zero) a 1 Vcc (velocità massima). In assenza di alimentazione opportuna per il potenziometro, è possibile usare l'alimentazione 24 Vcc ma limitando superiormente il potenziometro con una resistenza adeguata onde impedire che entrino più di 5 Vcc nel cavo Bianco.

(*) Without speed pot, the motor runs at maximum speed. Motor active in range 3.5 Vdc (zero speed) down to 1 Vdc (max speed). If not available specific voltage, could be applied to speed pot 24 Vdc but using upper resistor to limit max voltage to white lead: no above 5 Vdc, pls.

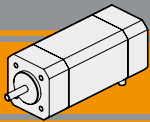

BL012.240 - BL012.240-IE

Specifiche costruttive

General features

Tipologia di avvolgimento <i>Winding type</i>	delta
Angolo sensori Hall <i>HALL effect angle</i>	120 gradi elettrici <i>120 degree electrical angle</i>
Gioco radiale <i>Radial play</i>	0.02 mm @ 450g
Gioco assiale <i>End play</i>	0.08 mm @ 450g
Scentratura albero <i>Shaft run out</i>	0.025 mm

Max forza radiale <i>Max radial force</i>	28N @ 20 mm dalla flangia <i>28N @ 20 mm from flange</i>
Max forza assiale <i>Max axial force</i>	10N
Classe di isolamento termico <i>Insulation class</i>	Classe B <i>Class B</i>
Isolamento dielettrico <i>Dielectric strength</i>	500Vcc x 1 minuto <i>500 Vdc 1 minute</i>
Resistenza isolamento <i>Insulation resistance</i>	100MΩ minimo, 500Vcc <i>100MΩ min, 500 Vdc</i>

Modello <i>Model</i>	Poli <i>Poles</i>	Fasi <i>Phases</i>	Tensione nominale	Velocità nominale	Coppia nominale	Potenza nominale	Coppia di picco	Corrente nominale	Corrente di picco	Resistenza fase-fase	Induttanza fase-fase	Costante di coppia	Costante FCEM	Inerzia rotore	Peso	IP
			Rated voltage	Rated speed	Rated torque	Rated power	Peak torque	Rated current	Peak current	Line to line resistance	Line to line inductance	Torque constant	Back EMF	Rotor inertia	Weight	
			[V]	[min ⁻¹]	[Nm]	[W]	[Nm]	[A]	[A]	[Ω]	[mH]	[Nm/A]	[V/kRPM]	[gcm ²]	[kg]	
BL012.240	8	3	24	4000	0.125	52	0.38	3.5	10.6	0.80	1.2	0.0355	3.72	48	0.45	30
BL012.240-IE	8	3	24	4000	0.125	52	0.25	3.5	7.1	0.80	1.2	0.0355	3.72	48	0.57	30

Azionamenti
Drives



Prestazioni

Performances

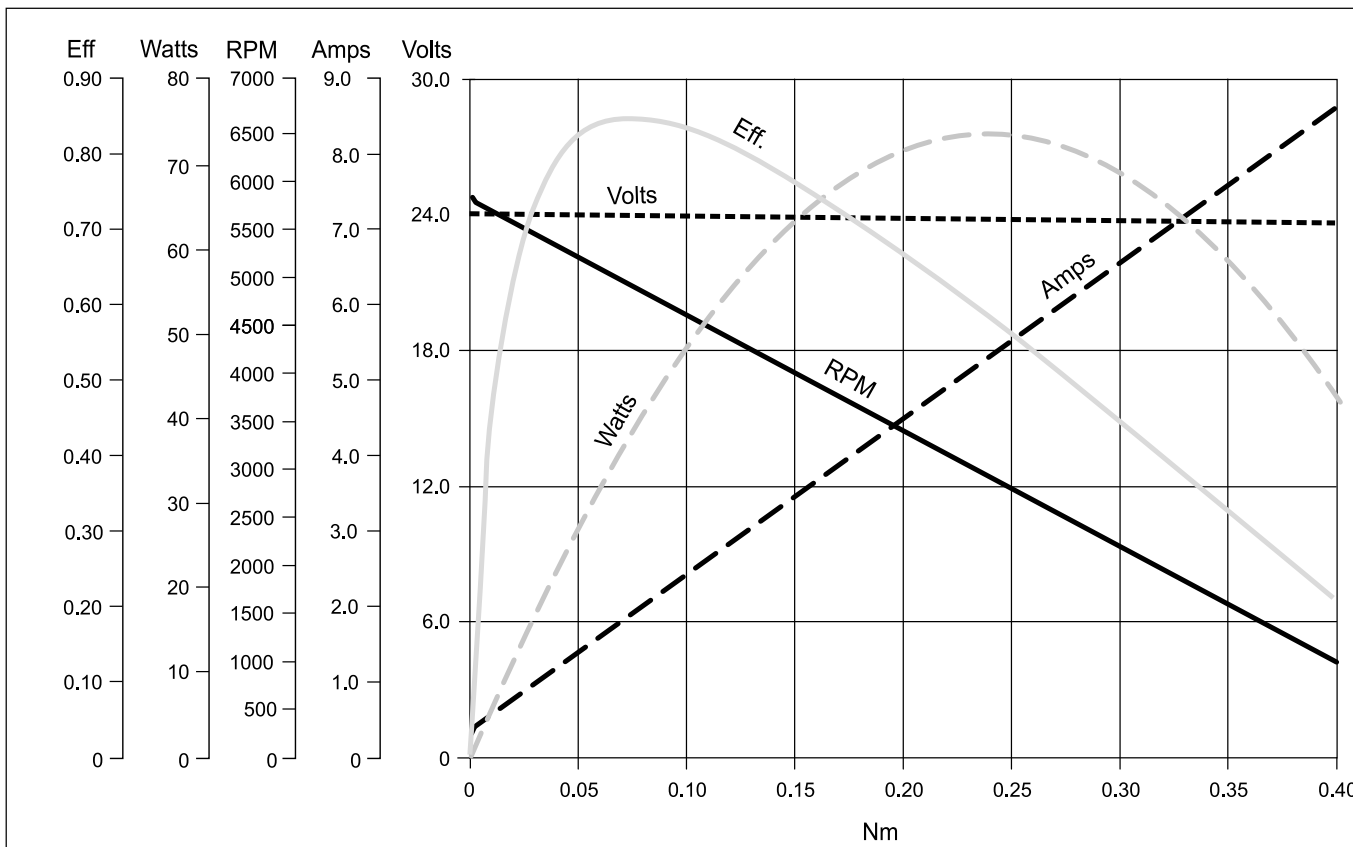

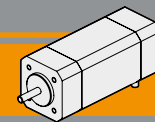

BL012.240 - BL012.240-IE

Dimensioni

Dimensions

BL012.240

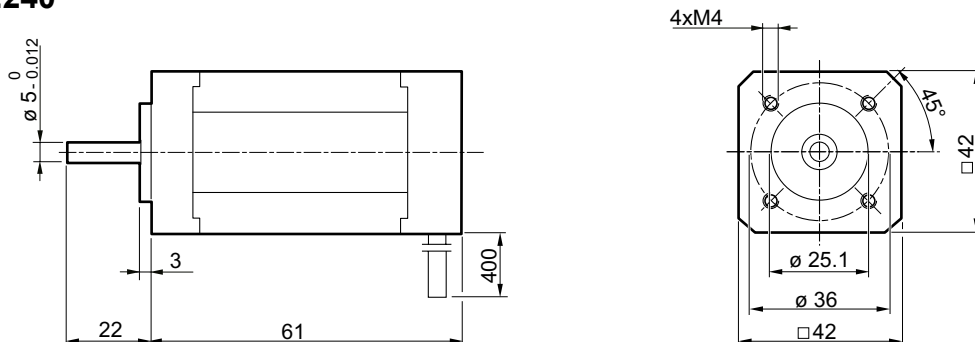

BL012.240-IE



Diagramma dei collegamenti

Connection diagram

BL012.240	
Cavi di potenza Power leads	Descrizione Description
Giallo / Yellow	Fase U / U motor Phase
Rosso / Red	Fase V / V motor Phase
Nero / Black	Fase W / W motor Phase

Cavi di segnale Signal leads	Descrizione Description
Blue	HALL fase U U phase HALL
Verde Green	HALL fase V V phase HALL
Bianco White	HALL fase W W phase HALL
Rosso (piccolo) Red (small)	Alimentazione HALL + 5Vcc Supply voltage for Hall sensors, + 5 Vdc
Nero (piccolo) Black (small)	Comune per i segnali di HALL Ground for HALL sensors

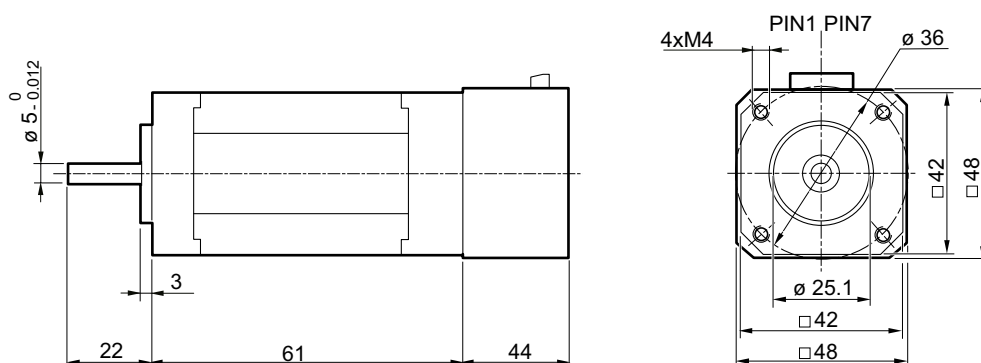
BL012.240-IE						
+5v	F/R	SV	PG	GND	-VP	+VP
1	2	3	4	5	6	7

7 +VP	Tensione positiva +24Vcc Power input +24VDC
6 -VP	Tensione negativa di alimentazione Power ground
5 GND	Riferimento comune per i segnali Common ground of system
4 PG	Impulsi per giro (24) Speed pulse output (TTL), 24 pulse/rev
3 SV	Potenziometro Speed voltage 0-5 VDC
2 F/R	Senso di marcia Rotating direction. Hi=CW
1 +5V	Tensione 5 Vcc in uscita +5V voltage output

Nota: Si raccomanda di seguire fedelmente gli schemi di collegamento qui riportati, pericolo di danneggiamento del motore o dell'elettronica.

Note: Pls, follow strictly the above connection diagrams, danger for the motor and the electric control

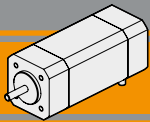

BL018.240 - BL018.240-IE

Specifiche costruttive

General features

Tipologia di avvolgimento <i>Winding type</i>	delta
Angolo sensori Hall <i>HALL effect angle</i>	120 gradi elettrici <i>120 degree electrical angle</i>
Gioco radiale <i>Radial play</i>	0.02 mm @ 450g
Gioco assiale <i>End play</i>	0.08 mm @ 450g
Scantatura albero <i>Shaft run out</i>	0.025 mm

Max forza radiale <i>Max radial force</i>	28N @ 20 mm dalla flangia <i>28N @ 20 mm from flange</i>
Max forza assiale <i>Max axial force</i>	10N
Classe di isolamento termico <i>Insulation class</i>	Classe B <i>Class B</i>
Isolamento dielettrico <i>Dielectric strength</i>	500Vcc x 1 minuto <i>500 Vdc 1 minute</i>
Resistenza isolamento <i>Insulation resistance</i>	100MΩ minimo, 500Vcc <i>100MΩ min, 500 Vdc</i>

Modello <i>Model</i>	Poli <i>Poles</i>	Fasi <i>Phases</i>	Tensione nominale	Velocità nominale	Coppia nominale	Potenza nominale	Coppia di picco	Corrente nominale	Corrente di picco	Resistenza fase-fase	Induttanza fase-fase	Costante di coppia	Costante FCEM	Inerzia rotore	Peso	IP
			<i>Rated voltage</i>	<i>Rated speed</i>	<i>Rated torque</i>	<i>Rated power</i>	<i>Peak torque</i>	<i>Rated current</i>	<i>Peak current</i>	<i>Line to line resistance</i>	<i>Line to line inductance</i>	<i>Torque constant</i>	<i>Back EMF</i>	<i>Rotor inertia</i>	<i>Weight</i>	
			[V]	[min ⁻¹]	[Nm]	[W]	[Nm]	[A]	[A]	[Ω]	[mH]	[Nm/A]	[V/kRPM]	[gcm ²]	[kg]	
BL018.240	8	3	24	4000	0.185	78	0.56	5	15.5	0.55	0.8	0.036	3.76	72	0.65	30
BL018.240-IE	8	3	24	4000	0.185	78	0.38	5	10.3	0.46	0.7	0.038	3.97	72	0.76	30

Azionamenti
Drives



Prestazioni

Performances

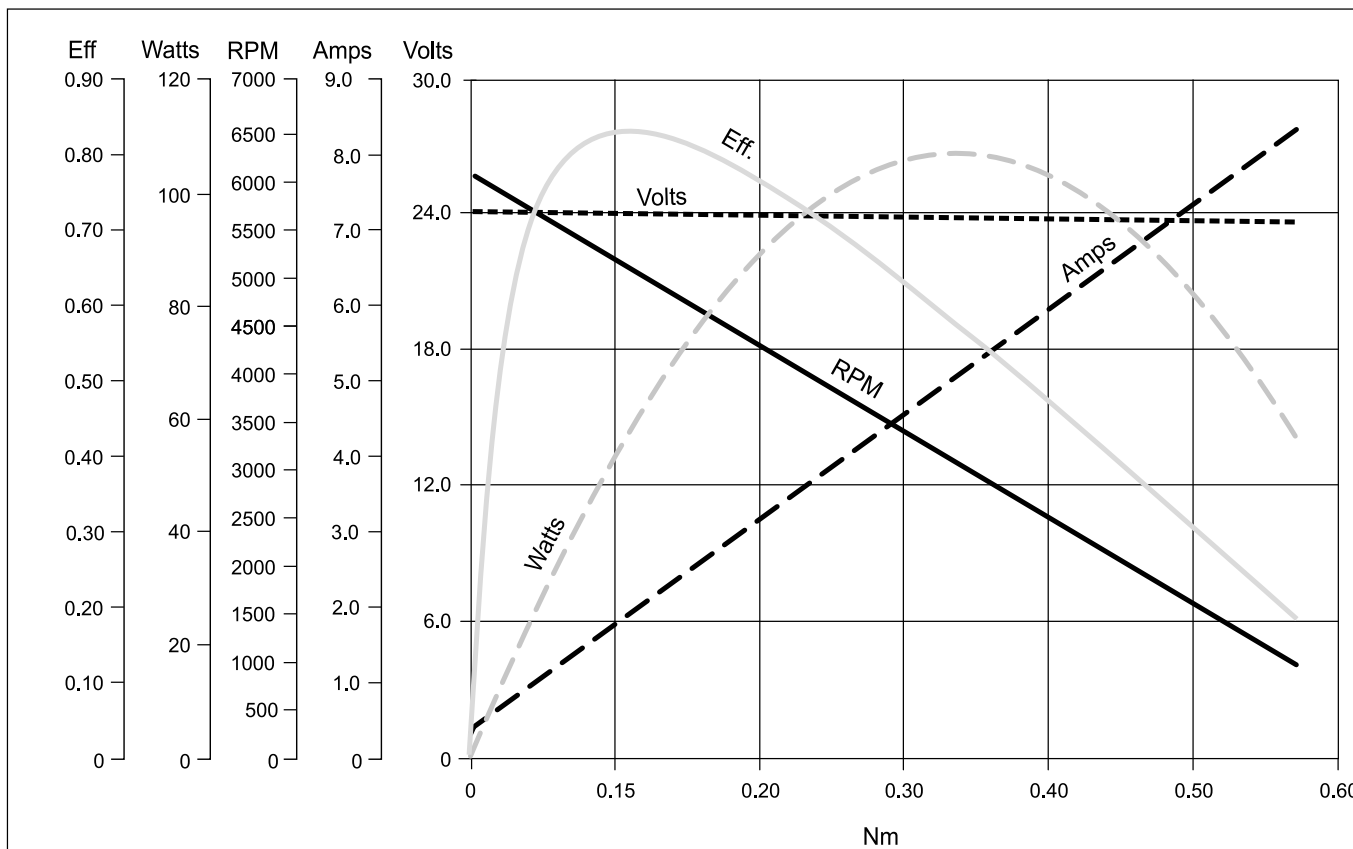

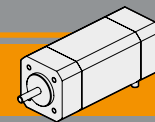

BL018.240 - BL018.240-IE

Dimensioni

Dimensions

BL018.240

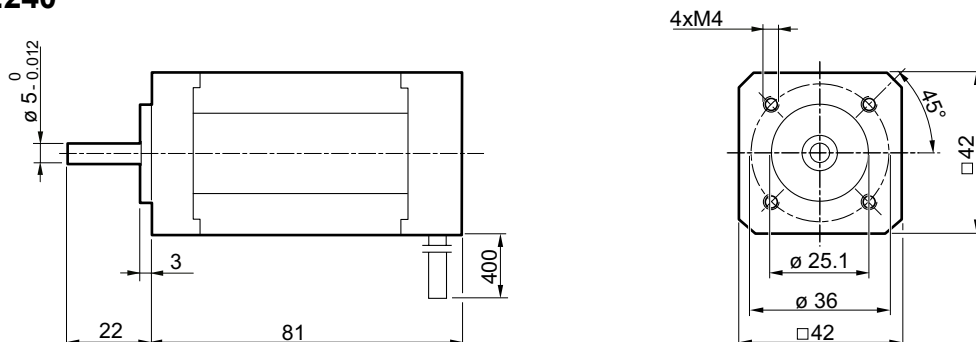

BL018.240-IE



Diagramma dei collegamenti

Connection diagram

BL018.240	
Cavi di potenza Power leads	Descrizione Description
Giallo / Yellow	Fase U / U motor Phase
Rosso / Red	Fase V / V motor Phase
Nero / Black	Fase W / W motor Phase

Cavi di segnale Signal leads	Descrizione Description
Blue	HALL fase U U phase HALL
Verde Green	HALL fase V V phase HALL
Bianco White	HALL fase W W phase HALL
Rosso (piccolo) Red (small)	Alimentazione HALL + 5Vcc Supply voltage for Hall sensors, + 5 Vdc
Nero (piccolo) Black (small)	Comune per i segnali di HALL Ground for HALL sensors

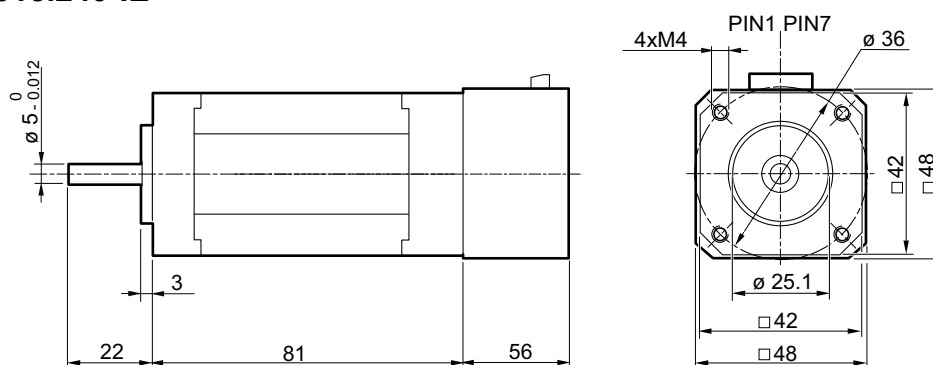
BL018.240-IE						
+5v	F/R	SV	PG	GND	-VP	+VP
1	2	3	4	5	6	7

7 +VP	Tensione positiva +24Vcc Power input +24VDC
6 -VP	Tensione negativa di alimentazione Power ground
5 GND	Riferimento comune per i segnali Common ground of system
4 PG	Impulsi per giro (24) Speed pulse output (TTL), 24 pulse/rev
3 SV	Potenziometro Speed voltage 0-5 VDC
2 F/R	Senso di marcia Rotating direction. Hi=CW
1 +5V	Tensione 5 Vcc in uscita +5V voltage output

Nota: Si raccomanda di seguire fedelmente gli schemi di collegamento qui riportati, pericolo di danneggiamento del motore o dell'elettronica.

Note: Pls, follow strictly the above connection diagrams, danger for the motor and the electric control

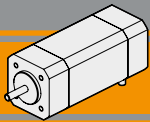

BL025.24E

Specifiche costruttive

General features

Tipologia di avvolgimento <i>Winding type</i>	delta
Angolo sensori Hall <i>HALL effect angle</i>	120 gradi elettrici <i>120 degree electrical angle</i>
Gioco radiale <i>Radial play</i>	0.02 mm @ 450g
Gioco assiale <i>End play</i>	0.08 mm @ 450g
Scenatura albero <i>Shaft run out</i>	0.025 mm

Max forza radiale <i>Max radial force</i>	28N @ 20 mm dalla flangia <i>28N @ 20 mm from flange</i>
Max forza assiale <i>Max axial force</i>	10N
Classe di isolamento termico <i>Insulation class</i>	Classe B <i>Class B</i>
Isolamento dielettrico <i>Dielectric strength</i>	500Vcc x 1 minuto <i>500 Vdc 1 minute</i>
Resistenza isolamento <i>Insulation resistance</i>	100MΩ minimo, 500Vcc <i>100MΩ min, 500 Vdc</i>

Modello <i>Model</i>	Poli <i>Poles</i>	Fasi <i>Phases</i>	Tensione nominale	Velocità nominale	Coppia nominale	Potenza nominale	Coppia di picco	Corrente nominale	Corrente di picco	Resistenza fase-fase	Induttanza fase-fase	Costante di coppia	Costante FCEM	Inerzia rotore	Peso	IP
			<i>Rated voltage</i>	<i>Rated speed</i>	<i>Rated torque</i>	<i>Rated power</i>	<i>Peak torque</i>	<i>Rated current</i>	<i>Peak current</i>	<i>Line to line resistance</i>	<i>Line to line inductance</i>	<i>Torque constant</i>	<i>Back EMF</i>	<i>Rotor inertia</i>	<i>Weight</i>	
			[V]	[min ⁻¹]	[Nm]	[W]	[Nm]	[A]	[A]	[Ω]	[mH]	[Nm/A]	[V/kRPM]	[gcm ²]	[kg]	
BL025.24E	8	3	24	4000	0.25	105	0.75	6.6	21	0.3	0.5	0.0376	3.9	96	0.8	30

Azionamenti
Drives



Prestazioni

Performances

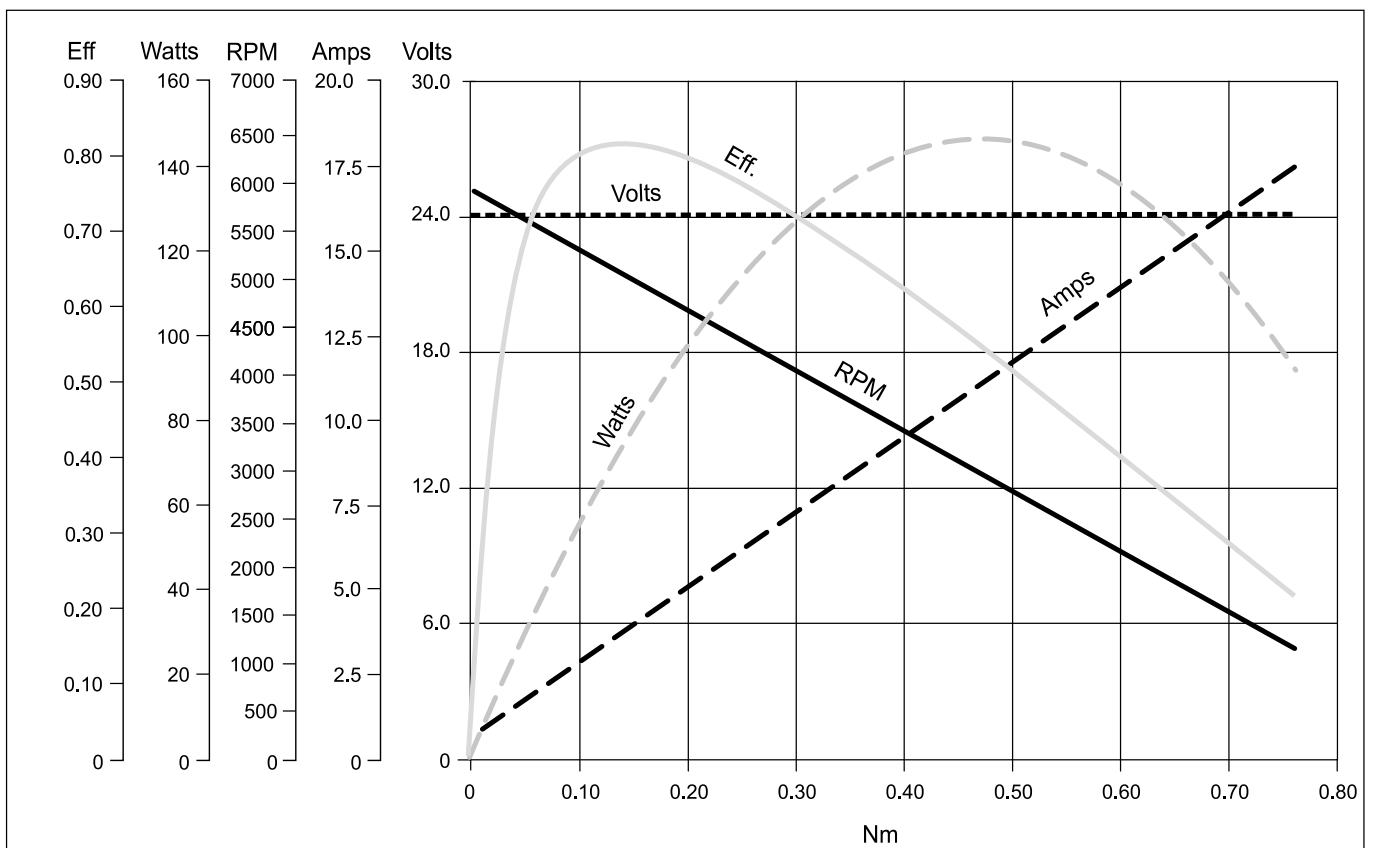

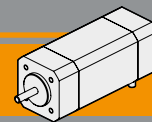

BL025.24E

Dimensioni

Dimensions

BL025.24E

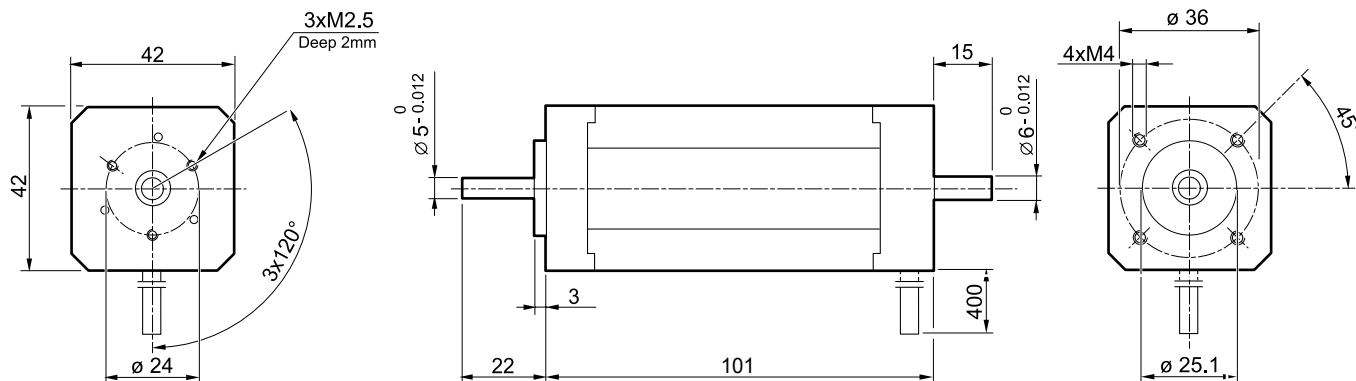

Per montaggio encoder serve flangia AS 4M.305
Encoder assembling needs flange AS 4M.305



Diagramma dei collegamenti

Connection diagram

Cavi di potenza Power leads	Descrizione Description
Giallo / Yellow	Fase U / U motor Phase
Rosso / Red	Fase V / V motor Phase
Nero / Black	Fase W / W motor Phase

Cavi di segnale Signal leads	Descrizione Description
Blue	HALL fase U U phase HALL
Verde Green	HALL fase V V phase HALL
Bianco White	HALL fase W W phase HALL
Rosso (piccolo) Red (small)	Alimentazione HALL + 5Vcc Supply voltage for Hall sensors, + 5 Vdc
Nero (piccolo) Black (small)	Comune per i segnali di HALL Ground for HALL sensors

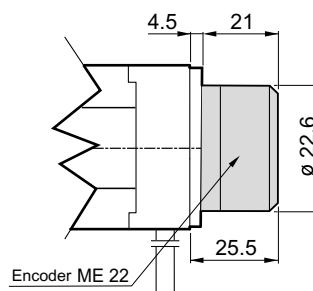
Nota: Si raccomanda di seguire fedelmente gli schemi di collegamento qui riportati, pericolo di danneggiamento del motore o dell'elettronica.

Note: Pls, follow strictly the above connection diagrams, danger for the motor and the electric control

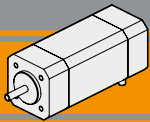

BL032.240 - BL032.240-IE

Specifiche costruttive

General features

Tipologia di avvolgimento <i>Winding type</i>	delta
Angolo sensori Hall <i>HALL effect angle</i>	120 gradi elettrici <i>120 degree electrical angle</i>
Gioco radiale <i>Radial play</i>	0.025 mm @ 460 g
Gioco assiale <i>End play</i>	0.025 mm @ 4000 g
Scentratura albero <i>Shaft run out</i>	0.025 mm

Max forza radiale <i>Max radial force</i>	75N @ 20 mm dalla flangia <i>75N @ 20 mm from flange</i>
Max forza assiale <i>Max axial force</i>	15N
Classe di isolamento termico <i>Insulation class</i>	Classe B <i>Class B</i>
Isolamento dielettrico <i>Dielectric strength</i>	500Vcc x 1 minuto <i>500 Vdc 1 minute</i>
Resistenza isolamento <i>Insulation resistance</i>	100MΩ minimo, 500Vcc <i>100MΩ min, 500 Vdc</i>

Modello <i>Model</i>	Poli <i>Poles</i>	Fasi <i>Phases</i>	Tensione nominale	Velocità nominale	Coppia nominale	Potenza nominale	Coppia di picco	Corrente nominale	Corrente di picco	Resistenza fase-fase	Induttanza fase-fase	Costante di coppia	Costante FCEM	Inerzia rotore	Peso	IP
			<i>Rated voltage</i>	<i>Rated speed</i>	<i>Rated torque</i>	<i>Rated power</i>	<i>Peak torque</i>	<i>Rated current</i>	<i>Peak current</i>	<i>Line to line resistance</i>	<i>Line to line inductance</i>	<i>Torque constant</i>	<i>Back EMF</i>	<i>Rotor inertia</i>	<i>Weight</i>	
			[V]	[min ⁻¹]	[Nm]	[W]	[Nm]	[A]	[A]	[Ω]	[mH]	[Nm/A]	[V/kRPM]	[gcm ²]	[kg]	
BL032.240	4	3	36	4000	0.32	135	1.0	5	16.5	0.45	1.4	0.063	6.6	173	1.0	20
BL032.240-IE	4	3	36	4000	0.32	135	0.64	5	11.0	0.45	1.65	0.061	6.3	173	1.18	30
BL032.240	4	3	24	3000	0.32	100	1.0	5	16.5	0.45	1.4	0.063	6.6	173	1.0	20
BL032.240-IE	4	3	24	3000	0.32	100	0.64	5	11.0	0.45	1.65	0.061	6.3	173	1.18	30



Prestazioni

Performances

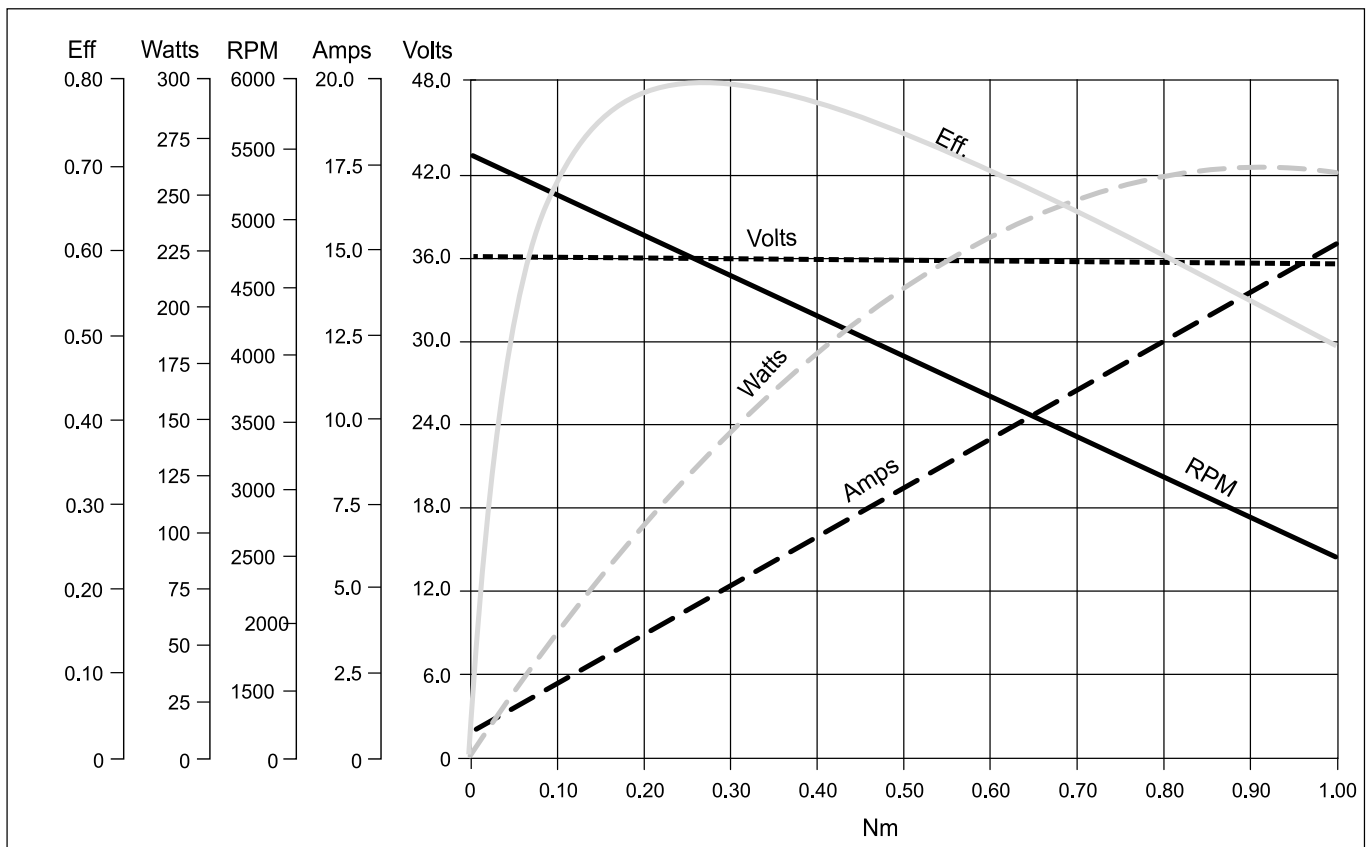

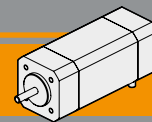

BL032.240 - BL032.240-IE

Dimensioni

Dimensions

BL032.240

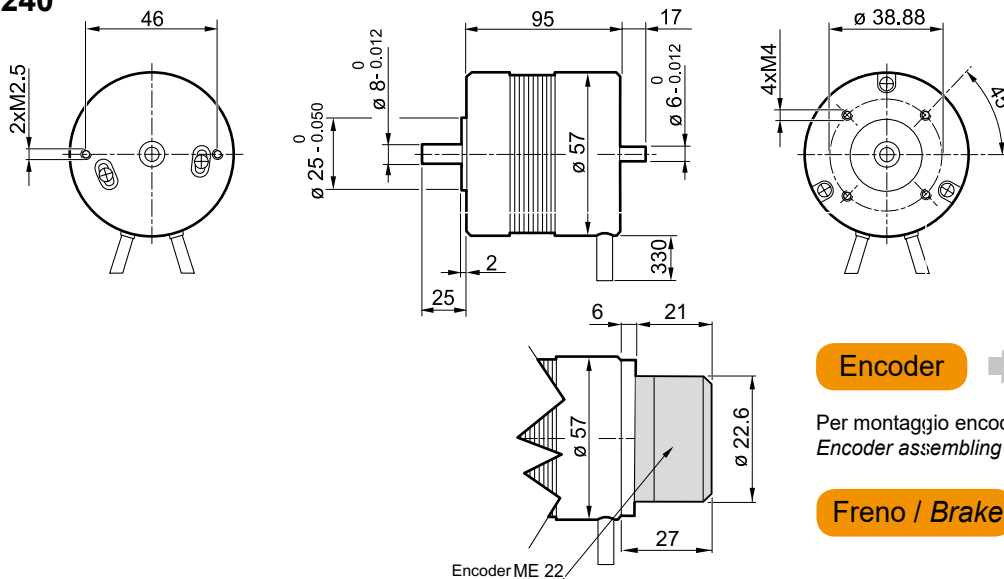

Encoder

I2

Per montaggio encoder serve flangia AS 4M.294
Encoder assembling needs flange AS 4M.294

Freno / Brake

E18

BL032.240-IE



Diagramma dei collegamenti

Connection diagram

BL032.240	
Cavi di potenza Power leads	Descrizione Description
Giallo / Yellow	Fase U / U motor Phase
Rosso / Red	Fase V / V motor Phase
Nero / Black	Fase W / W motor Phase

Cavi di segnale Signal leads	Descrizione Description
Blue	HALL fase U U phase HALL
Verde Green	HALL fase V V phase HALL
Bianco White	HALL fase W W phase HALL
Rosso (piccolo) Red (small)	Alimentazione HALL + 5Vcc Supply voltage for Hall sensors, + 5 Vdc
Nero (piccolo) Black (small)	Comune per i segnali di HALL Ground for HALL sensors

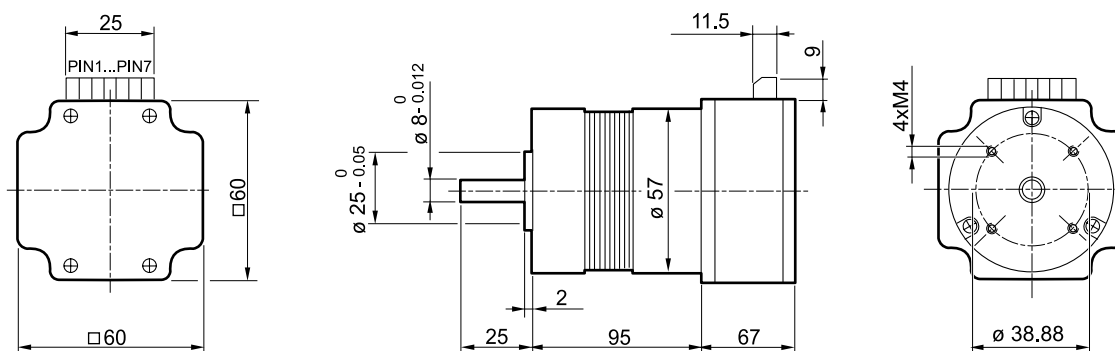
BL032.240-IE						
+5v	F/R	SV	PG	GND	-VP	+VP
1	2	3	4	5	6	7

7 +VP	Tensione positiva +24Vcc Power input +24VDC
6 -VP	Tensione negativa di alimentazione Power ground
5 GND	Riferimento comune per i segnali Common ground of system
4 PG	Impulsi per giro (12) Speed pulse output (TTL), 12 pulse/rev
3 SV	Potenziometro Speed voltage 0-5 VDC
2 F/R	Senso di marcia Rotating direction. Hi=CW
1 +5V	Tensione 5 Vcc in uscita +5V voltage output

Nota: Si raccomanda di seguire fedelmente gli schemi di collegamento qui riportati, pericolo di danneggiamento del motore o dell'elettronica.

Note: Pls, follow strictly the above connection diagrams, danger for the motor and the electric control

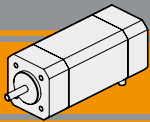

BL043.240 - BL043.240-IE

Specifiche costruttive

General features

Tipologia di avvolgimento <i>Winding type</i>	delta
Angolo sensori Hall <i>HALL effect angle</i>	120 gradi elettrici <i>120 degree electrical angle</i>
Gioco radiale <i>Radial play</i>	0.025 mm @ 460 g
Gioco assiale <i>End play</i>	0.025 mm @ 4000 g
Scentratura albero <i>Shaft run out</i>	0.025 mm

Max forza radiale <i>Max radial force</i>	75N @ 20 mm dalla flangia <i>75N @ 20 mm from flange</i>
Max forza assiale <i>Max axial force</i>	15N
Classe di isolamento termico <i>Insulation class</i>	Classe B <i>Class B</i>
Isolamento dielettrico <i>Dielectric strength</i>	500Vcc x 1 minuto <i>500 Vdc 1 minute</i>
Resistenza isolamento <i>Insulation resistance</i>	100MΩ minimo, 500Vcc <i>100MΩ min, 500 Vdc</i>

Modello <i>Model</i>	Poli <i>Poles</i>	Fasi <i>Phases</i>	Tensione nominale	Velocità nominale	Coppia nominale	Potenza nominale	Coppia di picco	Corrente nominale	Corrente di picco	Resistenza fase-fase	Induttanza fase-fase	Costante di coppia	Costante FCEM	Inerzia rotore	Peso	IP
			<i>Rated voltage</i>	<i>Rated speed</i>	<i>Rated torque</i>	<i>Rated power</i>	<i>Peak torque</i>	<i>Rated current</i>	<i>Peak current</i>	<i>Line to line resistance</i>	<i>Line to line inductance</i>	<i>Torque constant</i>	<i>Back EMF</i>	<i>Rotor inertia</i>	<i>Weight</i>	
			[V]	[min ⁻¹]	[Nm]	[W]	[Nm]	[A]	[A]	[Ω]	[mH]	[Nm/A]	[V/kRPM]	[gcm ²]	[kg]	
BL043.240	4	3	36	4000	0.43	180	1.27	6.8	20.5	0.35	1.0	0.063	6.6	230	1.25	20
BL043.240-IE	4	3	36	4000	0.43	180	0.86	6.8	13.6	0.38	1.0	0.063	6.6	230	1.44	30
BL043.240	4	3	24	3000	0.43	130	1.27	6.8	20.5	0.35	1.0	0.063	6.6	230	1.25	20
BL043.240-IE	4	3	24	3000	0.43	130	0.86	6.8	13.6	0.38	1.0	0.063	6.6	230	1.44	30



Prestazioni

Performances

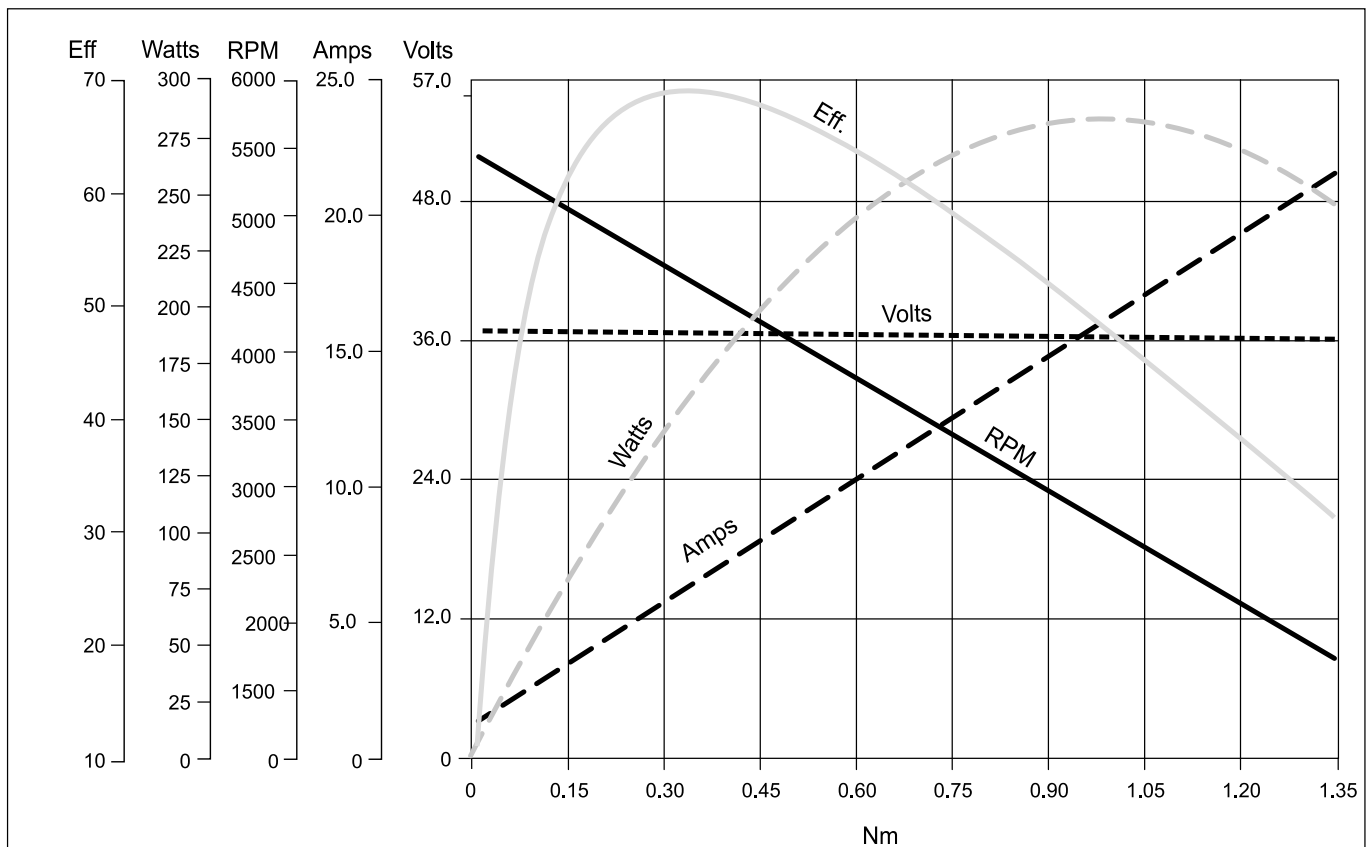

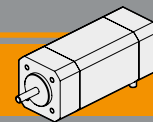

BL043.240 - BL043.240-IE

Dimensioni

Dimensions

BL043.240

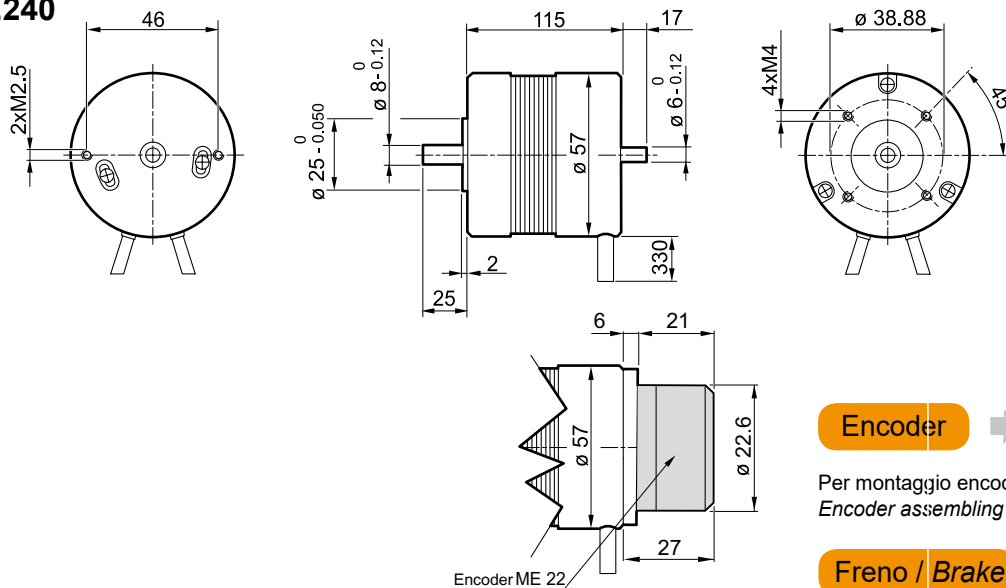

BL043.240-IE



Diagramma dei collegamenti

Connection diagram

BL043.240	
Cavi di potenza Power leads	Descrizione Description
Giallo / Yellow	Fase U / U motor Phase
Rosso / Red	Fase V / V motor Phase
Nero / Black	Fase W / W motor Phase

Cavi di segnale Signal leads	Descrizione Description
Blue	HALL fase U U phase HALL
Verde Green	HALL fase V V phase HALL
Bianco White	HALL fase W W phase HALL
Rosso (piccolo) Red (small)	Alimentazione HALL + 5Vcc Supply voltage for Hall sensors, + 5 Vdc
Nero (piccolo) Black (small)	Comune per i segnali di HALL Ground for HALL sensors

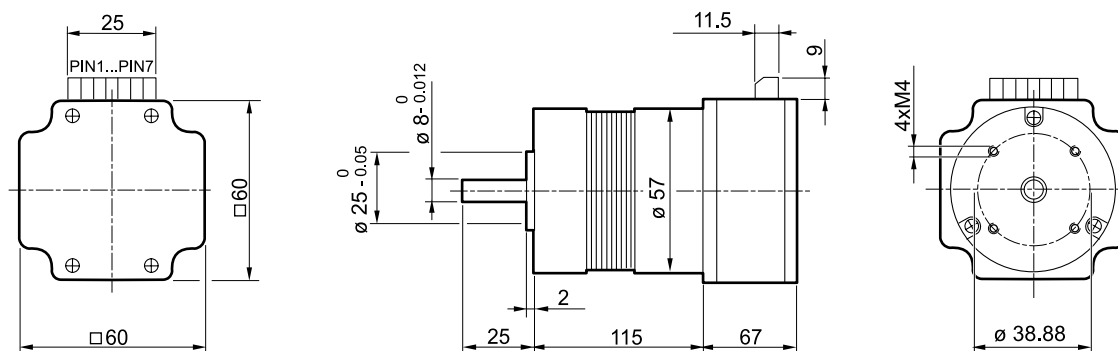
BL043.240-IE						
+5v	F/R	SV	PG	GND	-VP	+VP
1	2	3	4	5	6	7

7 +VP	Tensione positiva +24Vcc Power input +24VDC
6 -VP	Tensione negativa di alimentazione Power ground
5 GND	Riferimento comune per i segnali Common ground of system
4 PG	Impulsi per giro (12) Speed pulse output (TTL), 12 pulse/rev
3 SV	Potenzimetro Speed voltage 0-5 VDC
2 F/R	Senso di marcia Rotating direction. Hi=CW
1 +5V	Tensione 5 Vcc in uscita +5V voltage output

Nota: Si raccomanda di seguire fedelmente gli schemi di collegamento qui riportati, pericolo di danneggiamento del motore o dell'elettronica.

Note: Pls, follow strictly the above connection diagrams, danger for the motor and the electric control

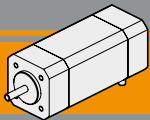

Motori brushless CC Brushless DC motors

BL070.48E

Specifiche costruttive

General features

Tipologia di avvolgimento <i>Winding type</i>	Stella <i>Star</i>	Max forza radiale <i>Max radial force</i>	220N @ 20 mm dalla flangia <i>220N @ 20 mm from flange</i>
Angolo sensori Hall <i>HALL effect angle</i>	120 gradi elettrici <i>120 degree electrical angle</i>	Max forza assiale <i>Max axial force</i>	60N
Gioco radiale <i>Radial play</i>	0.02 mm @ 450g	Classe di isolamento termico <i>Insulation class</i>	Classe B <i>Class B</i>
Gioco assiale <i>End play</i>	0.08 mm @ 450g	Isolamento dielettrico <i>Dielectric strength</i>	500Vcc x 1 minuto <i>500 Vdc 1 minute</i>
Scentratura albero <i>Shaft run out</i>	0.05 mm	Resistenza isolamento <i>Insulation resistance</i>	100MΩ minimo, 500Vcc <i>100MΩ min, 500 Vdc</i>

Modello <i>Model</i>	Poli <i>Poles</i>	Fasi <i>Phases</i>	Tensione nominale	Velocità nominale	Coppia nominale	Potenza nominale	Coppia di picco	Corrente nominale	Corrente di picco	Resistenza fase-fase	Induttanza fase-fase	Costante di coppia	Costante FCEM	Inerzia rotore	Peso	IP
			<i>Rated voltage</i>	<i>Rated speed</i>	<i>Rated torque</i>	<i>Rated power</i>	<i>Peak torque</i>	<i>Rated current</i>	<i>Peak current</i>	<i>Line to line resistance</i>	<i>Line to line inductance</i>	<i>Torque constant</i>	<i>Back EMF</i>	<i>Rotor inertia</i>	<i>Weight</i>	
			[V]	[min ⁻¹]	[Nm]	[W]	[Nm]	[A]	[A]	[Ω]	[mH]	[Nm/A]	[V/kRPM]	[gcm ²]	[kg]	
BL070.48E	8	3	48	3000	0.7	220	2.1	6.5	20	0.34	1.0	0.107	9	0.8	2.1	20

Azionamenti
Drives



Prestazioni

Performances

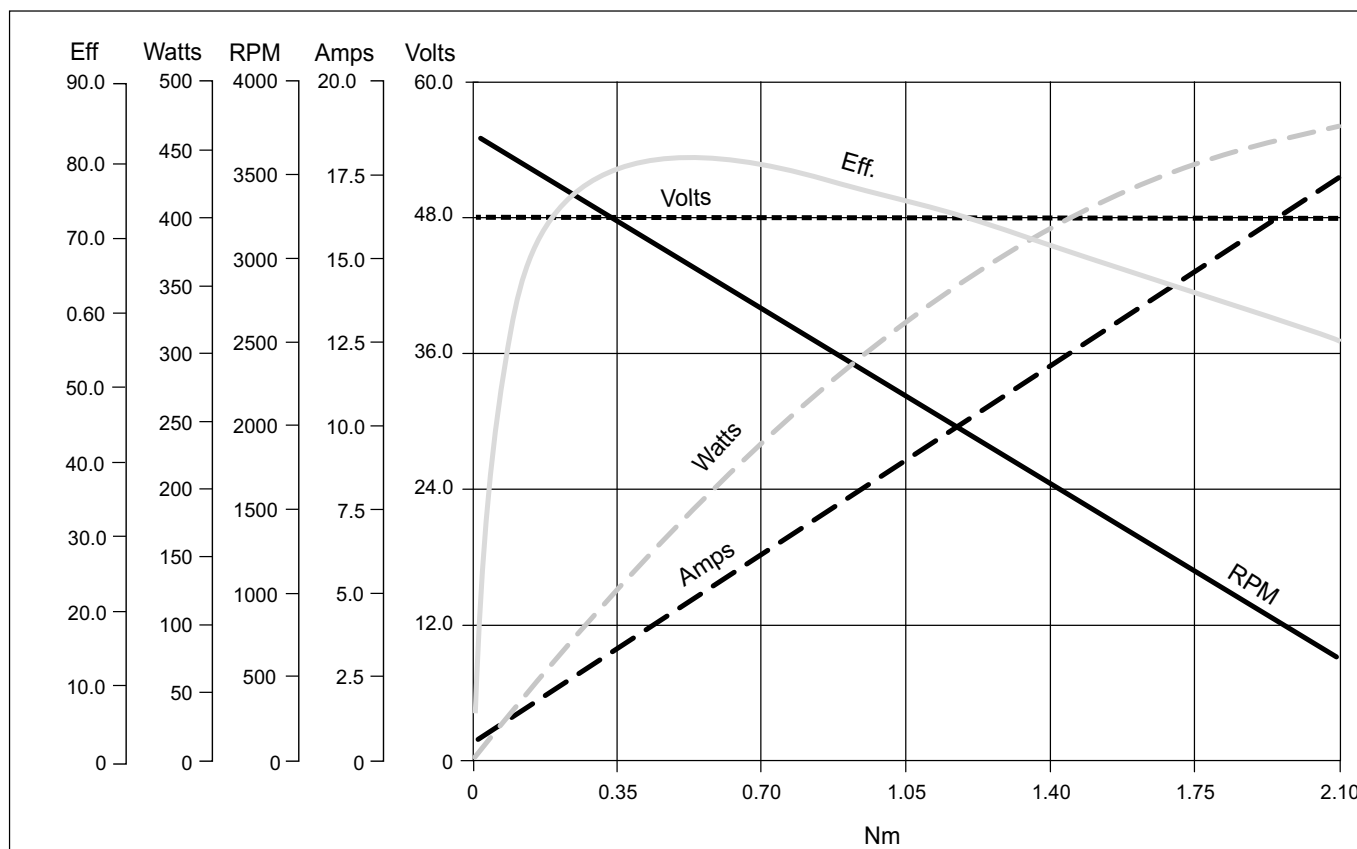

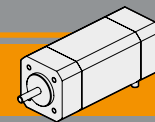

BL070.48E

Dimensioni

Dimensions

BL070.48E

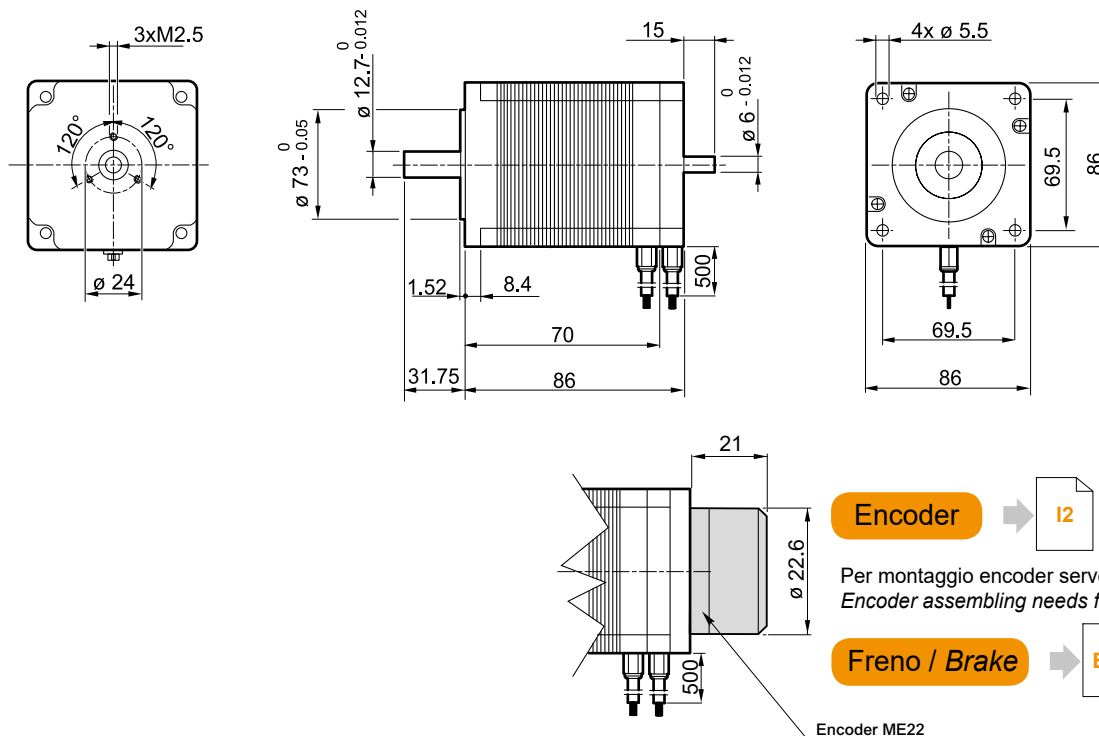

Encoder → I2
Per montaggio encoder serve flangia AS 4M.305
Encoder assembling needs flange AS 4M.305

Freno / Brake → E18

Encoder ME22

Diagramma dei collegamenti

Connection diagram

Cavi di potenza Power leads	Descrizione Description
Blu / Blue	Fase U / U motor Phase
Marrone / Brown	Fase V / V motor Phase
Nero / Black	Fase W / W motor Phase

Cavi di segnale Signal leads	Descrizione Description
Blu / Blue	HALL fase U U phase HALL
Verde / Green	HALL fase V V phase HALL
Bianco / White	HALL fase W W phase HALL
Rosso (piccolo) / Red (small)	Alimentazione HALL + 5Vcc Supply voltage for Hall sensors, + 5 Vdc
Nero (piccolo) / Black (small)	Comune per i segnali di HALL Ground for HALL sensors

Nota: Si raccomanda di seguire fedelmente gli schemi di collegamento qui riportati, pericolo di danneggiamento del motore o dell'elettronica.

Note: Pls, follow strictly the above connection diagrams, danger for the motor and the electric control

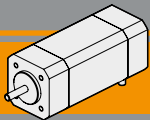

Freno

Brake

Freno / Brake

BL032...BR
BL043...BR

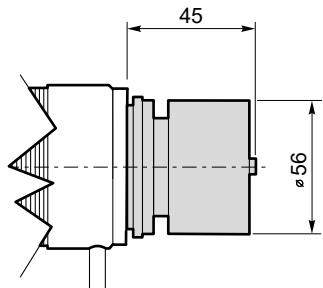

Freno con leva di sblocco/ Brake with hand release

BL032...BRL
BL043...BRL

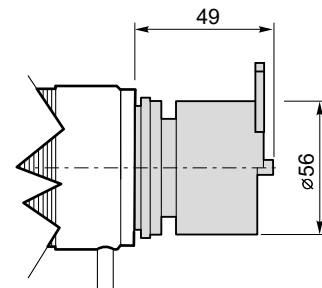
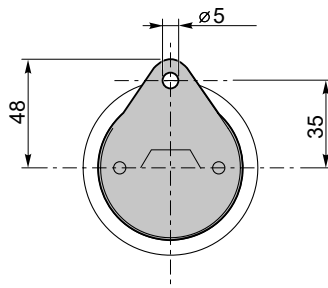

	P_n [W]	V [V]	M_n [Nm]	n₁ [min ⁻¹]
Caratteristiche del freno / Break features	14	12	2	3000
		24		

BL070...BR

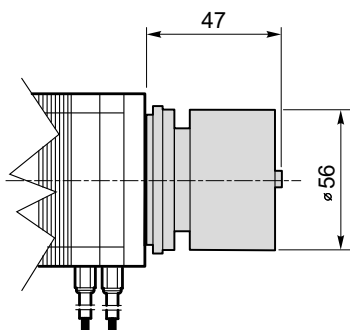

BL070...BRL

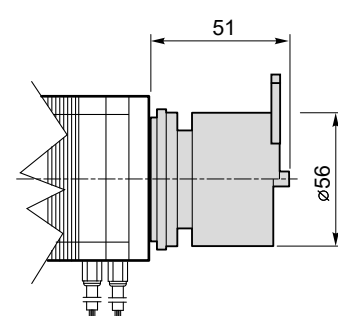
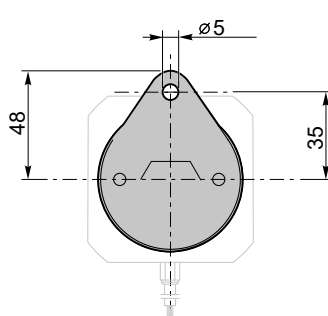

	P_n [W]	V [V]	M_n [Nm]	n₁ [min ⁻¹]
Caratteristiche del freno / Break features	14	12	2	3000
		24		

Micro motoriduttori brushless CC epicicloidali Micro brushless DC planetary gearmotors

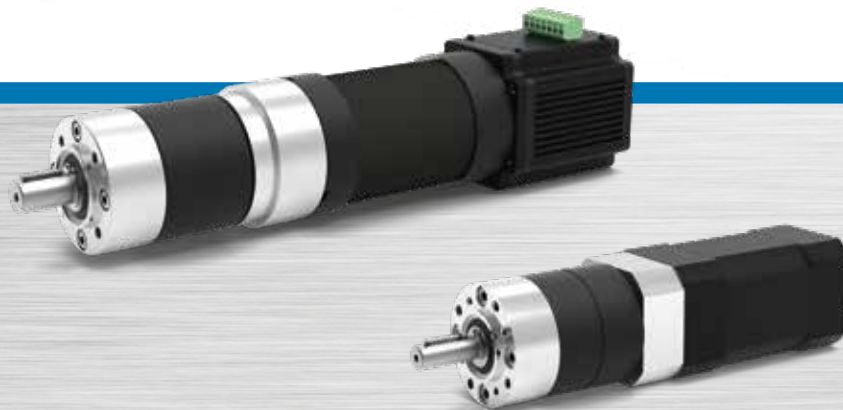

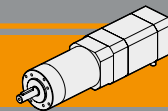

Indice	Index	Pag. Page
Caratteristiche tecniche	<i>Technical features</i>	F2
Designazione	<i>Classification</i>	F2
Simbologia	<i>Symbols</i>	F2
Lubrificazione	<i>Lubrication</i>	F2
Carichi radiali	<i>Radial loads</i>	F3
Rapporti	<i>Ratios</i>	F3
PK-P32 con motore brushless	<i>PK-P32 with brushless motor</i>	F4
PM32LN con motore brushless	<i>PM32LN with brushless motor</i>	F6
PK-P42 con motore brushless	<i>PK-P42 with brushless motor</i>	F8
P42 con motore brushless	<i>P42 with brushless motor</i>	F10
PK-P52 con motore brushless	<i>PK-P52 with brushless motor</i>	F12

Questa sezione annulla e sostituisce ogni precedente edizione o revisione. Qualora questa sezione non Vi sia giunta in distribuzione controllata, l'aggiornamento dei dati ivi contenuto non è assicurato. **In tal caso la versione più aggiornata è disponibile sul nostro sito internet www.intecno-srl.com**

*This section replaces any previous edition and revision. If you obtained this catalogue other than through controlled distribution channels, the most up to date content is not guaranteed. **In this case the latest version is available on our web site www.intecno-srl.com***

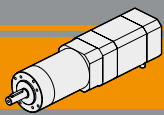

Micro motoriduttori brushless CC epicycloidali

Micro brushless DC planetary gearmotors

Caratteristiche tecniche

Technical features

Le caratteristiche principali dei motoriduttori epicycloidali brushless CC della serie PK-P-PM LN sono:

- Alimentazione in bassa tensione 24/36/48 Vdc
- Possibilità di montaggio encoder
- Coppie motori disponibili 37mNm a 0,7Nm
- Elettronica di comando integrata IE (opzionale)
- Lubrificazione permanente a grasso

Soluzione PK-BB:

- Mix plastica/metallo
- Doppio cuscinetto su albero di uscita

Soluzione P:

- Completamente in metallo
- Doppio cuscinetto su albero di uscita

Soluzione PM LN:

- Versione bassa rumorosità della versione P

The main features of brushless DC planetary gearmotors range PK-P-PM LN series are:

- Low voltage power supply 24/36/48 Vdc
- Suitable for encoder assembly
- Motor torque ratings available from 37mNm up to 0,7Nm
- Integrated speed controller IE (optional)
- Permanent grease long life lubrication

PK-BB solution:

- Plastic/metal mix
- Double ball bearing on output shaft

P solution:

- Completely made out of metal
- Double ball bearing on output shaft

PM LN solution:

- Low noise version of P solution

Designazione

Classification

RIDUTTORE / GEARBOX					MOTORE / MOTOR		
PK	42	2	46	BB	BL012.240	24V	IE
Tipo Type	Grandezza Size	Stadi riduttore Gearbox stages	Rapporto in Ratio in	Versione Version	Tipo Type	Tensione Voltage	Opzioni Options
PK	32 42	1 2 3 4	Vedere tabelle See tables	BB	BL005.240 BL012.240 BL018.240 BL025.24E BL032.240 BL043.240	24V 36V 48V	IE Encoder 
P	52 62			-			
PM	32			LN			

Simbologia

Symbols

Ns	n° stadi / No. stages	Pn	[W]	Potenza nominale / Nominal power
in	rapporto nominale / nominal ratio	V	[V]	Tensione / Voltage
ir	rapporto reale / real ratio	I	[A]	Assorbimento / Current
M _n	[Nm] coppia in uscita in funzionamento continuativo S1 output torque for continuous operation S1	IC		Classe di isolamento termico / Thermal insulation class
Rd	rendimento dinamico / efficiency	FF		Fattore di forma / Form factor
R ₂	[N] massimo carico radiale al centro dell'albero uscita max. radial load at output shaft centre	Mn	[Nm]	Coppia / Torque
A ₂	[N] massimo carico assiale / max. axial load	n ₁	[Rpm]	Giri / Speed
		IP		Grado di protezione / Enclosure protection
		Kg		Peso / Weight

Lubrificazione

Lubrication

I riduttori epicycloidali sono lubrificati in modo permanente, non richiedono quindi ulteriore manutenzione.

Questo gli consente di essere installati praticamente ovunque. Temperatura ambiente 0 ÷ 40 °C (in assenza di congelamento ed in assenza di condensa).

Per temperature diverse, contattare nostro UT.

Planetary gearboxes are life-time lubricated with grease, therefore they are maintenance free.

They can be installed in any location. Ambient temperature 0 ÷ 40 °C (in the absence of freezing and condensation).

For temperature outside this range please contact our technical dept.

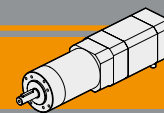

Carichi radiali

Radial loads

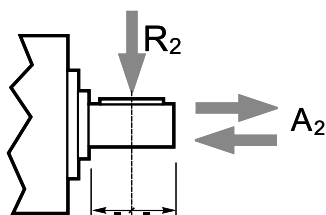

Ns	Carichi Radiali R ₂ [N] / Radial Load R ₂ [N]						
	PK32BB	P32	PM32LN	PK42SB	P42	PK52BB	P52
1	40	40	40	15	160	200	200
2	70	70	70	30	230	320	320
3	100	100	100	45	300	450	450
4	100	130	130	45	360	500	500

Ns	Carichi Assiali A ₂ [N] / Axial Load A ₂ [N]						
	PK32BB	P32	PM32LN	PK42SB	P42	PK52BB	P52
1	10	10	10	5	50	60	60
2	20	20	20	10	80	100	100
3	30	30	30	30	110	150	150
4	30	40	40	30	140	200	200

Rapporti

Ratios

PK BB / P 32 42 52		
Ns	in	ir
1	4	3.7
	4	4.28
	5	5.18
	7	6.75
2	14	13.73
	16	15.88
	18	18.36
	19	19.2
	22	22.2
	25	25.01
	27	26.85
	29	28.93
	35	34.97
	46	45.56
3	51	50.89
	59	58.85
	68	68.06
	71	71.16
	79	78.71
	93	92.7
	95	95.17
	100	99.5
	107	107.2
	115	115.07
	124	123.97
	130	129.62
	139	139.13
	150	149.9
	169	168.84
	181	181.24
195	195.26	
236	236.09	
308	307.54	
4	a richiesta	on request

BASSA RUMOROSITA' / LOW NOISE PM 32 LN (*)		
Ns	in	ir
1	4	3.7
	4	4.28
	5	5.18
	7	6.75
2	14	13.73
	16	15.88
	18	18.36
	19	19.2
	22	22.2
	25	25.01
	27	26.85
	29	28.93
	35	34.97
	46	45.56
3	51	50.89
	59	58.85
	68	68.06
	71	71.16
	79	78.71
	93	92.7
	95	95.17
	100	99.5
	107	107.2
	115	115.07
	124	123.97
	130	129.62
	139	139.13
	150	149.9
	169	168.84
	181	181.24
195	195.26	
236	236.09	
308	307.54	
4	369	368.76
	721	720.98

(*) PM42 LN / PM52 LN / PM62 LN: disponibili a richiesta / on request

Rapporti preferenziali
Preferred ratios

Disponibile a 4 stadi con rapporti fino a 2076
Available 4 stages with ratio up to 2076

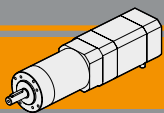

Micro motoriduttori brushless CC epicicloidali

Micro brushless DC planetary gearmotors

PK-P32 con motore brushless CC

PK-P32 with DC brushless motor

PK32BB								BL005.240				BL005.240-IE			
								Coppia nominale Rated torque 24V		Coppia massima Peak torque 24V		Coppia nominale Rated torque 24V		Coppia massima Peak torque 24V	
Ns	in	ir	M _n [Nm]	Rd	R ₂ [N]	A ₂ [N]	Kg	[Nm]	[rpm]	[Nm]	[rpm]	[Nm]	[rpm]	[Nm]	[rpm]
1	4	3.70	0.6	0.75	40	10	0.12	0.14	1000	0.28	1000	0.06	811	0.12	811
	7	6.75						0.25	548	0.5	548	0.11	444	0.22	444
2	14	13.73	1.5	0.7	70	20	0.14	0.48	269	0.96	269	0.21	218	0.42	218
	25	25.01						0.88	148	1.76	148	0.39	120	0.77	120
	46	45.56						1.59	81	3.18	81	0.70	66	1.40	66
3	68	68.06	3	0.65	100	30	0.15	2.21	54	4.42	54	0.97	44	1.94	44
	93	92.70						3.01	40	6.02	40	1.32	32	2.65	32
	169	168.84						5.49	22	10.98	22	2.42	18	4.83	18
	308	307.54						10	12	20	12	4.40	10	8.80	10

P32								BL005.240				BL005.240-IE			
								Coppia nominale Rated torque 24V		Coppia massima Peak torque 24V		Coppia nominale Rated torque 24V		Coppia massima Peak torque 24V	
Ns	in	ir	M _n [Nm]	Rd	R ₂ [N]	A ₂ [N]	Kg	[Nm]	[rpm]	[Nm]	[rpm]	[Nm]	[rpm]	[Nm]	[rpm]
1	4	3.70	0.75	0.8	40	10	0.16	0.15	1000	0.29	1000	0.06	811	0.13	811
	7	6.75						0.26	548	0.53	548	0.12	444	0.23	444
2	14	13.73	2.3	0.75	70	20	0.21	0.50	269	1.01	269	0.22	218	0.44	218
	25	25.01						0.92	148	1.85	148	0.41	120	0.81	120
	46	45.56						1.67	81	3.34	81	0.73	66	1.47	66
3	68	68.06	4.5	0.7	100	30	0.26	2.32	54	4.64	54	1.02	44	2.04	44
	93	92.70						3.16	40	6.32	40	1.39	32	2.78	32
	169	168.84						5.76	22	11.53	22	2.54	18	5.07	18
	308	307.54						10.50	12	21.00	12	4.62	10	9.24	10

Nota: le caselle in colore grigio indicano il superamento della coppia massima sopportata dal riduttore per il servizio in S1.
Per vedere tutti i rapporti di riduzione disponibili, vedere tabella a pag. E3

N.B.: boxes in grey indicate that maximum torque withstood by gear reducer for service in S1 is exceeded.
See the table on page E3 for all available ratios.

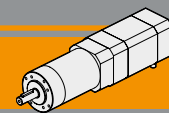

PK-P32 con motore brushless CC

PK-P32 with DC brushless motor

Tipo Type	Numero di poli Number of poles	Numero di fasi Number of phase	Tensione Rated voltage [V]	Numero di giri Rated speed [rpm]	Coppia nominale Rated torque [mNm]	Potenza nominale Rated power [W]
BL005.240	4	3	24	3700	50	16
BL005.240-IE	4	3	24	3000	22	7
Tipo Type	Coppia massima Peak torque [Nm]	Corrente nominale Rated current [A]	Resistenza Resistance [ohm]	Induttanza Inductance [mH]	Corrente massima Peak current [A]	Peso Weight [kg]
BL005.240	0.1	1.0	4.67	3.5	2.0	0.208
BL005.240-IE	0.044	0.55	4.67	3.5	1.1	0.220

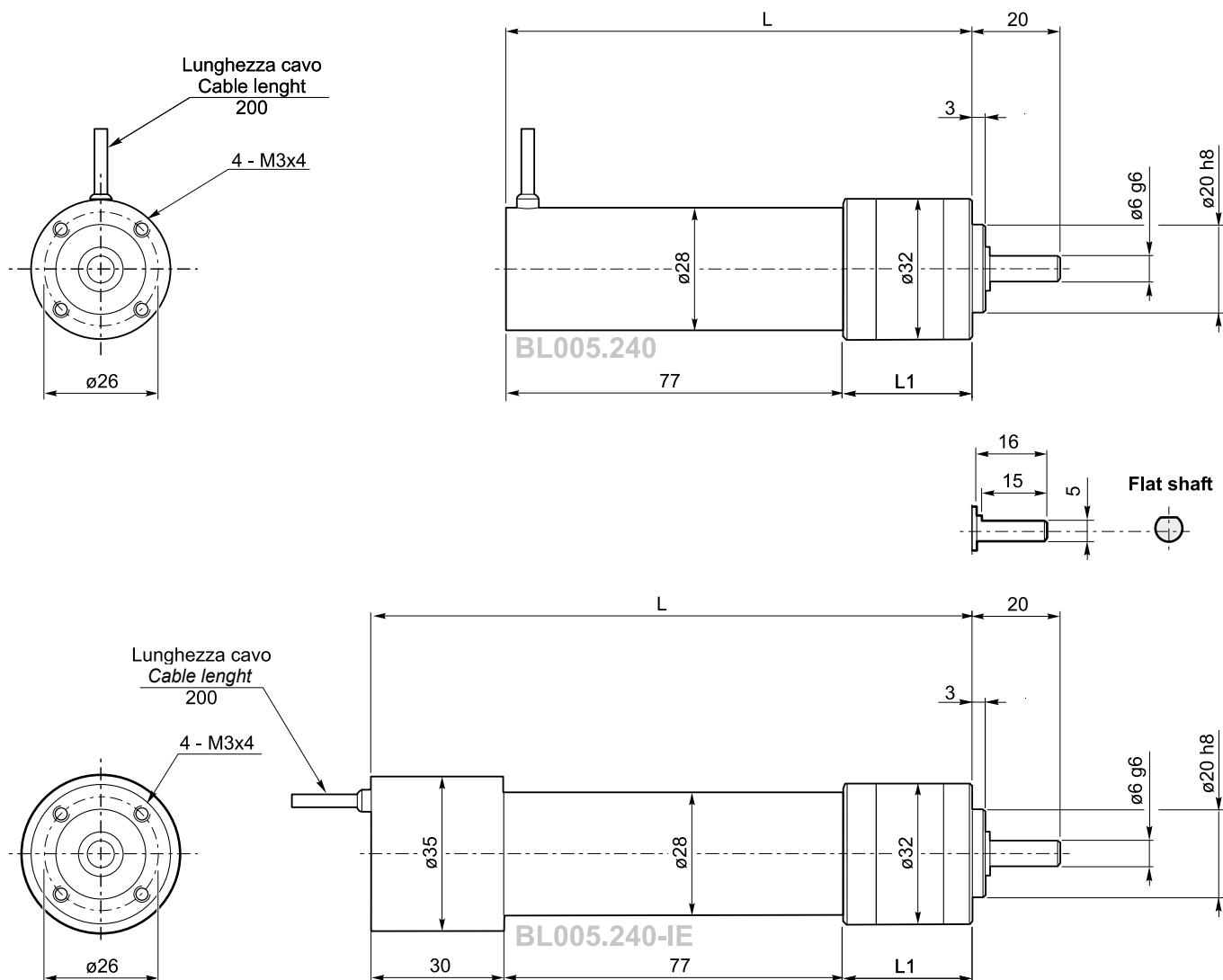

PK32BB P32			BL005.240	BL005.240-IE
	Ns	L1	L	L
	1	38.5	115.5	145.5
	2	48	125	158
	3	57.5	134.5	167.5

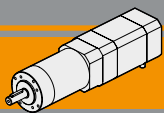

PK-P42 con motore brushless CC

PK-P42 with DC brushless motor

PK42BB								BL012.240				BL018.240			
								Coppia nominale Rated torque 24V		Coppia massima Peak torque 24V		Coppia nominale Rated torque 24V		Coppia massima Peak torque 24V	
Ns	in	ir	M _n [Nm]	Rd	R ₂ [N]	A ₂ [N]	Kg	[Nm]	[rpm]	[Nm]	[rpm]	[Nm]	[rpm]	[Nm]	[rpm]
1	4	3.70	2	0.80	160	50	0.4	0.37	1081	0.74	1081	0.55	1081	1.10	1081
	7	6.75						0.68	593	1.35	593	1.00	593	2.00	593
2	14	13.73	5	0.75	230	80	0.5	1.29	291	2.57	291	1.91	291	3.81	291
	25	25.01						2.34	160	4.69	160	3.47	160	6.94	160
	46	45.56						4.27	88	8.54	88	6.32	88	12.64	88
3	68	68.06	10	0.70	300	110	0.6	5.96	59	11.91	59	8.81	59	17.63	59
	93	92.70						8.11	43	16.22	43	12.00	43	24.01	43
	169	168.84						14.77	24	29.55	24	21.86	24	43.73	24
	308	307.54						26.91	13	53.82	13	39.83	13	79.65	13

P42								BL012.240				BL018.240			
								Coppia nominale Rated torque 24V		Coppia massima Peak torque 24V		Coppia nominale Rated torque 24V		Coppia massima Peak torque 24V	
Ns	in	ir	M _n [Nm]	Rd	R ₂ [N]	A ₂ [N]	Kg	[Nm]	[rpm]	[Nm]	[rpm]	[Nm]	[rpm]	[Nm]	[rpm]
1	4	3.70	3	0.8	160	50	0.4	0.37	1081	0.74	1081	0.55	1081	1.10	1081
	7	6.75						0.68	593	1.35	593	1.00	593	2.00	593
2	14	13.73	7.5	0.75	230	80	0.5	1.29	291	2.57	291	1.91	291	3.81	291
	25	25.01						2.34	160	4.69	160	3.47	160	6.94	160
	46	45.56						4.27	88	8.54	88	6.32	88	12.64	88
3	68	68.06	15	0.7	300	110	0.6	5.96	59	11.91	59	8.81	59	17.63	59
	93	92.70						8.11	43	16.22	43	12.00	43	24.01	43
	169	168.84						14.77	24	29.55	24	21.86	24	43.73	24
	308	307.54						26.91	13	53.82	13	39.83	13	79.65	13

Nota: le caselle in colore grigio indicano il superamento della coppia massima sopportata dal riduttore per il servizio in S1.
Per vedere tutti i rapporti di riduzione disponibili, vedere tabella a pag. E3

N.B.: boxes in grey indicate that maximum torque withstood by gear reducer for service in S1 is exceeded.
See the table on page E3 for all available ratios.

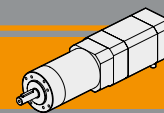

PK-P42 con motore brushless CC

PK-P42 with DC brushless motor

Tipo Type	Numero di poli Number of poles	Numero di fasi Number of phase	Tensione Rated voltage [V]	Numero di giri Rated speed [rpm]	Coppia nominale Rated torque [Nm]	Potenza nominale Rated power [W]
BL012.240	8	3	24	4000	0.125	52.5
BL018.240	8	3	24	4000	0.185	77.5
Tipo Type	Coppia massima Peak torque [Nm]	Corrente nominale Rated current [A]	Resistenza Resistance [ohm]	Induttanza Inductance [mH]	Corrente massima Peak current [A]	Peso Weight [kg]
BL012.240	0.25	3.5	0.8	1.2	7.0	0.45
BL018.240	0.37	5.0	0.55	0.8	10.0	0.65

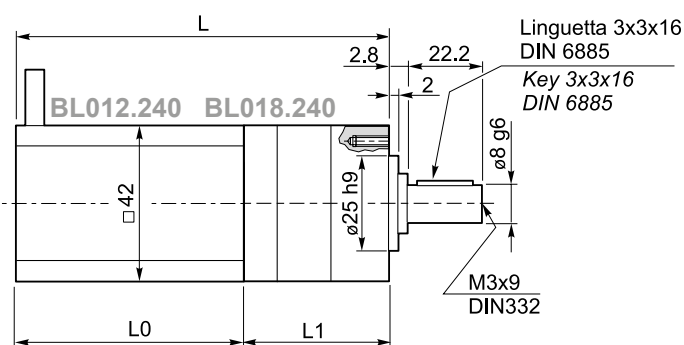
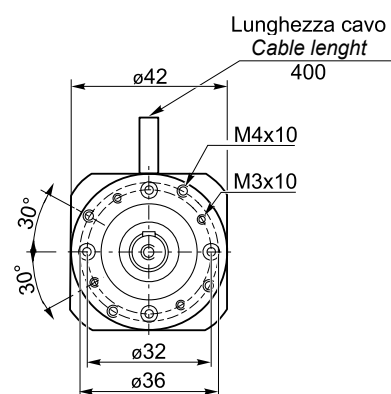

PK42BB P42	Ns	L1	BL012.240		BL018.240	
			L0	L	L0	L
	1	67	61	128	81	148
	2	80		141		161
	3	93		154		174

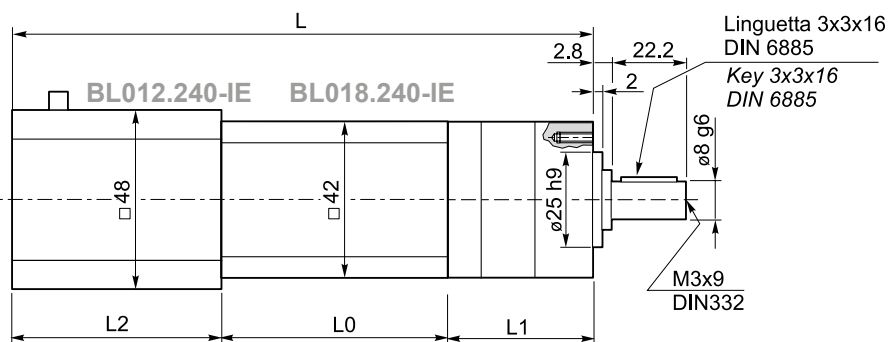
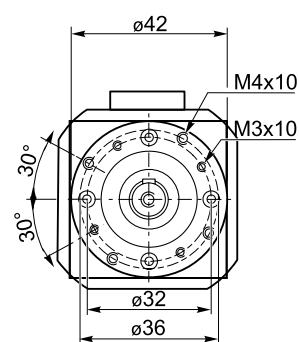

PK42BB P42	Ns	L1	BL012.240-IE			BL018.240-IE		
			L0	L	L2	L0	L	L2
	1	67	61	172	44	81	204	56
	2	80		185			217	
	3	93		198			230	

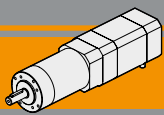

Micro motoriduttori brushless CC epicycloidali

Micro brushless DC planetary gearmotors

P42 con motore brushless CC

P42 with DC brushless motor

P42								BL025.24E			
								Coppia nominale Rated torque 24V		Coppia massima Peak torque 24V	
Ns	in	ir	M _n [Nm]	Rd	R ₂ [N]	A ₂ [N]	Kg	[Nm]	[rpm]	[Nm]	[rpm]
1	4	3.7	3	0.8	160	50	0.4	0.74	1081	1.48	1081
	7	6.75						1.35	593	2.70	593
2	14	13.73	7.5	0.75	230	80	0.5	2.57	291	5.14	291
	25	25.01						4.70	160	9.40	160
	46	45.56						8.54	88	17.08	88
3	68	68.06	15	0.7	300	110	0.6	11.90	59	23.80	59
	93	92.7						16.20	43	32.40	43
	169	168.84						29.55	24	59.10	24
	308	307.54						53.82	13	107.64	13

Nota: le caselle in colore grigio indicano il superamento della coppia massima sopportata dal riduttore per il servizio in S1.
Per vedere tutti i rapporti di riduzione disponibili, vedere tabella a pag. E3

*N.B.: boxes in grey indicate that maximum torque withstood by gear reducer for service in S1 is exceeded.
See the table on page E3 for all available ratios.*

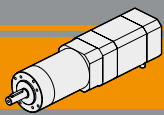

Micro motoriduttori brushless CC epicicloidali

Micro brushless DC planetary gearmotors

PK-P52 con motore brushless CC

PK-P52 with DC brushless motor

PK52BB								BL032.240				BL043.240			
								Coppia nominale Rated torque 24V		Coppia massima Peak torque 24V		Coppia nominale Rated torque 24V		Coppia massima Peak torque 24V	
Ns	in	ir	M _n [Nm]	Rd	R ₂ [N]	A ₂ [N]	Kg	[Nm]	[rpm]	[Nm]	[rpm]	[Nm]	[rpm]	[Nm]	[rpm]
1	4	3.70	3.0	0.75	200	60	0.4	0.89	811	1.78	811	1.19	811	2.39	811
	7	6.75						1.62	444	3.24	444	2.18	444	4.35	444
2	14	13.73	8.0	0.7	320	100	0.5	3.08	218	6.15	218	4.13	218	8.27	218
	25	25.01						5.60	120	11.20	120	7.53	120	15.06	120
	46	45.56						10.21	66	20.41	66	13.71	66	27.43	66
3	68	68.06	17.0	0.65	450	150	0.6	14.16	44	28.31	44	19.02	44	38.05	44
	93	92.70						19.28	32	38.56	32	25.91	32	51.82	32
	169	168.84						35.12	18	70.24	18	47.19	18	94.38	18
	308	307.54						63.97	10	127.94	10	85.96	10	171.91	10

Nota: è possibile alimentare i motori a 36V
Vedere dati coppia/giri a pag. D14 - D16

Note: Motors can be driven at 36V
Torque/speed motor data at pag. D14 - D16

P52								BL032.240				BL043.240			
								Coppia nominale Rated torque 24V		Coppia massima Peak torque 24V		Coppia nominale Rated torque 24V		Coppia massima Peak torque 24V	
Ns	in	ir	M _n [Nm]	Rd	R ₂ [N]	A ₂ [N]	Kg	[Nm]	[rpm]	[Nm]	[rpm]	[Nm]	[rpm]	[Nm]	[rpm]
1	4	3.70	4.0	0.8	200	60	0.7	0.95	811	1.90	811	1.28	811	2.55	811
	7	6.75						1.73	444	3.46	444	2.32	444	4.65	444
2	14	13.73	12.0	0.75	320	100	0.9	3.30	218	6.60	218	4.43	218	8.87	218
	25	25.01						6.00	120	12.00	120	8.06	120	16.13	120
	46	45.56						11.00	66	22.00	66	14.78	66	29.56	66
3	68	68.06	25.0	0.7	450	150	1.1	15.25	44	30.50	44	20.49	44	40.98	44
	93	92.70						20.80	32	41.60	32	27.95	32	55.90	32
	169	168.84						37.82	18	75.64	18	50.82	18	101.64	18
	308	307.54						68.9	10	137.80	10	92.58	10	185.17	10

Nota: le caselle in colore grigio indicano il superamento della coppia massima sopportata dal riduttore per il servizio in S1.
Per vedere tutti i rapporti di riduzione disponibili, vedere tabella a pag. E3

N.B.: boxes in grey indicate that maximum torque withstood by gear reducer for service in S1 is exceeded.
See the table on page E3 for all available ratios.

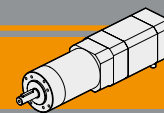

PK-P52 con motore brushless CC

PK-P52 with DC brushless motor

Tipo Type	Numero di poli Number of poles	Numero di fasi Number of phase	Tensione Rated voltage [V]	Numero di giri Rated speed [rpm]	Coppia nominale Rated torque [Nm]	Potenza nominale Rated power [W]
BL032.240	4	3	24	3000	0.32	100
BL043.240	4	3	24	3000	0.43	130
Tipo Type	Coppia massima Peak torque [Nm]	Corrente nominale Rated current [A]	Resistenza Resistance [ohm]	Induttanza Inductance [mH]	Corrente massima Peak current [A]	Peso Weight [kg]
BL032.240	0.64	5.0	0.45	1.4	10.0	1.0
BL043.240	0.86	6	0.35	1	12.0	1.25

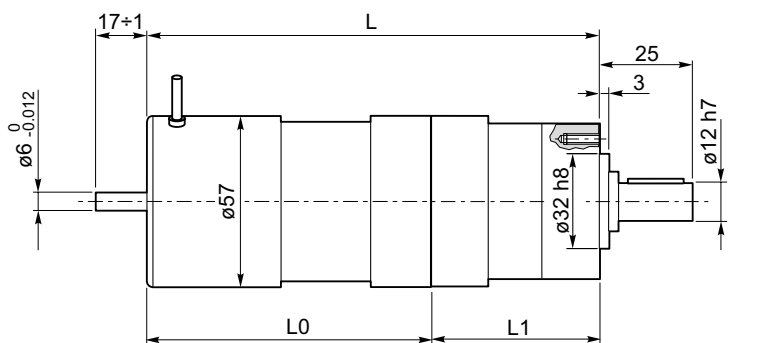
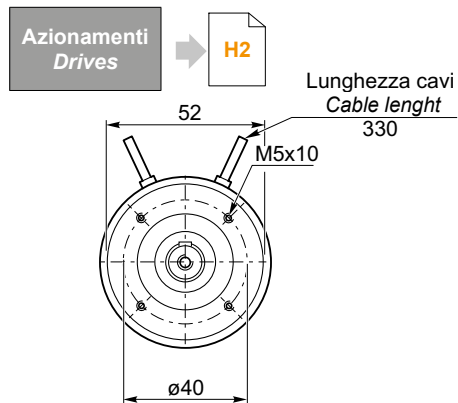

Encoder → **I2**

Per montaggio encoder serve flangia AS294
Encoder assembling needs flange AS294

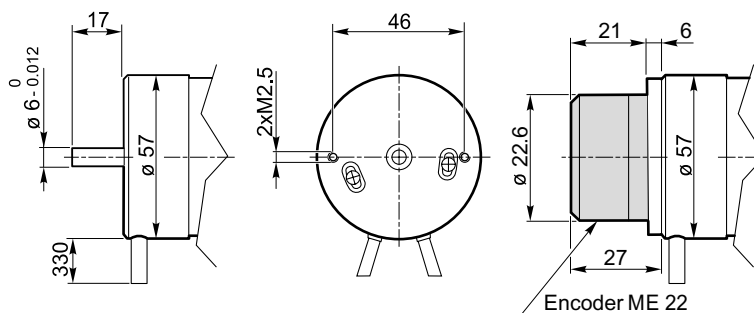

Freno / Brake → **F14**

PK52BB P52	Ns	L1	BL032.240		BL043.240	
			L0	L	L0	L
	1	78	95	173	115	193
	2	92		187		207
	3	106		201		221

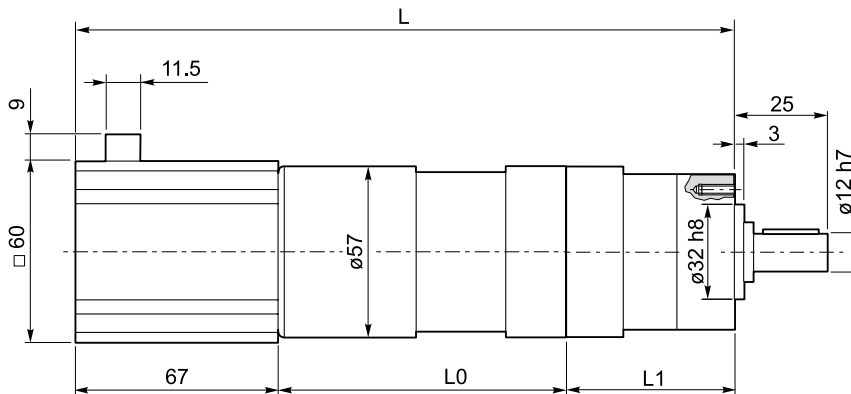
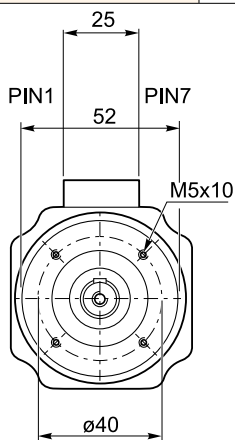

PK52BB P52	Ns	L1	BL032.240-IE		BL043.240-IE	
			L0	L	L0	L
	1	78	95	240	115	260
	2	92		254		274
	3	106		268		288

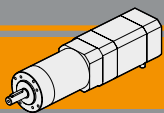

Micro motoriduttori brushless CC epicycloidali

Micro brushless DC planetary gearmotors

P62 con motore brushless CC

P62 with DC brushless motor

P62								BL032.240				BL043.240			
								Coppia nominale Rated torque 24V		Coppia massima Peak torque 24V		Coppia nominale Rated torque 24V		Coppia massima Peak torque 24V	
Ns	in	ir	M _n [Nm]	Rd	R ₂ [N]	A ₂ [N]	Kg	[Nm]	[rpm]	[Nm]	[rpm]	[Nm]	[rpm]	[Nm]	[rpm]
1	4	3.70	8.0	0.80	240	70	0.8	0.95	811	1.90	811	1.28	811	2.55	811
	7	6.75						1.73	444	3.46	444	2.32	444	4.65	444
2	14	13.73	25	0.75	360	100	1.2	3.30	218	6.60	218	4.43	218	8.87	218
	25	25.01						6.00	120	12.00	120	8.06	120	16.13	120
	46	45.56						11.00	66	22.00	66	14.78	66	29.56	66
3	68	68.06	50	0.70	520	150	1.6	15.25	44	30.50	44	20.49	44	40.98	44
	93	92.70						20.80	32	41.60	32	27.95	32	55.90	32
	169	168.84						37.82	18	75.64	18	50.82	18	101.64	18
	308	307.54						68.9	10	137.80	10	92.58	10	185.17	10

Nota: le caselle in colore grigio indicano il superamento della coppia massima sopportata dal riduttore per il servizio in S1.
Per vedere tutti i rapporti di riduzione disponibili, vedere tabella a pag. E3

*N.B.: boxes in grey indicate that maximum torque withstood by gear reducer for service in S1 is exceeded.
See the table on page E3 for all available ratios.*

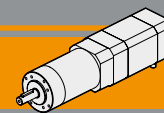

P62 con motore brushless CC

P62 with DC brushless motor

Tipo Type	Numero di poli Number of poles	Numero di fasi Number of phase	Tensione Rated voltage [V]	Numero di giri Rated speed [rpm]	Coppia nominale Rated torque [Nm]	Potenza nominale Rated power [W]
BL032.240	4	3	24	3000	0.32	100
BL043.240	4	3	24	3000	0.43	130
Tipo Type	Coppia massima Peak torque [Nm]	Corrente nominale Rated current [A]	Resistenza Resistance [ohm]	Induttanza Inductance [mH]	Corrente massima Peak current [A]	Peso Weight [kg]
BL032.240	0.64	5.0	0.45	1.4	10.0	1.0
BL043.240	0.86	6	0.35	1	12.0	1.25

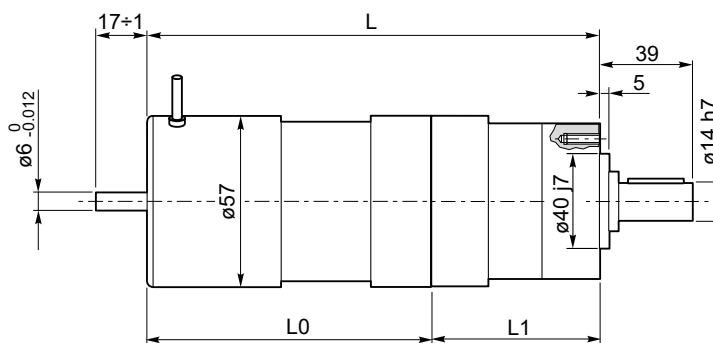
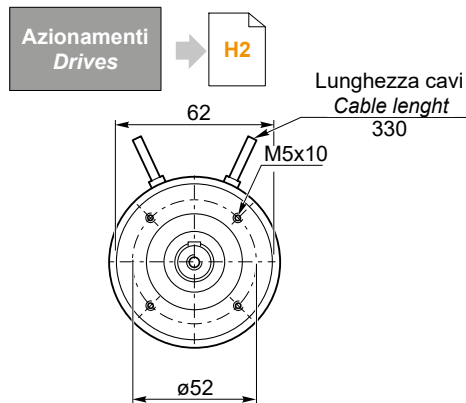

Encoder → I2
Per montaggio encoder serve flangia AS294
Encoder assembling needs flange AS294

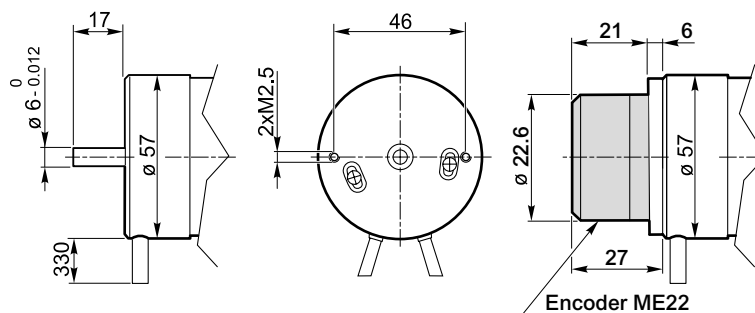

Freno / Brake → F14

P62	Ns	L1	BL032.240		BL043.240	
			L0	L	L0	L
	1	79	95	174	115	194
	2	95		190		210
	3	111		206		226

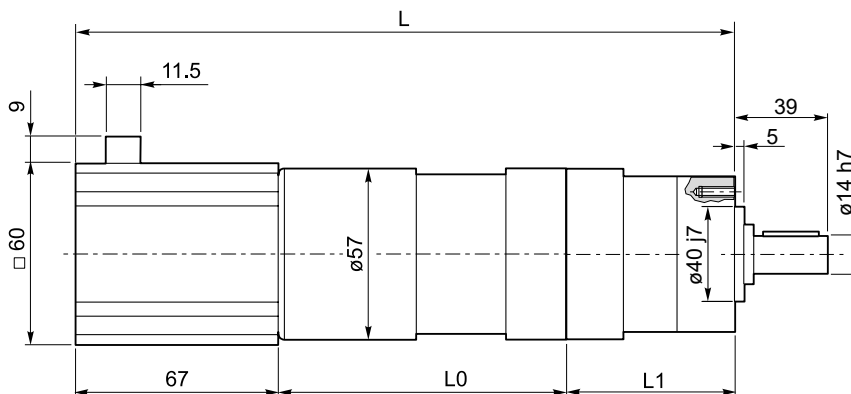
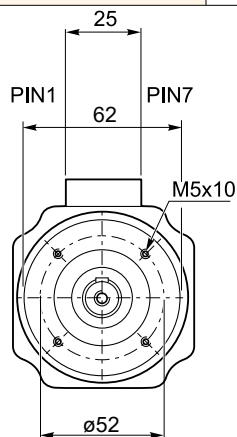

P62	Ns	L1	BL032.240-IE		BL043.240-IE	
			L0	L	L0	L
	1	79	95	241	115	261
	2	95		257		277
	3	111		273		293

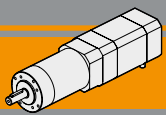

Freno

Brake

Freno / Brake

BL032...BR
BL043...BR

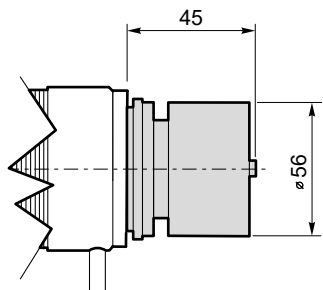

Freno con leva di sblocco/ Brake with hand release

BL032...BRL
BL043...BRL

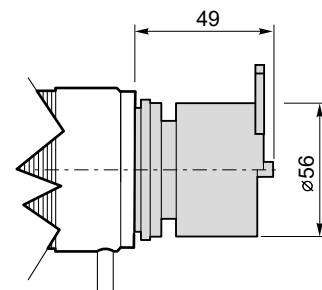
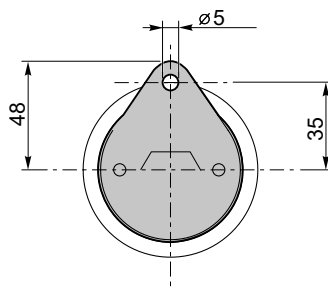

	P_n [W]	V [V]	M_n [Nm]	n₁ [min ⁻¹]
Caratteristiche del freno / Break features	14	12	2	3000
		24		

BL070...BR

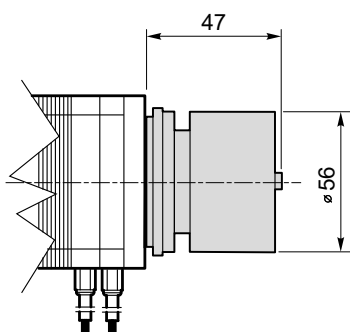

BL070...BRL

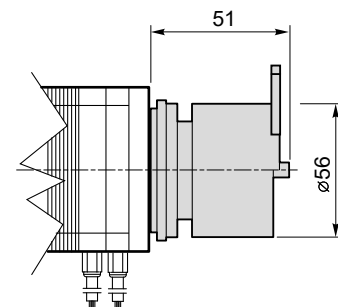
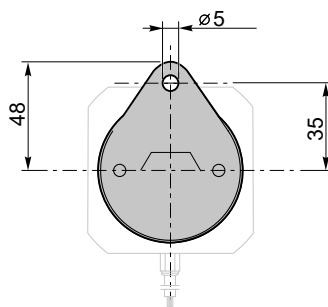

	P_n [W]	V [V]	M_n [Nm]	n₁ [min ⁻¹]
Caratteristiche del freno / Break features	14	12	2	3000
		24		

Micro motoriduttori brushless CC a vite senza fine Micro brushless DC wormgearmotors

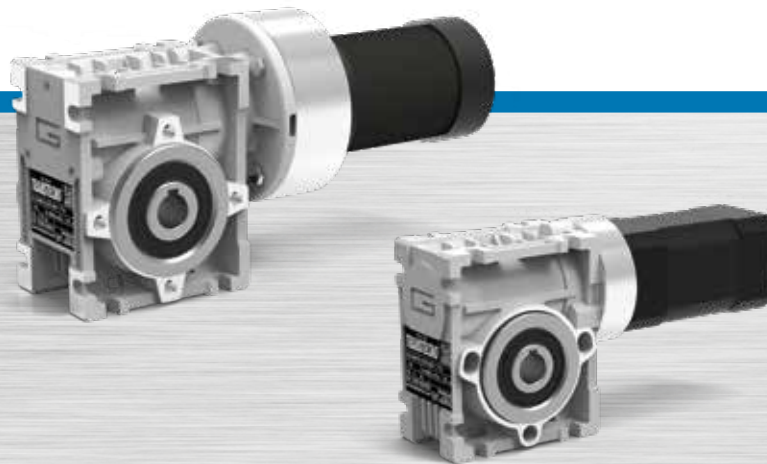

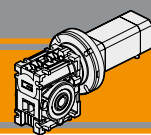

Indice	Index	Pag. Page
Caratteristiche tecniche	<i>Technical features</i>	G2
Designazione	<i>Classification</i>	G2
Simbologia	<i>Symbols</i>	G2
Lubrificazione	<i>Lubrication</i>	G2
Carichi radiali	<i>Radial loads</i>	G3
Dati di dentatura	<i>Toothing data</i>	G3
Rendimento	<i>Efficiency</i>	G3
CM026 con motore brushless	<i>CMn6 with brushless motor</i>	G4
CM030 con motore brushless	<i>CM30 with brushless motor</i>	G6
Dimensioni	<i>Dimensions</i>	G8
Opzioni	<i>Options</i>	G8
Accessori	<i>Accessories</i>	G9

Questa sezione annulla e sostituisce ogni precedente edizione o revisione. Qualora questa sezione non Vi sia giunta in distribuzione controllata, l'aggiornamento dei dati ivi contenuto non è assicurato. **In tal caso la versione più aggiornata è disponibile sul nostro sito internet www.intecno-srl.com**

*This section replaces any previous edition and revision. If you obtained this catalogue other than through controlled distribution channels, the most up to date content is not guaranteed. **In this case the latest version is available on our web site www.intecno-srl.com***

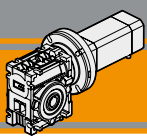

Micro motoriduttori brushless CC a vite senza fine Micro brushless DC wormgearmotors

Caratteristiche tecniche

Technical features

Le caratteristiche principali dei motoriduttori brushless CC a vite senza fine della serie CM sono:

The main features of brushless DC wormgearmotors range CM are:

- Alimentazione in bassa tensione 24/36 Vcc
- Possibilità di montaggio encoder
- Coppie motore disponibili da 0,12 a 0,43Nm
- Elettronica di comando integrata IE (opzionale)
- Carcasce dei riduttori in pressofusione di alluminio
- Lubrificazione permanente con olio sintetico
- Low voltage power supply 24/36 Vdc
- Suitable for encoder assembly
- Motor torque ratings available from 0,12 up to 0,43Nm
- Built in electronic drives IE (optional)
- Die-cast aluminium housings
- Permanent synthetic oil long life lubrication

Designazione

Classification

RIDUTTORE / GEARBOX				MOTORE / MOTOR		
CM	026	20	U	BL012.240	24V	IE
Tipo Type	Grandezza Size	Rapporto in Ratio in	Versione Version	Tipo Type	Tensione Voltage	Opzioni Options
CM	026 030	Vedere tabelle See tables	U F	BL012.240 BL018.240 BL025.24E BL032.240 BL043.240	24V 36V	IE Encoder 

Versione Riduttore
Gearbox Version

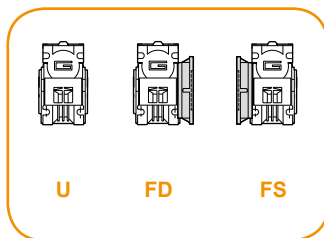

Simbologia

Symbols

Ns	n° stadi / No. stages	Pn	[W]	Potenza nominale / Nominal power
in	rapporto nominale / nominal ratio	V	[V]	Tensione / Voltage
ir	rapporto reale / real ratio	I	[A]	Assorbimento / Current
M _n	[Nm] coppia in uscita in funzionamento continuativo S1 output torque for continuous operation S1	IC		Classe di isolamento termico / Thermal insulation class
Rd	rendimento dinamico / efficiency	FF		Fattore di forma / Form factor
R ₂	[N] massimo carico radiale al centro dell'albero uscita max. radial load at output shaft centre	n ₁	[Rpm]	Giri / Speed
A ₂	[N] massimo carico assiale / max. axial load	IP		Grado di protezione / Enclosure protection
		Kg		Peso / Weight

Lubrificazione

Lubrication

I riduttori a vite senza fine della serie CM026 e CM030 sono lubrificati a vita con olio sintetico di viscosità 320 e possono essere installati in qualunque posizione di montaggio.

Temperatura ambiente 0 ÷ 40 °C (in assenza di congelamento ed in assenza di condensa).

Per temperature diverse, contattare nostro UT.

Permanent synthetic oil long-life lubrication allow to use CM026 and CM030 wormgearbox range in all mounting position.

Ambient temperature 0 ÷ 40 °C (in the absence of freezing and condensation).

For temperature outside this range please contact our technical dept.

	Quantità di olio (litri) / Oil quantity (litres)					
	B3	B8	B6	B7	V5	V6
CM026	0.015					
CM030	0.03					

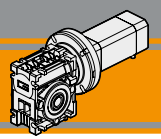

Carichi radiali

Radial loads

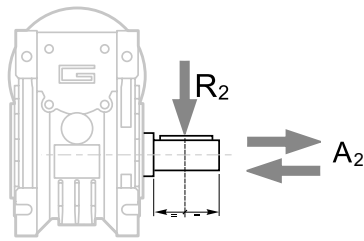

$$A_2 = R_2 \times 0.2$$

n ₂ [min ⁻¹]	R ₂ [N]	
	CM026	CM030
187	400	674
140	490	743
93	580	851
70	610	936
56	610	1008
47	610	1069
35	610	1179
28	610	1270
23	610	1356
18	610	1471
14	610	1600

Quando il carico radiale risultante non è applicato sulla mezza-
ria dell'albero occorre calcolare quello effettivo con la seguente
formula:

When the resulting radial load is not applied on the centre line
of the shaft it is necessary to calculate the effective load with the
following formula:

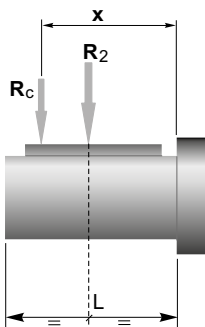

$$R_c = \frac{R_2 \cdot a}{(b+x)} \leq R_{2MAX}$$

$$R \leq R_c$$

a, b = valori riportati nella tabella
a, b = values given in the table

	CM	
	026	030
a	56	65
b	43	50
R _{2MAX}	610	1600

Dati di dentatura

Toothing data

	Dati della coppia vite-corona Worm wheel data	Rapporto / Ratio											
		5	7.5	10	15	20	25	30	40	50	60	80	100
CM026	Z	6	4	3	2	2		1	1	1	1		
	β	34° 35'	24° 41'	19° 1'	12° 57'	10° 30'		6° 33'	5° 17'	4° 26'	3° 49'		
CM030	Z	6	4	3	2	2	2	1	1	1	1	1	1
	β	27° 4'	24° 28'	18° 50'	12° 49'	10° 23'	8° 43'	6° 29'	5° 14'	4° 23'	3° 46'	2° 57'	2° 25'

Rendimento

Efficiency

	n ₁ [min ⁻¹]	Rendimento Efficiency	Rapporto / Ratio											
			5	7.5	10	15	20	25	30	40	50	60	80	100
CM026	2800	Rd	0.89	0.87	0.85	0.83	0.80		0.73	0.68	0.64	0.60		
		Rs	0.72	0.71	0.68	0.61	0.56		0.46	0.41	0.36	0.34		
CM030	2800	Rd	0.89	0.88	0.86	0.84	0.81	0.78	0.74	0.70	0.65	0.62	0.57	0.52
		Rs	0.72	0.67	0.63	0.55	0.50	0.43	0.39	0.35	0.31	0.27	0.23	0.21

Reversibilità e irreversibilità

Reversibility and irreversibility

La tabella sottostante riporta a titolo puramente
indicativo i vari gradi di reversibilità/irreversibilità
nei riduttori a vite senza fine in funzione del rendi-
mento dinamico Rd e statico Rs.

The table below is provided for reference purposes
only. It contains the various degrees of reversibi-
lity/irreversibility of wormgearboxes in relation to
dynamic Rd and static Rs efficiency.

Rd	Reversibilità e irreversibilità dinamica	Dynamic reversibility and irreversibility
> 0.60	Reversibilità dinamica	Dynamic reversibility
0.50 - 0.60	Reversibilità dinamica incerta	Uncertain dynamic reversibility
0.40 - 0.50	Buona irreversibilità dinamica	Good dynamic irreversibility
<0.40	Irreversibilità dinamica	Dynamic irreversibility
Rs	Reversibilità e irreversibilità statica	Static reversibility and irreversibility
> 0.55	Reversibilità statica	Static reversibility
0.50 - 0.55	Reversibilità statica incerta	Uncertain static reversibility
<0.50	Irreversibilità statica	Static irreversibility

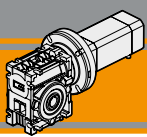

Micro motoriduttori brushless CC a vite senza fine

Micro brushless DC wormgearmotors

CM026 con motore brushless CC

CM026 with DC brushless motor

CM026			BL012.240				BL018.240					
n ₁ =3000 rpm			Coppia nominale Rated torque 24V		Coppia massima Peak torque 24V		Coppia nominale Rated torque 24V		Coppia massima Peak torque 24V			
			[Nm]	[rpm]	[Nm]	[rpm]	[Nm]	[rpm]	[Nm]	[rpm]		
ir	M _n [Nm]	Kg	5	10	0.56	800	1.11	800	0.82	800	1.65	800
7.5	11		0.82	533	1.63	533	1.21	533	2.41	533		
10	11		1.06	400	2.13	400	1.57	400	3.15	400		
15	11		1.56	267	3.11	267	2.30	267	4.61	267		
20	11		2.00	200	4.00	200	2.96	200	5.92	200		
30	12		2.74	133	5.48	133	4.05	133	8.10	133		
40	11		3.40	100	6.80	100	5.03	100	10.06	100		
50	10		4.00	80	8.00	80	5.92	80	11.84	80		
60	9		4.50	67	9.00	67	6.66	67	13.32	67		

Nota: le caselle in colore grigio indicano il superamento della coppia massima sopportata dal riduttore per il servizio in S1.

N.B.: boxes in grey indicate that maximum torque withstood by gear reducer for service in S1 is exceeded.

Tipo Type	Numero di poli Number of poles	Numero di fasi Number of phase	Tensione Rated voltage [V]	Numero di giri Rated speed [rpm]	Coppia nominale Rated torque [Nm]	Potenza nominale Rated power [W]
BL012.240	8	3	24	4000	0.125	52.5
BL018.240	8	3	24	4000	0.185	77.5
Tipo Type	Coppia massima Peak torque [Nm]	Corrente nominale Rated current [A]	Resistenza Resistance [ohm]	Induttanza Inductance [mH]	Corrente massima Peak current [A]	Peso Weight [kg]
BL012.240	0.25	3.5	0.8	1.2	7.0	0.45
BL018.240	0.37	5.0	0.55	0.8	10.0	0.65

Azionamenti
Drives

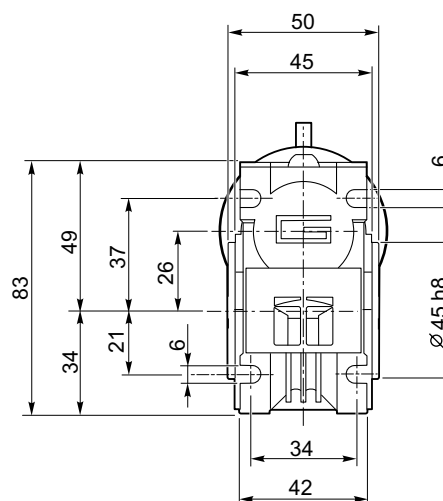
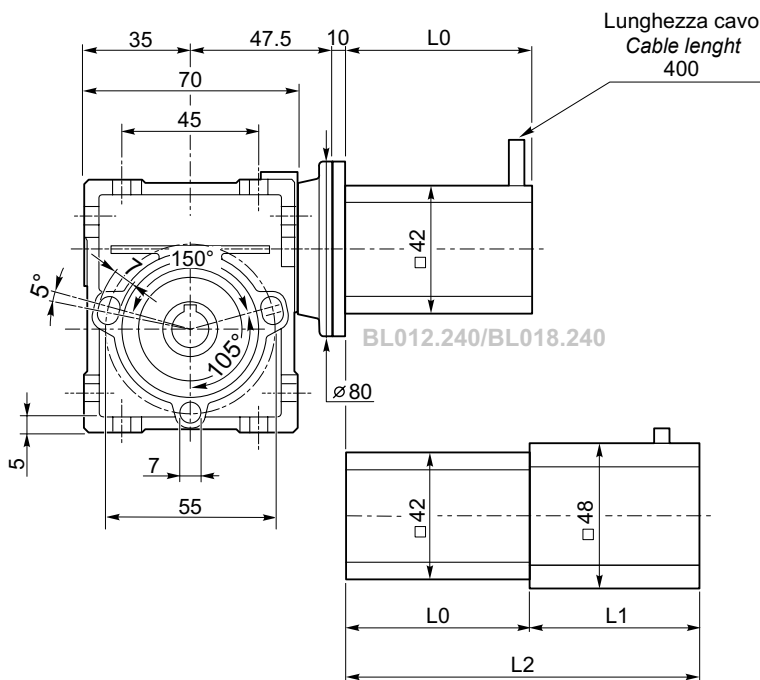

Tipo Type	L0	L1	L2
BL012.240	61	-	-
BL012.240-IE	61	44	105
BL018.240	81	-	-
BL018.240-IE	81	56	137

BL012.240-IE/BL018.240-IE

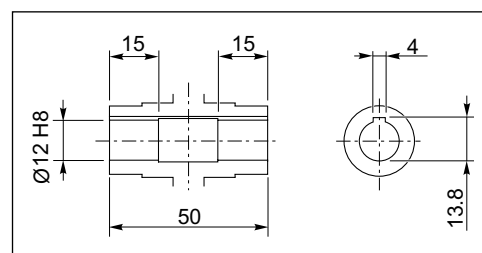

Albero lento cavo / Hollow output shaft

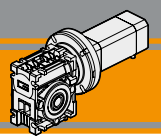

CM026 con motore brushless CC

CM026 with DC brushless motor

CM026			BL025.24E			
n ₁ =3000 rpm			Coppia nominale Rated torque 24V		Coppia massima Peak torque 24V	
ir	M _n [Nm]	Kg	[Nm]	[rpm]	[Nm]	[rpm]
5	10	0.8	1.11	800	2.23	800
7.5	11		1.63	533	3.26	533
10	11		2.13	400	4.25	400
15	11		3.11	267	6.23	267
20	11		4.00	200	8.00	200
30	12		5.48	133	10.95	133
40	11		6.80	100	13.60	100
50	10		8.00	80	16.00	80
60	9		9.00	67	18.00	67

Nota: le caselle in colore grigio indicano il superamento della coppia massima sopportata dal riduttore per il servizio in S1.

N.B.: boxes in grey indicate that maximum torque withstood by gear reducer for service in S1 is exceeded.

Tipo Type	Numero di poli Number of poles	Numero di fasi Number of phase	Tensione Rated voltage [V]	Numero di giri Rated speed [rpm]	Coppia nominale Rated torque [Nm]	Potenza nominale Rated power [W]
BL025.24E	8	3	24	4000	0.25	105
Tipo Type	Coppia massima Peak torque [Nm]	Corrente nominale Rated current [A]	Resistenza Resistance [ohm]	Induttanza Inductance [mH]	Corrente massima Peak current [A]	Peso Weight [kg]
BL025.24E	0.5	7.0	0.3	0.5	21	0.8

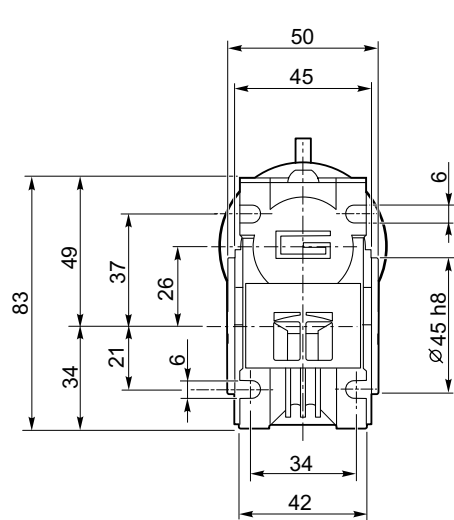
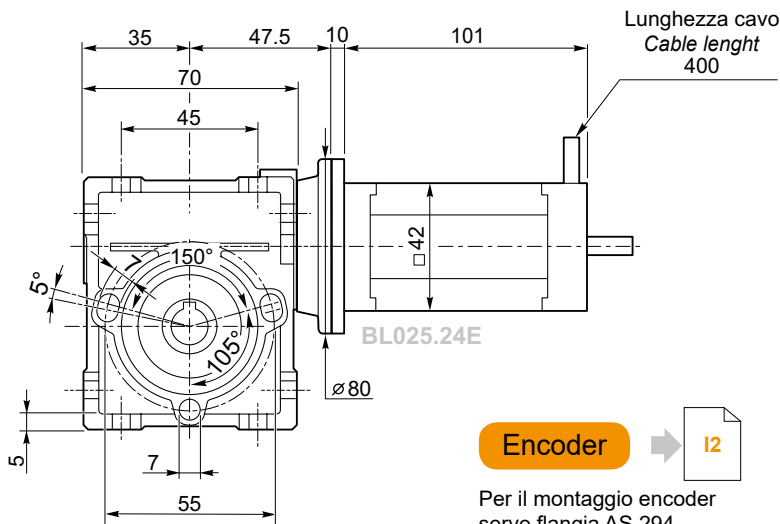

Per il montaggio encoder serve flangia AS 294
Encoder assembling needs flange AS 294

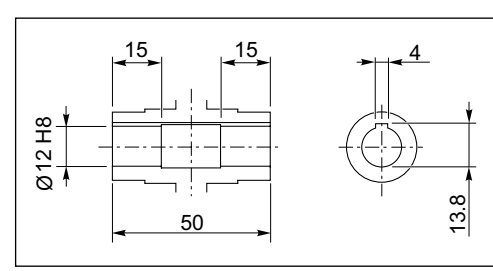
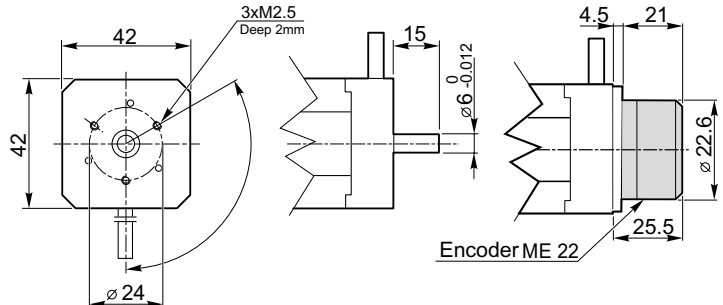

Albero lento cavo / Hollow output shaft

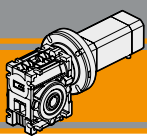

Micro motoriduttori brushless CC a vite senza fine

Micro brushless DC wormgearmotors

CM030 con motore brushless CC

CM30 with DC brushless motor

CM030			BL032.240			
n ₁ =3000 rpm			Coppia nominale Rated torque 24V		Coppia massima Peak torque 24V	
ir	M _n [Nm]	Kg	[Nm]	[rpm]	[Nm]	[rpm]
5	13	1.2	1.42	600	2.84	600
7.5	15		2.11	400	4.22	400
10	16		2.75	300	5.50	300
15	16		4.03	200	8.06	200
20	14		5.18	150	10.36	150
25	15		6.24	120	12.48	120
30	18		7.10	100	14.20	100
40	16		8.96	75	17.92	75
50	15		10.4	60	20.80	60
60	14		11.90	50	23.80	50
80	12		14.59	38	29.18	38
100	11		16.64	30	33.28	30

Nota: le caselle in colore grigio indicano il superamento della coppia massima sopportata dal riduttore per il servizio in S1.

N.B.: boxes in grey indicate that maximum torque withstood by gear reducer for service in S1 is exceeded.

Tipo Type	Numero di poli Number of poles	Numero di fasi Number of phase	Tensione Rated voltage [V]	Numero di giri Rated speed [rpm]	Coppia nominale Rated torque [Nm]	Potenza nominale Rated power [W]
BL032.240	4	3	24	3000	0.32	100
Tipo Type	Coppia massima Peak torque [Nm]	Corrente nominale Rated current [A]	Resistenza Resistance [ohm]	Induttanza Inductance [mH]	Corrente massima Peak current [A]	Peso Weight [kg]
BL032.240	0.64	5.0	0.45	1.4	10.0	1.0

Nota: è possibile alimentare i motori a 36V
Vedere dati coppia/giri a pag. D14 - D16

Note: Motors can be driven at 36V
Torque/speed motor data at pag. D14 - D16

Azionamenti
Drives

H2

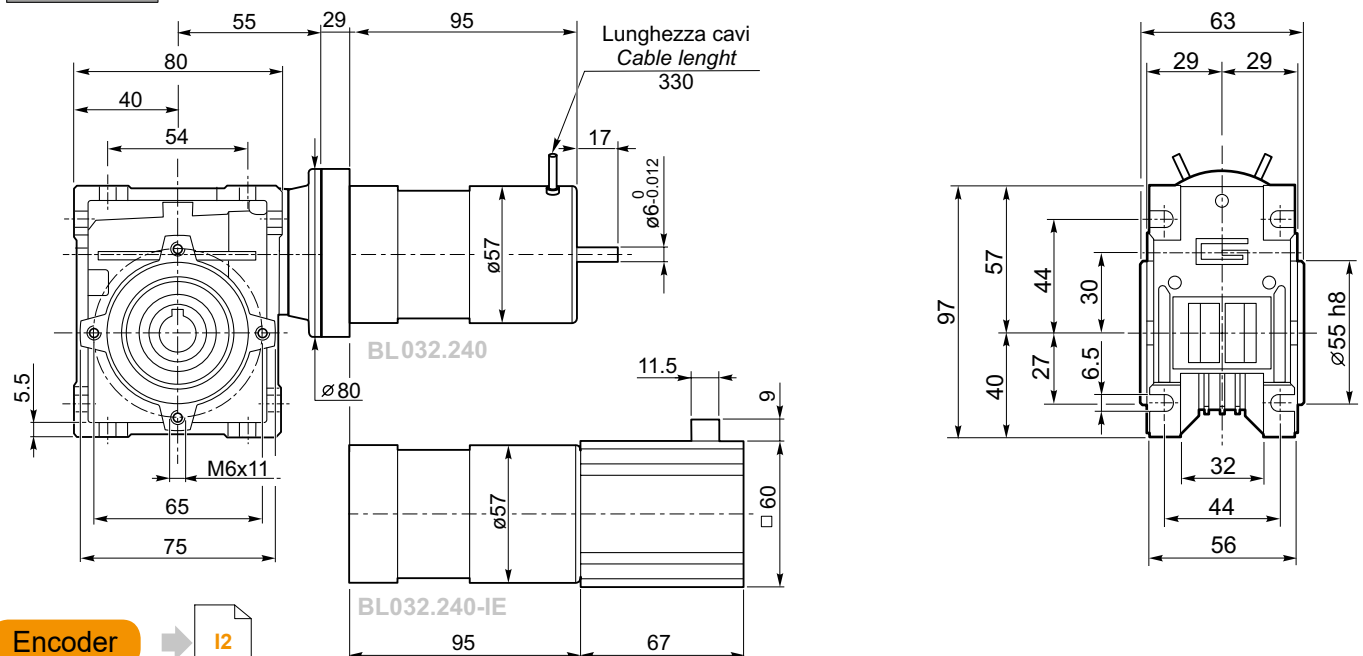

Encoder

I2

Per il montaggio encoder
serve flangia AS 294
Encoder assembling
needs flange AS 294

Freno / Brake

G10

Albero lento cavo / Hollow output shaft

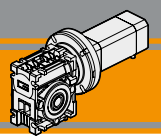

CM030 con motore brushless CC

CM30 with DC brushless motor

CM030			BL043.240			
n ₁ =3000 rpm			Coppia nominale Rated torque 24V		Coppia massima Peak torque 24V	
ir	M _n [Nm]	Kg	[Nm]	[rpm]	[Nm]	[rpm]
5	13	1.2	1.91	600	3.82	600
7.5	15		2.84	400	5.67	400
10	16		3.70	300	7.39	300
15	16		5.42	200	10.83	200
20	14		6.96	150	13.92	150
25	15		8.39	120	16.77	120
30	18		9.54	100	19.08	100
40	16		12.04	75	24.08	75
50	15		13.98	60	27.95	60
60	14		15.99	50	31.98	50
80	12		19.61	38	39.21	38
100	11		22.36	30	44.72	30

Nota: le caselle in colore grigio indicano il superamento della coppia massima sopportata dal riduttore per il servizio in S1.

N.B.: boxes in grey indicate that maximum torque withstood by gear reducer for service in S1 is exceeded.

Tipo Type	Numero di poli Number of poles	Numero di fasi Number of phase	Tensione Rated voltage [V]	Numero di giri Rated speed [rpm]	Coppia nominale Rated torque [Nm]	Potenza nominale Rated power [W]
BL043.240	4	3	24	3000	0.43	130
Tipo Type	Coppia massima Peak torque [Nm]	Corrente nominale Rated current [A]	Resistenza Resistance [ohm]	Induttanza Inductance [mH]	Corrente massima Peak current [A]	Peso Weight [kg]
BL043.240	0.86	6	0.35	1.0	12.0	1.25

Nota: è possibile alimentare i motori a 36V
Vedere dati coppia/giri a pag. D14 - D16

Note: Motors can be driven at 36V
Torque/speed motor data at pag. D14 - D16

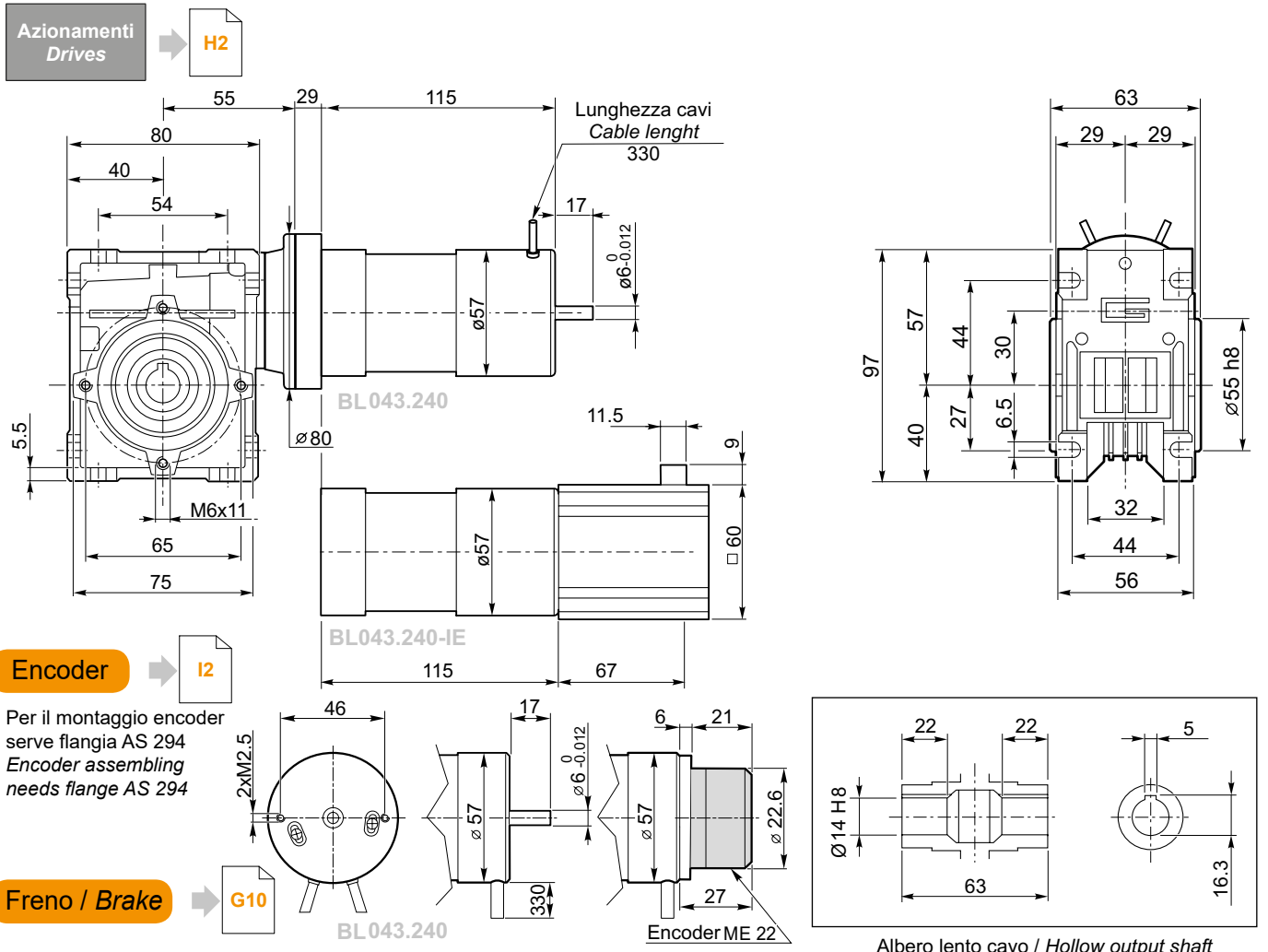

Brushless DC
CM

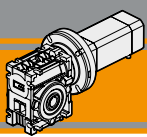

Micro motoriduttori brushless CC a vite senza fine Micro brushless DC wormgearmotors

Dimensioni

Dimensions

CM.../... F... Flange uscita / Output flanges

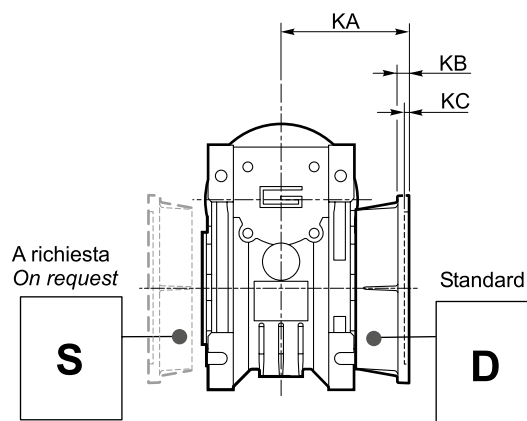
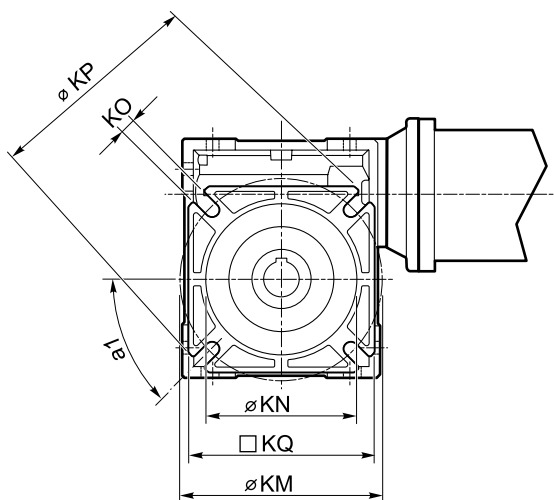

CM	CM..F								
	a1	KA	KB	KC	KM	KN _{H8}	KO	KP	KQ
026	45°	45	6	4.5	55-69	40	6.5(n.4)	75	70
030	45°	54.5	6	4	68	50	6.5(n.4)	80	70

Opzioni

Options

VS - Vite sporgente / Extended input shaft

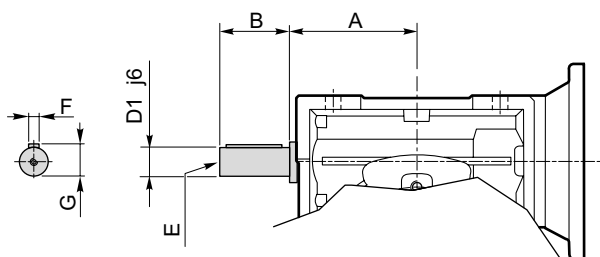

	A	B	D ₁ j6	E	F	G
CM 030	45	20	9	M4	3	10.2

SC - Safety cover

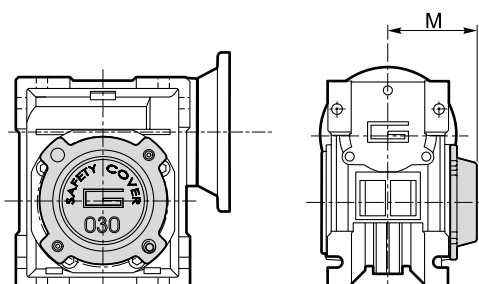

	M
CM 030	47

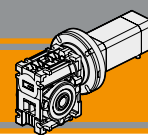

Accessori

Accessories

Albero lento

Output shaft

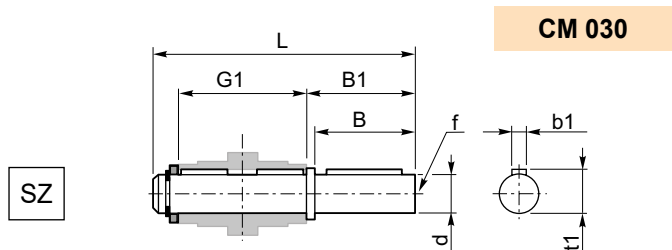
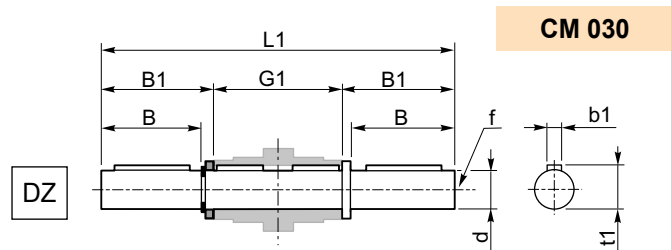

	d h7	B	B1	G1	L	L1	f	b1	t1
CM 030	14	30	32.5	63	102	128	M6	5	16

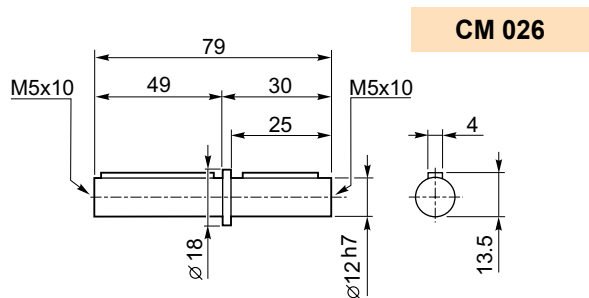

Braccio di reazione

Torque arm

	K1	G	KG	KH	R
CM 030	85	14	23	8	15

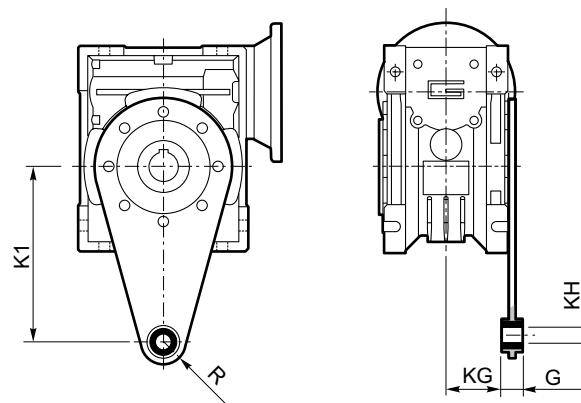

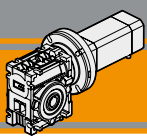

Freno

Brake

Freno / Brake

BL032...BR
BL043...BR

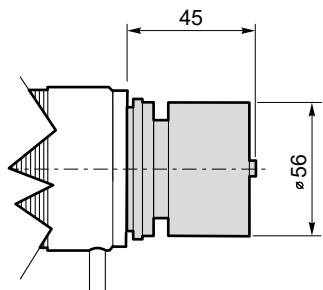

Freno con leva di sblocco/ Brake with hand release

BL032...BRL
BL043...BRL

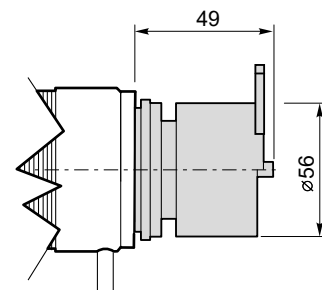
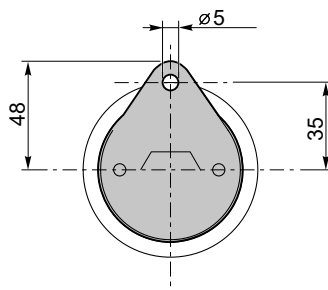

	P_n [W]	V [V]	M_n [Nm]	n₁ [min ⁻¹]
Caratteristiche del freno / Break features	14	12	2	3000
		24		

BL070...BR

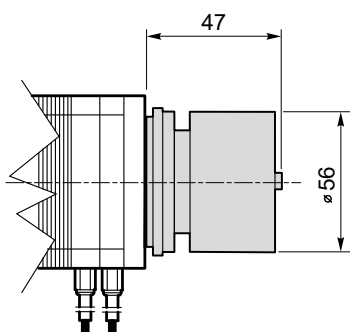

BL070...BRL

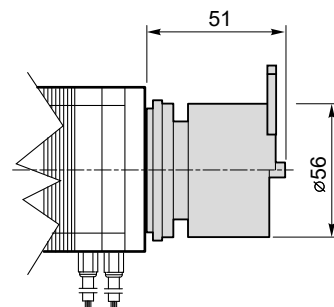
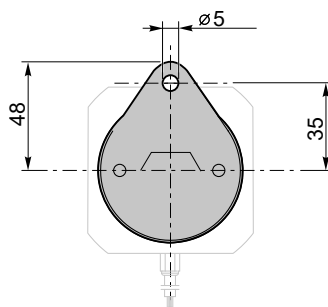

	P_n [W]	V [V]	M_n [Nm]	n₁ [min ⁻¹]
Caratteristiche del freno / Break features	14	12	2	3000
		24		

Azionamenti per motori CC e brushless CC DC and brushless DC motor control





	Indice	Index	Pag. Page
	Selezione azionamento	Drive selection	H2
	Selezione azionamento per motori CC	<i>DC motor drive selection guide</i>	
	Selezione azionamento per motori Brushless	<i>Brushless motor drive selection guide</i>	
PLN19-8	AZIONAMENTO UNIDIREZIONALE PWM PER MOTORI CC	SINGLE DIRECTION PWM CONTROL FOR DC MOTORS	
	Schema dei collegamenti	<i>Main connection diagram</i>	H3
	Caratteristiche tecniche	<i>Technical features</i>	H3
	Dimensioni	<i>Dimensions</i>	H4
	Opzioni	<i>Options</i>	H4
PLN20/40	AZIONAMENTO BIDIREZIONALE PWM PER MOTORI CC	BIDIRECTIONAL PWM CONTROL FOR DC MOTORS	
	Caratteristiche tecniche	<i>Technical features</i>	H5
	Dotazioni	<i>Equipment</i>	H5
	Dimensioni	<i>Dimensions</i>	H6
	Schema dei collegamenti	<i>Main connection diagram</i>	H7
BLD07-IT	AZIONAMENTO 4Q PER MOTORI BRUSHLESS	DRIVE 4Q FOR BRUSHLESS MOTORS	
	Caratteristiche tecniche	<i>Technical features</i>	H8
	Dimensioni	<i>Dimensions</i>	H9
	Collegamenti	<i>Connection</i>	H9
BLD10	AZIONAMENTO 4Q PER MOTORI BRUSHLESS	DRIVE 4Q FOR BRUSHLESS MOTORS	
	Caratteristiche standard	<i>Standard characteristic</i>	H11
	Dati tecnici principali	<i>Specifications</i>	H11
	Dimensioni	<i>Dimensions</i>	H12
	Collegamenti	<i>Connections</i>	H12
	Collegamenti per motori Brushless serie BL	<i>Connections for brushless motors BL series</i>	H13
	Collegamenti con altri componenti	<i>Connections with other devices</i>	H14
IE	Elettronica integrata per motori Brushless	Integrated electric control for Brushless motors	H15
	Collegamenti	<i>Connection</i>	

Questa sezione annulla e sostituisce ogni precedente edizione o revisione. Qualora questa sezione non Vi sia giunta in distribuzione controllata, l'aggiornamento dei dati ivi contenuto non è assicurato. **In tal caso la versione più aggiornata è disponibile sul nostro sito internet www.micro-intecno.com**

This section replaces any previous edition and revision. If you obtained this catalogue other than through controlled distribution channels, the most up to date content is not guaranteed. In this case the latest version is available on our web site www.micro-intecno.com



SELEZIONE AZIONAMENTO

DRIVE SELECTION

Selezione azionamento per motori CC

DC motor drive selection guide

Motori applicabili <i>Suitable motors</i>	Scheda / <i>type</i>	<i>Amps S1</i>	<i>Amps S2</i>
EC008.120	PLN19-8 - PLN20	0.80	1.40
EC008.240	PLN19-8 - PLN20	0.38	0.80
EC016.120	PLN19-8 - PLN20	1.4	2.4
EC016.240	PLN19-8 - PLN20	0.7	1.3
EC020.120	PLN19-8 - PLN20	3.2	4
EC020.24E	PLN19-8 - PLN20	1.5	2
EC030.240 / 24E	PLN19-8 - PLN20	2	3.5
EC035.120	PLN20	5.2	8
EC035.240	PLN19-8 - PLN20	2.6	4
EC050.12E	PLN20	6.8	9.4
EC050.24E	PLN19-8 - PLN20	3.4	4.7
EC070.12E	PLN20	8.4	11.8
EC070.24E	PLN19-8 - PLN20	4.2	5.9
EC100.120	PLN20	12	16.8
EC100.240 / 24E	PLN20	6	8.4
EC180.120	PLN40	21.5	30
EC180.240 / 24E	PLN20	10.8	15

Selezione azionamento per motore brushless

Brushless motor drive selection guide

Motori applicabili <i>Suitable motors</i>	Scheda / <i>Type</i>	<i>Amp nom</i>	<i>Amp picco</i>
BL005.240	BLD07-IT	1	3
BL012.240	BLD07-IT - BLD10	3.5	7
BL018.240	BLD07-IT - BLD10	5	10
BL025.24E	BLD07-IT - BLD10	7	14
BL032.240	BLD07-IT - BLD10	5	10
BL043.240	BLD07-IT - BLD10	7	14
BL070.48E	BLD10	7	14



PLN19-8

AZIONAMENTO UNIDIREZIONALE PWM PER MOTORI CC

SINGLE DIRECTION PWM CONTROL FOR DC MOTORS

Schema dei collegamenti

Main connection diagram

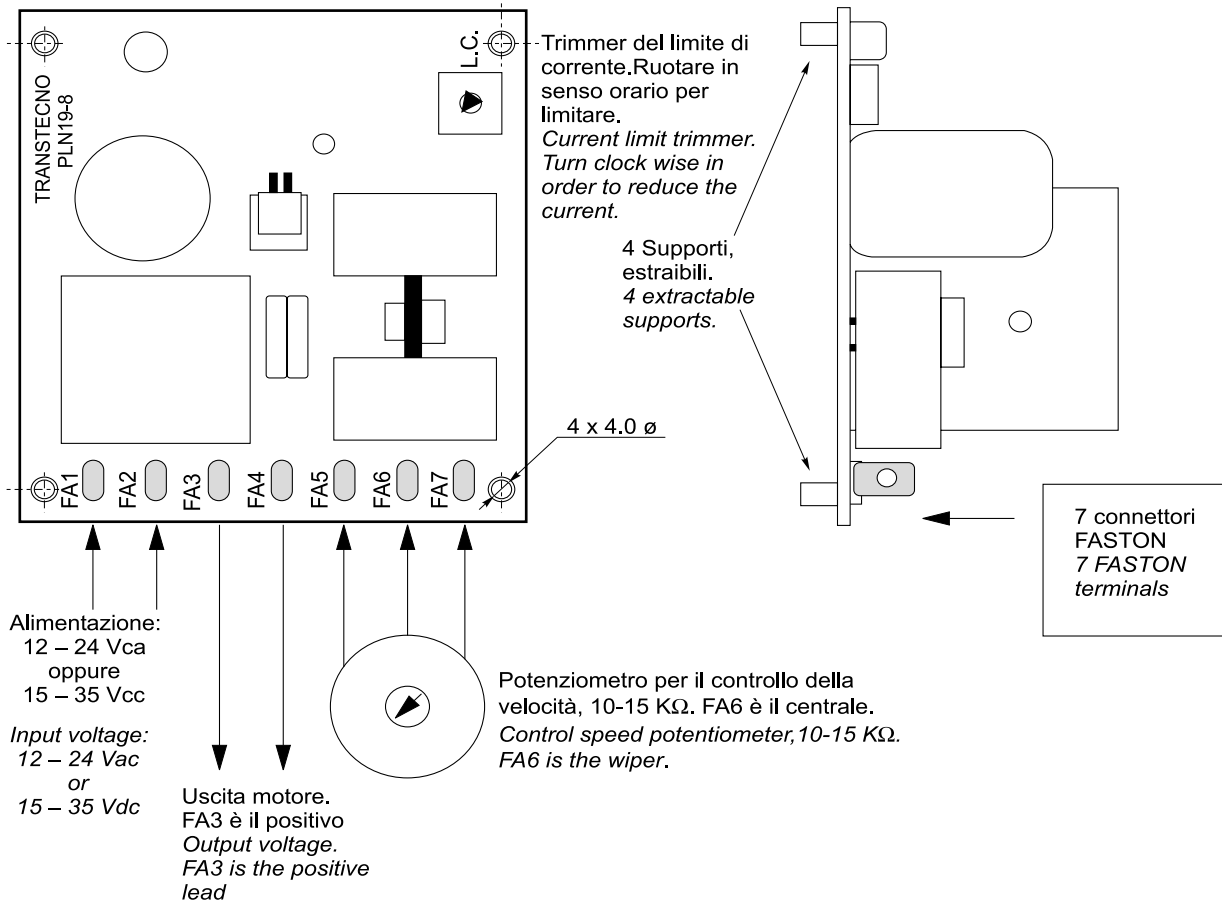

Attenzione: se si scollega il potenziometro con la scheda alimentata, il motore ruota alla velocità nominale.

Warning: if speed pot is disconnected when the board is powered, the motor runs at its maximum speed.

Caratteristiche tecniche

Technical features

- Alimentazione ai terminali FA1 e FA2:
12 – 24 Vca oppure 15 – 35 Vcc
- Regolazione della velocità mediante potenziometro 10K Ω
- Trimmer di Limitazione della corrente, per adattare la scheda anche a motori di piccole potenze. Per limitare l'erogazione di corrente, ruotare in senso orario il trimmer.
- Uscita motore ai terminali FA3 e FA4, regolabile da 0 a Vcc MAX che è proporzionale alla tensione di ingresso. Con 35 Vcc di alimentazione, l'uscita MAX è circa 30 Vcc.
- Corrente di uscita (NOTA1):
- Massima corrente ammessa: 8 A in ambiente ventilato, servizio continuo.
- Peso: 120 g.
- Line voltage at terminals FA1 and FA2:
12 – 24 Vac or 15 – 35 Vdc
- The speed of the drive is to be controlled by potentiometer, 10K Ω
- Current Limit trimmer, in order to suit the board for small motors. In order to limit the current, turn clock wise the trimmer.
- Output voltage from terminals FA3 and FA4, from 0 up to Vdc MAX which is proportional to the input voltage. With 35 Vdc input voltage, the max output voltage is about 30 Vdc.
- Output current (NOTE1):
- Maximum output current allowed: 8 A in a ventilated environment, continuous duty
- Weight: 120 g.



PLN19-8

**AZIONAMENTO UNIDIREZIONALE PWM
PER MOTORI CC**

**SINGLE DIRECTION PWM CONTROL
FOR DC MOTORS**

Dimensioni

Dimensions

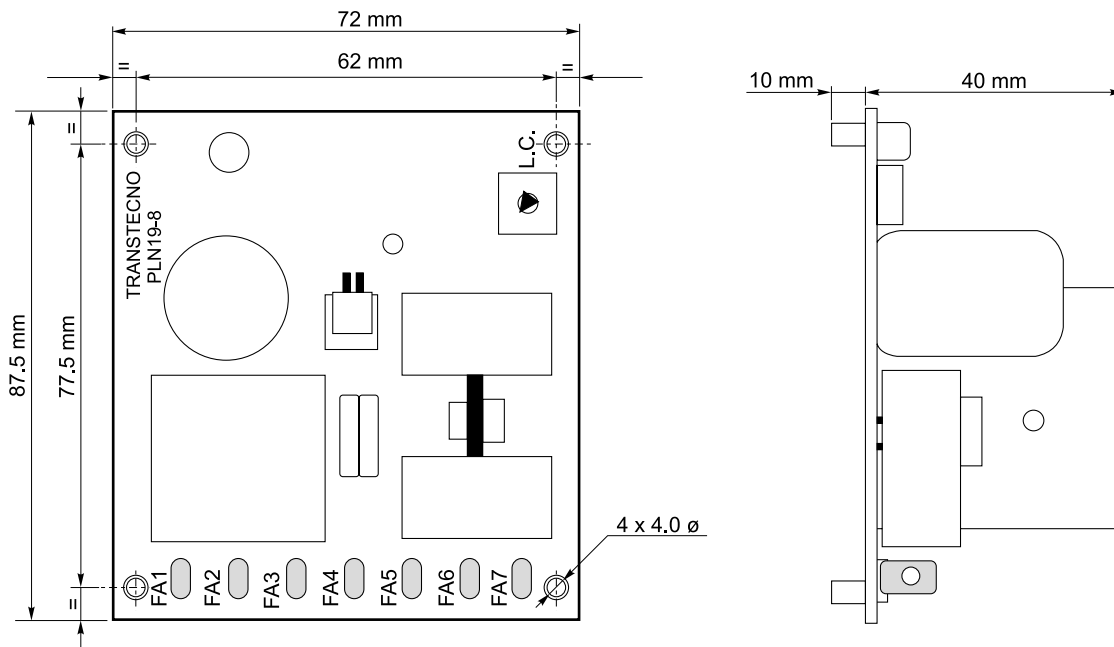

Opzioni

Options

1. Potenzimetro 10 KΩ
2. Supporto per montaggio su guida DIN

1. Speed potentiometer 10 KΩ
2. DIN mounting support

NOTA 1: il valore massimo di corrente motore deve essere utilizzato in **ambiente ventilato**.

In ambienti non ventilati e per temperatura ambiente di 45 °C, ridurre la corrente motore massima a 4 A; servizio continuo.

NOTE 1: the maximum output current value is available to be used **in a ventilated environment**. Reduce the maximum output current down to 4 A if environment is not ventilated and its temperature is about 45 °C; continuous duty.

NOTA 2: La scheda viene fornita completa di datasheet tecnico e confezione di imballo.

NOTE 2: the board is supplied with the technical datasheet and the shipping box.



PLN20/40

**AZIONAMENTO BIDIREZIONALE PWM
PER MOTORI CC**

**BIDIRECTIONAL PWM CONTROL
FOR DC MOTORS**

Caratteristiche tecniche

Technical features

- Scheda bidirezionale a transistor a ricircolo di corrente.
 - Selezionabili i seguenti parametri (mediante trimmer):
 - rampa di accelerazione: 0.5 - 10 sec
 - rampa di decelerazione: 0.5 - 10 sec
 - limite corrente 100%-30% circa
 - Temperatura di lavoro: 0°C / +40°C (allarme sotto zero)
 - Diagnostica tramite LED
 - Frequenza di commutazione: 16kHz
 - Dotata di coperchio
 - Velocità regolabile con potenziometro 5-10 kΩ o con segnale 0-10 Vcc
 - Limitazione della corrente regolabile
 - Sensore termico di protezione
- *Transistor bidirectional drive with regenerative current system.*
 - *Following settings can be adjusted (by built in trimmers):*
 - *acceleration ramp: 0.5 - 10 sec*
 - *deceleration ramp: 0.5 - 10 sec*
 - *current limit 100% - about 30%*
 - *Room temperature: 0°C / +40°C (alarm below zero)*
 - *LED for system diagnosis*
 - *Switching frequency: 16kHz*
 - *Covered*
 - *5-10 kΩ Speed pot. or 0-10 Vdc external signal for speed regulation*
 - *Variable current limit*
 - *Thermal sensor for protection*

Modello <i>Model number</i>	Tensione di alimentazione <i>DC input voltage</i> [Vdc]	Tensione di uscita <i>Motor voltage</i> [Vdc]*	Corrente di uscita nominale <i>DC load current</i> [A]	Corrente di picco motore <i>Maximum load current</i> [A]**	Campo di alimentazione <i>Power supply range</i> [Vdc]
PLN20	12 ÷ 24	0 ÷ Vin	20	60 (4 sec)	10 ÷ 30
PLN40	12 ÷ 24	0 ÷ Vin	40	120 (1 sec)	10 ÷ 30

* L'azionamento riduce la tensione nominale di 1-2 Vcc. Il fenomeno è normale e fisiologico. Se serve ottenere 24 ÷ 12 Vcc in uscita sotto ogni condizione di carico, si suggerisce di sovralimentare di un paio di volt.

** Un timer impone il limite con un andamento temporale iperbolico, cioè quanta più corrente eroga e tanto meno è il tempo per il quale ciò è ammesso, prima che appunto la scheda vada in limitazione. Alla corrente di picco (x 3 volte quella nominale) la scheda funziona per pochi secondi.

* *The drive reduces the rated voltage of 1-2 Vdc. This is normal and physiological. If 24 ÷ 12 VDC output is required under all load conditions, it is advisable to supercharge a couple of volts.*

** *A timer imposes a limit with a temporary hyperbolic performance, which means the more current is requested, the less time is permitted with this current before the drive is limited. When the current reaches its peak (3 times the rated value) the drive will work for a few seconds.*

Dotazioni

Equipment

	PLN20 PLN40
Trimmer di selezione ACCEL, DECEL e LIMITE di CORRENTE / <i>Selection Trimmer ACCEL, DECEL, CURRENT LIMIT</i>	■
2 contatti: marcia avanti e marcia indietro / <i>2 contacts : forward and reverse</i>	■
Riferimento di velocità / <i>Speed setpoint reference</i>	■
3 LEDs di segnalazione / <i>3 LEDs signals</i>	■
Segnale di comando di eventuale freno negativo di stazionamento / <i>Command signal for possible negative electromagnetic brake</i>	■
Predisposizione per montaggio a libro e a zoccolo / <i>Arranged for 2 different ways of mounting</i>	■
Memorizzazione e segnalazione degli allarmi / <i>Memory storage and report of allarm</i>	■
2 ingressi digitali ausiliari / <i>2 auxiliary digital inputs</i>	■#
1 relè segnalazioni allarmi / <i>Alarm output relays</i>	■
# uno impegnato dal reset / <i>one comitted by reset</i>	



PLN20/40

**AZIONAMENTO BIDIREZIONALE PWM
PER MOTORI CC**

**BIDIRECTIONAL PWM CONTROL
FOR DC MOTORS**

Dimensioni

Dimensions

PLN20

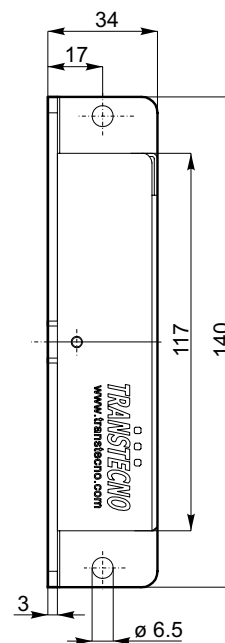
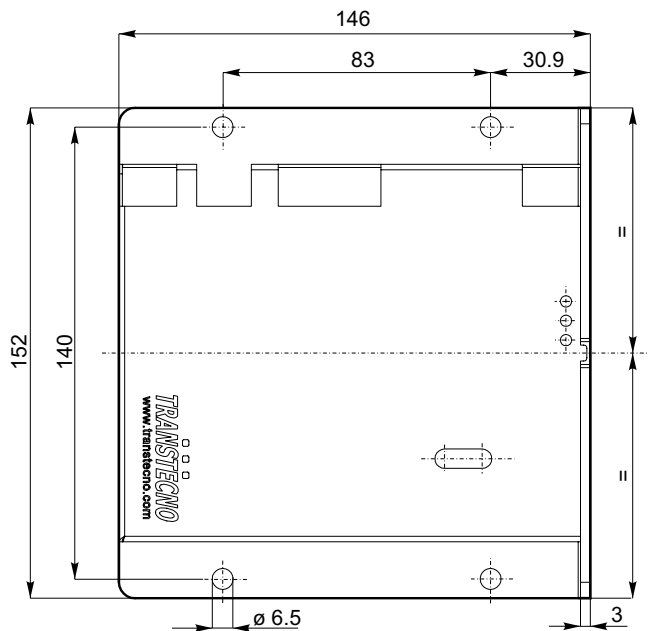

PLN40

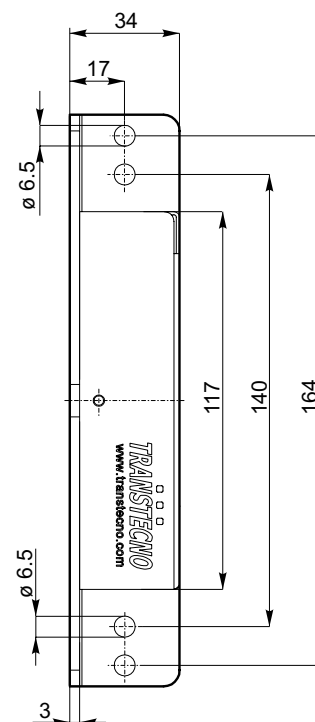
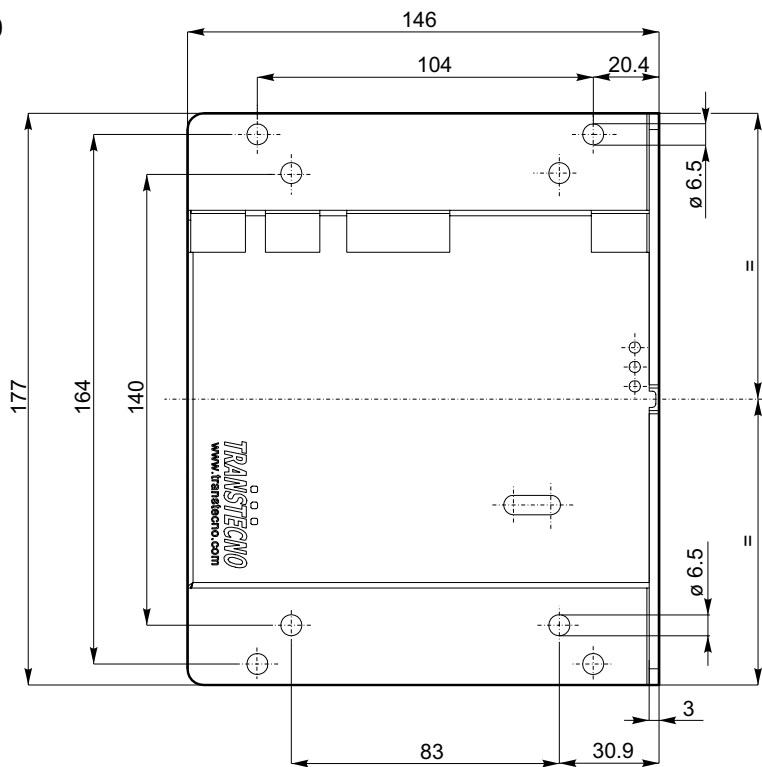



PLN20/40

**AZIONAMENTO BIDIREZIONALE PWM
PER MOTORI CC**

**BIDIRECTIONAL PWM CONTROL
FOR DC MOTORS**

SCHEMA DEI COLLEGAMENTI - MAIN CONNECTION DIAGRAM

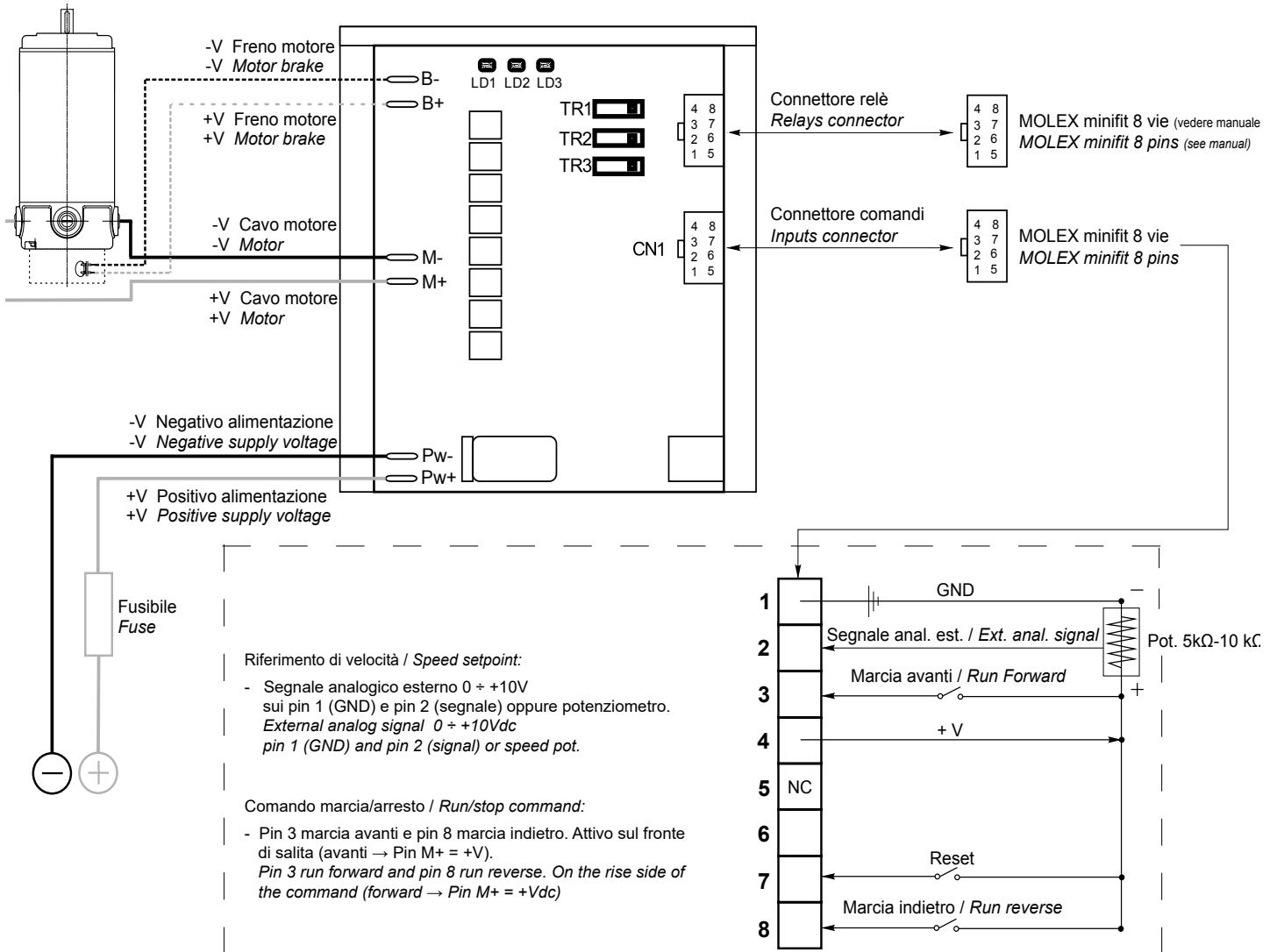

Fusibile:

150-200% della corrente motore. Max 3 volte la corrente nominale della scheda, con intervento entro pochi secondi.

Fuse:

150-200 % rated motor current. Max 3 times rated current of the drive (trip time in few seconds).

Trimmer multigiro:

TR1: Accelerazione: selezione da 0.5 a 10 sec.

TR2: Limite di corrente: riduce il limite di corrente nominale da 100% a circa 30% (corrente di picco 3 volte la corrente selezionata).

TR3: Decelerazione: selezione da 0.5 a 10 sec.

Multiturn trimmers:

TR1: Acceleration time: from 0.5 to 10 sec.

TR2: Current limitation: rated current limited from 100% to about 30% (peak current 3 times the selected limited current).

TR3: Deceleration time: from 0.5 to 10 sec.

LED:

LD1: Visualizza lo stato di funzionamento con limite di corrente attivo (il motore assorbe più della corrente selezionata e l'azionamento opera in limitazione).

LD2: Stato dell'azionamento: lampeggio veloce e continuo = funzionamento normale, lampeggio lento e codificato = presenza di un allarme

LD3: Segnalazione presenza alimentazione.

LED:

LD1: ON when the drive runs under current limitation (motor requires more than the rated current and drive supplies only limited current).

LD2: Status: quick continuous flash = drive ok, slow coded flash = fault).

LD3: Power ON



BLD07-IT

AZIONAMENTO 4Q PER MOTORI BRUSHLESS

DRIVE 4Q FOR BRUSHLESS MOTORS

L'azionamento BLD07-IT è la nuova e aggiornata versione della precedente BLD07. Realizzato su una nuova PCB, sono state implementate caratteristiche e funzionalità che prima si potevano ottenere solo con drive di potenze superiori.

Il risultato è quello di avere un drive più versatile e all'avanguardia, che può essere customizzato, oppure comandato via bus di campo (CAN Open opzionale).

The BLD07-IT drive is the new and updated version of the previous BLD07. Built on a new PCB, features and functionality have been implemented, where previously could only be achieved with higher power drive.

The result is to have a more versatile drive and to 'cutting edge, which can be customized, or controlled via the field bus (CAN Open optional).

Caratteristiche standard

Standard features

- | | |
|--|---|
| <ul style="list-style-type: none"> ● Azionamento bidirezionale rigenerativo ● Alimentazione singola CC ● 3 Leds per la diagnostica (stato ed allarmi) ● Protetto per corto circuito, min/max tensione, mancanza celle di Hall ● Protezione termica motore Ixt ● Connettori estraibili (segnali e potenza) ● Comando di velocità analogico 0 +10Vcc e PWM ● 4 Ingressi digitali – optoisolati ● 2 Uscite NPN - allarmi e frequenza di lavoro ● Regolazione rampa di accelerazione | <ul style="list-style-type: none"> ● Bidirectional regenerative operation ● Single supply DC voltage ● 3 diagnostic Leds (State and Alarms) ● Protections for: Over/Under voltage, ● Over current, Hall missing ● Ixt motor current protection ● Power and signals extractable connectors ● Analog speed command 0 + 10Vdc and PWM ● 4 Digital inputs – optoisolated ● 2 NPN - fault drive and running frequency ● Acceleration adjustment |
|--|---|

Dati tecnici principali

Specifications

- | | |
|--|--|
| <ul style="list-style-type: none"> ● Idoneo per motori BLDC trifase 4/8 poli ● Retroazione digitale sensori di Hall ● Frequenza PWM 20 KHz ● Temperatura operativa 0/+40°C ● Ingresso analogico 0/+10Vcc ● Regolazione della velocità ● Rampa accelerazione regolabile 0.1/1sec (tramite dip switch) ● Regolazione corrente max ● Regolazione della velocità (potenziometro esterno o interno) esterno 10KΩ | <ul style="list-style-type: none"> ● Suitable for 3ph BLDC motors 4/8 poles ● Digital feedback Hall sensors ● PWM frequency 20 KHz ● Operative temperature 0/+40°C ● Analog inputs range 0/+10Vdc ● Variable speed range ● Acceleration ramp adjustable 0.1/1sec (by dip switch) ● Current max regulation ● Speed change regulation (by external or internal pot) external 10KΩ |
|--|--|

MODELLO / MODEL		BLD07-IT
Tensione nominale motore <i>Motor DC Voltage</i>	(Vdc)	24 - 36
Tensione di alimentazione min / max <i>Supply DC Voltage Range min / max</i>	(Vdc)	20-40
Corrente nominale <i>Rated Current</i>	(A)	7
Corrente di picco (1) <i>Peak Current</i>	(A)	14
Potenza nominale (2) <i>Rated Power</i>	(W)	230
Potenza di picco (3) <i>Peak Power</i>	(W)	460

(1) La corrente di picco viene erogata per un tempo di circa 2 secondi
(1) *Peak current (Adc) for 2 sec.*

(2) La potenza nominale è riferita al valore di tensione e di corrente nominale
(2) *Power of amplifier at the rated current and rated voltage*

(3) La potenza di picco è riferita al valore di tensione nominale e di corrente di picco
(3) *Power of amplifier at the peak current and rated voltage*



BLD07-IT

**AZIONAMENTO 4Q
PER MOTORI BRUSHLESS**

**DRIVE 4Q
FOR BRUSHLESS MOTORS**

Dimensioni

Dimensions

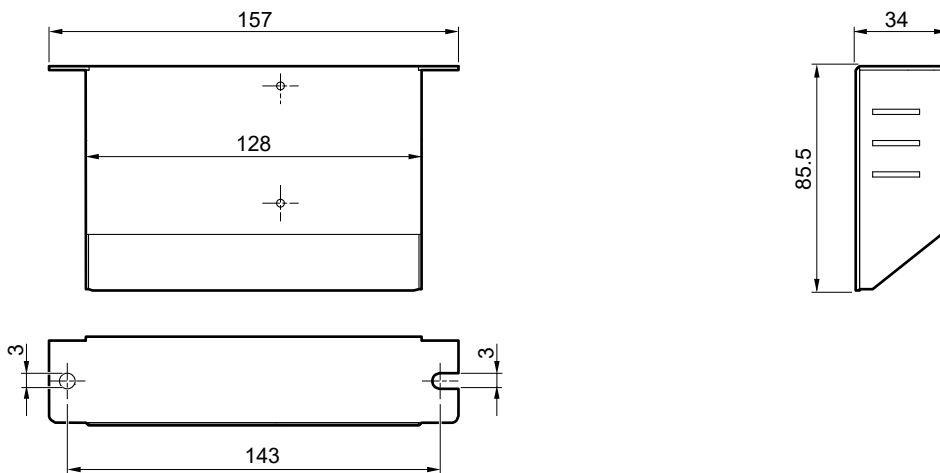

Collegamenti

Connections

L'azionamento BLD07-IT è dotato di:

- connettore estraibile a 5 morsetti per la parte di potenza;
- tre connettori estraibili, per un totale di 16 morsetti, per la gestione dei segnali in ingresso ed in uscita.

The BLD07-IT drive is equipped with:

- removable connector with 5 terminals for the power part;
- 3 removable connectors, for a total of 16 terminals, for the management of the input and output signal.

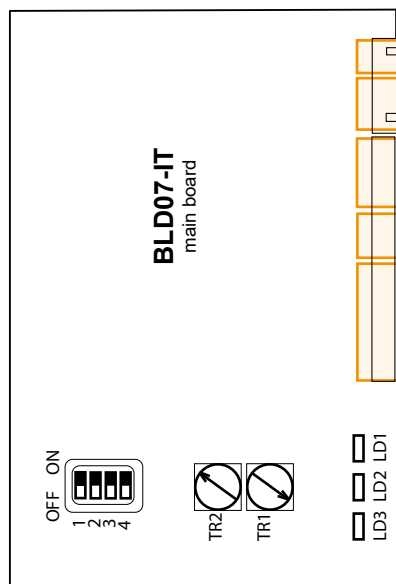

V+	Alimentazione: positivo Vcc	Voltage supply: positive Vdc
GND	Alimentazione: negativo	Voltage supply: negative

U	Motore fase U	Motor phase U
V	Motore fase V	Motor phase V
W	Motore fase W	Motor phase W

H-	Alimentazione sensore Hall (negativo)	Sensor Hall (negative)
HW	Sensore Hall: fase W	Hall sensor phase W
HV	Sensore Hall: fase V	Hall sensor phase V
HU	Sensore Hall: fase U	Hall sensor phase U
H+	Alimentazione sensore Hall (+12V)	Sensor Hall: positive (+12V)

+10V	Potenziometro esterno 10k	External pot. 10k
SIG	Segnale analogico 0/+10V	Analogo Signal 0/+10V
GND		

FREQ	Uscita onda quadra proporzionale alla velocità (NPN open coll.)	Square wave output proportional to the speed (NPN Open coll.)
FAULT	Uscita di allarme (NPN open coll.)	Alarm output (NPN open coll.)
+12V	Sorgente tensione	Voltage source
F/R	Senso di marcia	Selection of the direction
R/S	Avvio/arresto	Start/stop
GND	Comune R/S e F/R	R/S and F/R Common for commands
IN1	Input digitale	Digital input
IN2	Input digitale	Digital input



BLD07-IT

**AZIONAMENTO 4Q
PER MOTORI BRUSHLESS**

**DRIVE 4Q
FOR BRUSHLESS MOTORS**

Collegamenti

Connections

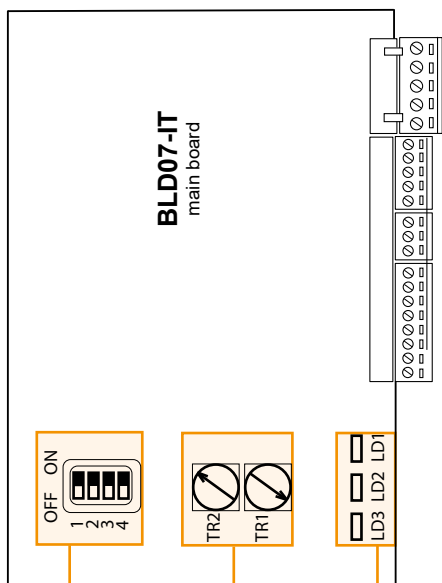

Led		
LD1	Verde - power ON	Green - power ON
LD2	Rosso - allarme in corso	Red - alarm
LD3	Giallo - superamento corrente max.	Yellow - the drive is in limit of current
Presenti 2 Leds per la chiusura dei contatti R/S e F/R		2 LEDs for the closing of R/S and F/R

Trimmer		
TR1	Regolazione velocità (crescente con rotazione oraria)	External speed pot (clockwise to increase)
TR2	Limitazione corrente (crescente con rotazione antioraria)	Current limitation (counter clockwise to increase)

Dip Switch		
1	OFF = Controllo velocità da pot. interno TR1	Internal speed pot TR1
	ON = Controllo velocità da pot. esterno o segnale analogico 0/+10V	External speed pot or analog signal 0/+10V
2	OFF = Funzionamento in anello chiuso	Operating in closed loop
	ON = Funzionamento in anello aperto	Operating in open loop
3	OFF = Rampe rapide (0.1 s)	Fast Acceleration (about 0.1 sec)
	ON = Rampe lente (1.0 s)	Slow acceleration (about 1.0 sec)
4	OFF = per motori a 4 poli	4 poles motors
	ON = per motori a 8 poli	8 poles motors



BLD10

AZIONAMENTO 4Q PER MOTORI BRUSHLESS

4Q DRIVE FOR BRUSHLESS MOTORS

Caratteristiche standard

Standard characteristic

- Azionamento quattro quadranti rigenerativo
- Alimentazione singola DC
- 5 Leds per la diagnostica (stato ed allarmi)
- Protetto per corto circuito, min/max tensione, sovratemperatura, mancanza celle di hall
- Protezione termica motore Ixt
- Connettori estraibili 16 vie (segnali) e 5 vie (potenza)
- 1 Comando di velocità differenziale analogico +/-10V
- 1 Comando di coppia analogico +/-10V per realizzare avvitatori, svolgitori, macchine test, ecc
- Feedback da sensori di Hall ed encoder (selezionabile)
- 1 Uscita NPN segnalazione allarme azionamento
- 4 trimmers di regolazione e rampa di accelerazione/dec.

- *Four quadrant regenerative operation*
- *Single supply DC voltage*
- *5 diagnostic Leds (State and Alarms)*
- *Protections for: Over/Under voltage, max. temperature, Over current, hall missing*
- *Ixt motor current protection*
- *Power and signals extractable connectors*
- *1 Differential velocity input +/-10V*
- *1 Torque mode (demand current) input +/-10V*
- *Feedback by Hall sensors (series), or encoder (selectable)*
- *NPN Fault drive output*
- *Four potentiometer adjustments (Speed, offset, gain, derivative)*

Dati tecnici principali

Specifications

- Tensione d'uscita massima 0,9 Vcc ingresso
- Frequenza PWM 20Khz
- Temperatura operativa 0/+45°C
- Ingressi analogici +/-10Vdc
- Monitor di corrente +/- 8Vdc=I di picco
- Monitor di velocità (T.P) +/- 8Vdc=max.vel
- Alimentazioni d'uscita ausiliarie +/-10Vdc @ 4mA
- Segnale (Start) di abilitazione +9V/+30Vdc max
- Banda passante (anello corrente) 2KHz
- Banda passante (anello di vel.) 150Hz
- Induttanza minima motore 400uH
- Grado inquinamento 2° o migliore

- *Output voltage 0,9 Vdc Input*
- *PWM frequency 20Khz*
- *Operative temperature 0/+45°C*
- *Analog inputs range +/-10Vdc*
- *Current monitor +/- 8Vdc (At peak curr.)*
- *Velocity monitor +/- 8Vdc (At max.vel.)*
- *Ausiliary power supply +/-10Vdc @ 4mA*
- *Start signal (Input range) +9V/+30Vdc*
- *Current loop bandwidth 2KHz*
- *Velocity loop bandwidth 150Hz*
- *Minimum motor inductance 400uH*
- *Polution degree 2° or better*

MODELLO / MODEL		BLD10
Tensione nominale motore <i>Motor DC Voltage</i>	(V)	24 - 36 - 48
Tensione di alimentazione min / max <i>Supply DC Voltage Range min / max</i>	(V)	20-84
Corrente nominale <i>Rated Current</i>	(A)	10
Corrente di picco (1) <i>Peak Current</i>	(A)	20
Potenza nominale (2) <i>Rated Power</i>	(W)	580
Potenza di picco (3) <i>Peak Power</i>	(W)	1060

(1) La corrente di picco viene erogata per un tempo di circa 2 secondi
(1) *Peak current (A_{dc}) for 2 sec.*

(2) La potenza nominale è riferita al valore di tensione e di corrente nominale
(2) *Power of amplifier at the rated current and rated voltage*

(3) La potenza di picco è riferita al valore di tensione nominale e di corrente di picco
(3) *Power of amplifier at the peak current and rated voltage*



BLD10

**AZIONAMENTO 4Q
PER MOTORI BRUSHLESS**

**4Q DRIVE
FOR BRUSHLESS MOTORS**

Dimensioni

Dimensions

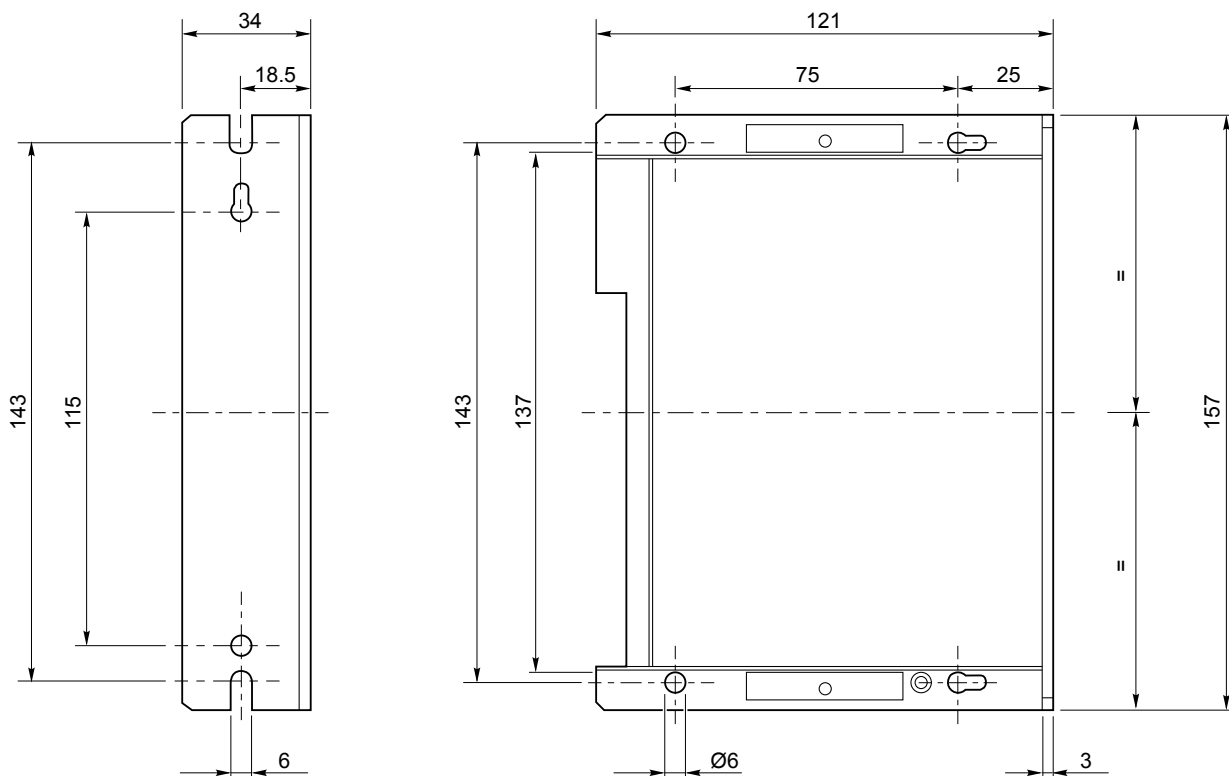

Collegamenti

Connections

L'azionamento viene fornito adeguatamente tarato per la maggior parte dei motori brushless serie BL presenti a catalogo. Vengono fornite in dotazione alcune resistenze per eventuali tarature diverse.

The drive is calibrated adequately for most of the brushless motors BL series in the catalogue. For different motor setting some resistances are supplied in the box.

Il settaggio standard non prevede la presenza di rampe di accelerazione e decelerazione, ma è possibile introdurle modificando la taratura interna. Il campo di taratura possibile è: 0.1-10 secondi circa

The standard set up does not include acceleration and deceleration ramps, however it is possible to introduce them by changing the internal set up. The set up range available is: 0.1-10 seconds approximately.

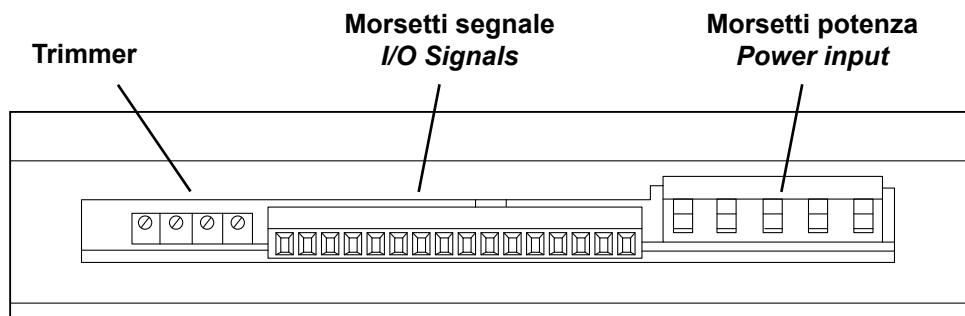



BLD10

AZIONAMENTO 4Q PER MOTORI BRUSHLESS

4Q DRIVE FOR BRUSHLESS MOTORS

Collegamenti per motori brushless serie BL

Connections for brushless motors BL series

Fili di potenza:

- Giallo grosso (oppure blue) -fase motore U: pin U
- Rosso grosso (oppure marrone) - fase motore V: pin V
- Nero grosso - fase motore W: pin W

Fili di segnale:

- Rosso piccolo (+Vcc): pin 12
- Nero piccolo (GND): pin 13
- Blue (hall U): pin 14
- Verde (hall V): pin 15
- Bianco (hall W): pin 16

Power wires:

- Yellow big (or blue) - phase motor U: pin U
- Red big (or brown) - phase motor V: pin V
- Black big - phase motor W: pin W

Fili di segnale:

- Red small (+Vdc): pin 12
- Black small (GND): pin 13
- Blue (hall U): pin 14
- Green (hall V): pin 15
- White (hall W): pin 16

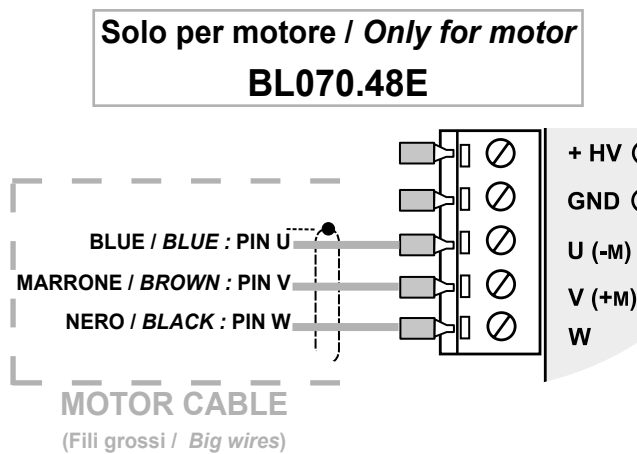
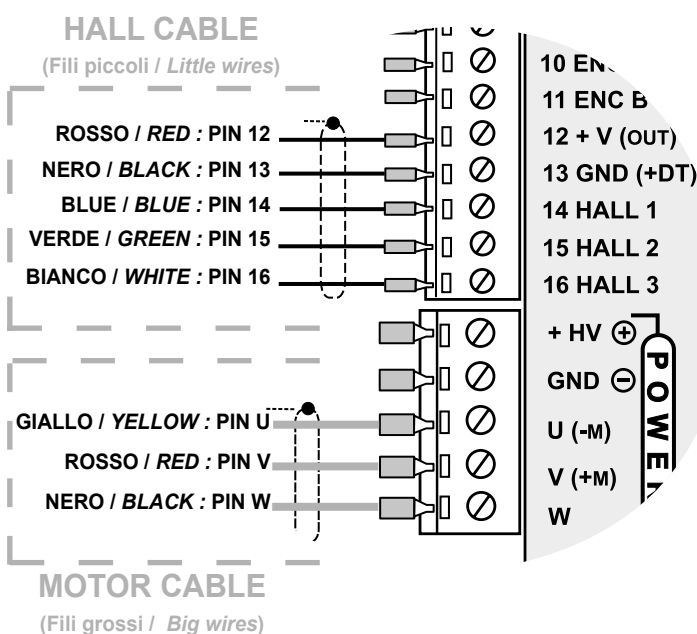
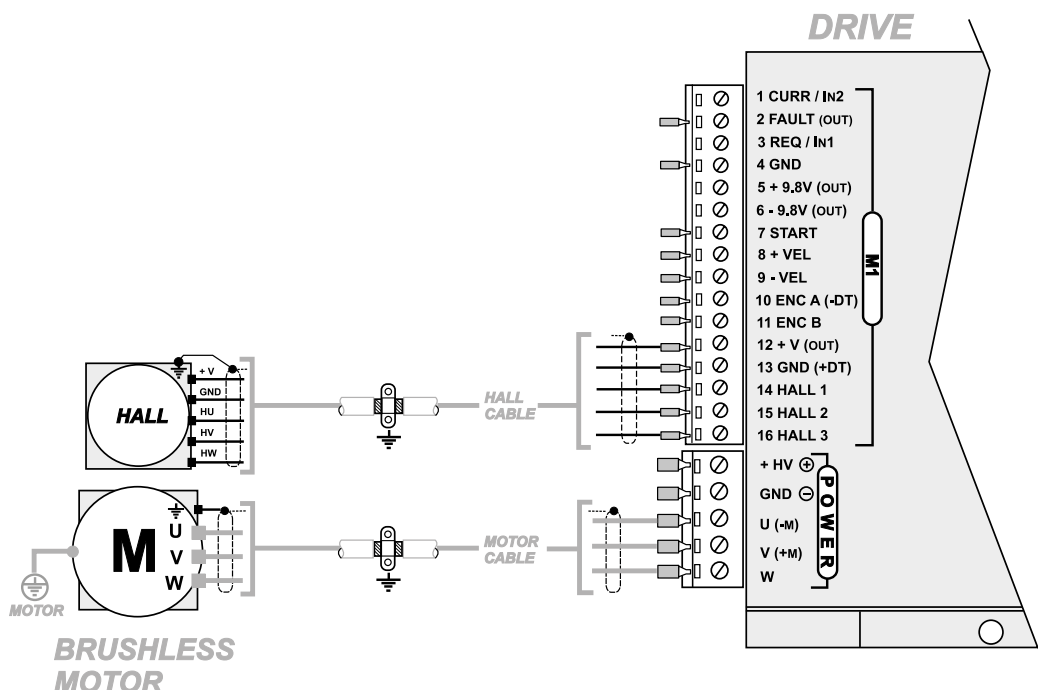

Per il solo motore BL070.48E, la colorazione dei cavi di potenza differisce, mentre la colorazione dei cavi di segnale rimane la stessa degli altri motori

On BL070.48E motor the power wire color is different. The signal wires color is the same as the other motors.



BLD10

**AZIONAMENTO 4Q
PER MOTORI BRUSHLESS**

**4Q DRIVE
FOR BRUSHLESS MOTORS**

Collegamenti con altri componenti

Connections with other devices

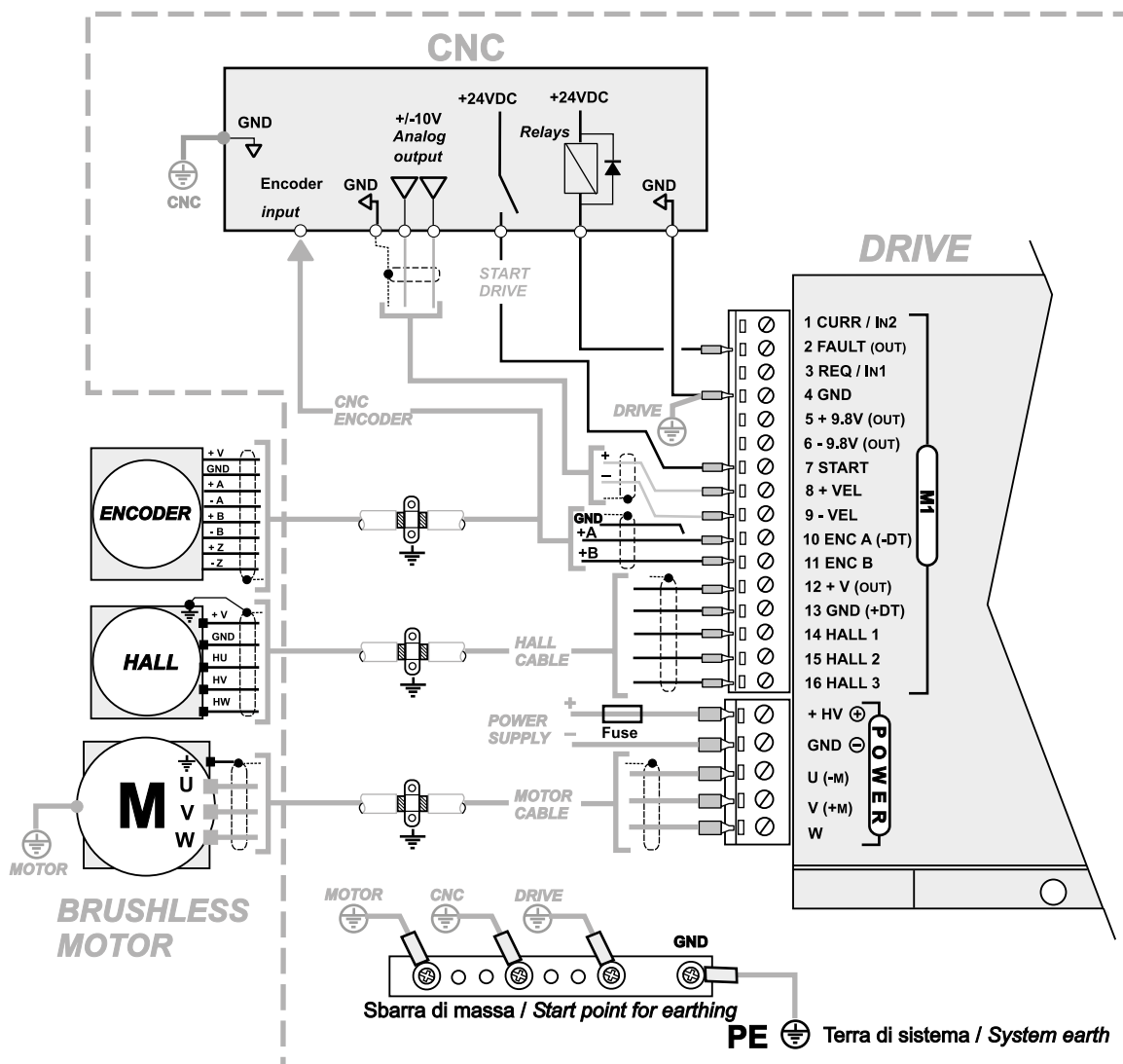



**ELETTRONICA INTEGRATA
PER MOTORI BRUSHLESS
VERSIONE IE**

**INTEGRATED ELECTRIC CONTROL
FOR BRUSHLESS MOTORS
IE VERSION**

Collegamenti per motori Brushless

Brushless motor connection

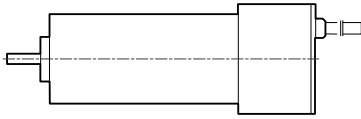

BL005.240-IE

Cavi di collegamento

Rosso = tensione positiva (+24 Vcc)

Blu = tensione negativa

Bianco = potenziometro
(da 1 a 3.5 Vdc oltre il negativo)

Verde = senso di marcia

BL005.240-IE

Leads connection reference

Red = positive voltage supply (+24 Vdc)

Blue = negative voltage supply

*White = speed reference voltage
(from 1 to 3.5 Vdc over the negative)*

Green = selection of direction

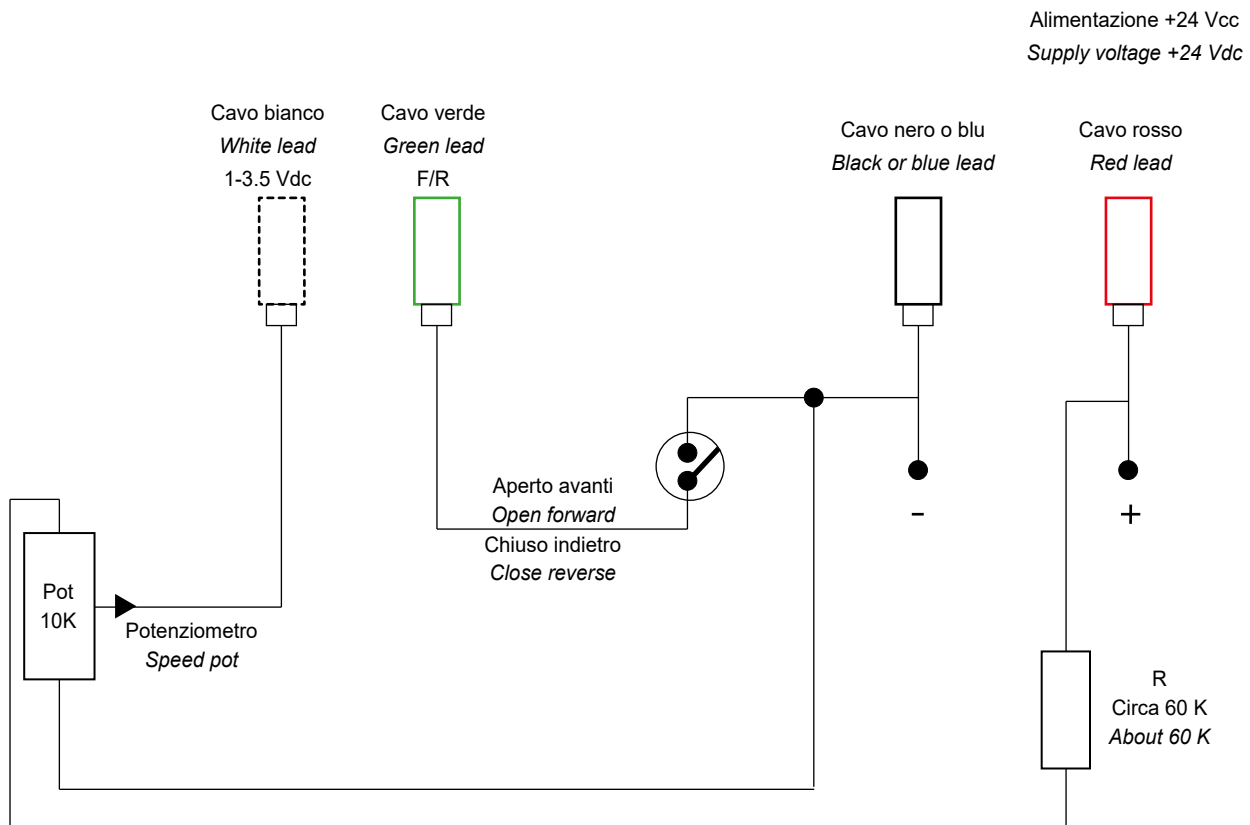



ELETTRONICA INTEGRATA
PER MOTORI BRUSHLESS
VERSIONE IE

INTEGRATED ELECTRIC CONTROL
FOR BRUSHLESS MOTORS
IE VERSION

Collegamenti per motori Brushless

Brushless motor connection

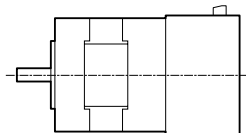

BL012.240-IE e BL018.240-IE

BL012.240-IE and BL018.240-IE

+5v	F/R	SV	PG	GND	-VP	+VP
1	2	3	4	5	6	7

7 +VP	Tensione positiva +24Vcc / DC power input +24Vdc
6 -VP	Tensione negativa di alimentazione / Power ground
5 GND	Riferimento comune per i segnali / Common ground of system
4 PG	Impulsi per giro (24) / Speed pulse output (TTL), 24 pulse/rev
3 SV	Potenziometro / Speed voltage 0-5 VDC
2 F/R	Senso di marcia / Rotating direction. Hi=CW
1 +5V	Tensione 5 Vcc in uscita / +5V voltage output

Per gli altri dati riferirsi al motore standard / For all other data, see the standard motor.

BL032.240-IE e BL043.240-IE

BL032.240-IE and BL043.240-IE

+5v	F/R	SV	PG	GND	-VP	+VP
1	2	3	4	5	6	7

7 +VP	Tensione positiva +24Vcc/+36Vcc / DC power input +24Vdc/+36Vdc
6 -VP	Tensione negativa di alimentazione / Power ground
5 GND	Riferimento comune per i segnali / Common ground of system
4 PG	Impulsi per giro (12) / Speed pulse output (TTL), 12 pulse/rev
3 SV	Potenziometro / Speed voltage 0-5 VDC
2 F/R	Senso di marcia / Rotating direction. Hi=CW
1 +5V	Tensione 5 Vcc in uscita / +5V voltage output

Per gli altri dati riferirsi al motore standard / For all other data, see the standard motor.

Drivers

SCHEMA 1 / DIAGRAM 1

SCHEMA 2 / DIAGRAM 2

Alimentazione +24 Vcc
Supply voltage +24 Vdc

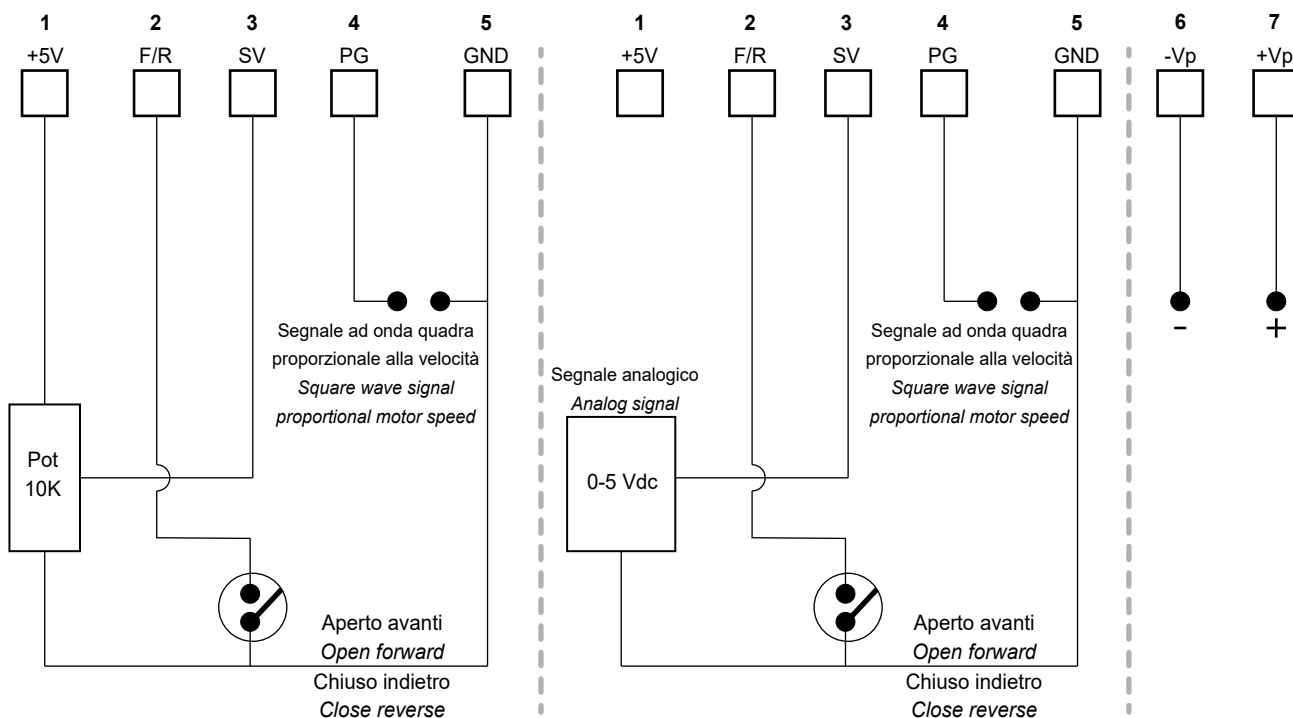

Micro encoder ME22
ME22 Micro encoder



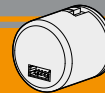

	Pag. Page
Indice	
Descrizione	12
Caratteristiche principali	12
Designazione	12
Specifiche di funzionamento	13
Dimensioni	14
Schema di connessione	14
Index	
<i>Description</i>	12
<i>Technical features</i>	12
<i>Classification</i>	12
<i>Operating conditions</i>	13
<i>Dimensions</i>	14
<i>Connection diagram</i>	14

Questa sezione annulla e sostituisce ogni precedente edizione o revisione. Qualora questa sezione non Vi sia giunta in distribuzione controllata, l'aggiornamento dei dati ivi contenuto non è assicurato. **In tal caso la versione più aggiornata è disponibile sul nostro sito internet www.micro-intecno.com**

*This section replaces any previous edition and revision. If you obtained this catalogue other than through controlled distribution channels, the most up to date content is not guaranteed. **In this case the latest version is available on our web site www.micro-intecno.com***

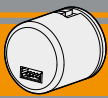

Descrizione

ME22 è un encoder ottico ad albero cavo, affidabile ed economico, che può essere fissato rapidamente e con facilità ad alberi motore di diverse taglie.

L'encoder offre due uscite ad onda quadra in quadratura (sfasate di 90 gradi), per conteggio e direzione. La risoluzione dell'encoder è determinata dal numero di conteggi per rotazione (CPR). Alimentazione e segnali sono forniti da un connettore Molex a 5 pin.

Description

The ME22 is a reliable low cost optical hollow shaft encoder that can be fixed quickly and easily on different sizes of motor shafts. The encoder provides two square wave outputs in quadrature (90 degrees phase shifted) for counting and direction information. The revolution of the encoder is determined by the number of counts per revolution (CPR). Power supply and signals are provided by a 5 pin Molex connector.

Caratteristiche principali

- Dimensioni compatte: 22,0 mm (diametro) x 21,9 mm (lunghezza)
- Montaggio rapido e semplice, senza venire a contatto con componenti sensibili
- Canali di uscita: 2 (in quadratura) + 1 canale di zero opzionale
- Tensione d'alimentazione: 5 Vcc.
- Tipo di uscita: TTL compatibile.
- Circuito di uscita: pull up
- Risoluzione: fino a 360 CPR (Conteggi Per Rotazione).
- Diametro albero max.: 9,525 mm (3/8")
- Temperatura di funzionamento: da -20 °C a +85 °C.
- Frequenza: 60 kHz.
- Conforme alla direttiva UE 2002/95/CE (RoHS)

Technical features

- Small size: 22.0 mm (diameter) x 21.9 mm (length)
- Quick and easy assembly without touching sensitive components
- Output channels: 2 (quadrature) + 1 optional index
- Power supply: 5 VDC
- Output type: TTL compatible.
- Output circuit: pull-up
- Resolution up to 360 CPR (counts per revolution)
- Maximum shaft diameter: 9.525 mm (3/8")
- Operating temperature: -20 °C to +85 °C
- Frequency: 60 kHz
- Compliant EU-directive 2002/95/EG (RoHS)

Designazione

Classification

ME22	100	6.000	2	LS
Risoluzione Encoder (CPR) Encoder Resolution (CPR)	Diametro Albero Motore (mm) Motor shaft diameter (mm)	Numero di canali Number of channels	Opzioni uscita Output option	
001 **	1.500	1 = 1 Canale 1 = 1 Channel	LS = Connettore + cavo standard Connector + standard cable	
002 **	2.000	2 = 2 Canali 2 = 2 Channels		
004 **	2.300			
008 **	2.500			
050 ***	3.000			
064 ***	3.175 (1/8")			
100	3.969 (5/32")			
108	4.000			
120	4.763 (3/16")			
124	5.000			
128	6.000			
150	6.350 (1/4")			
160	8.000			
200	9.000			
250	9.525 (3/8")			
256				
300				
360				

** : solo due canali
** : only two channels

*** : un solo canale
*** : only 1 channel

 Codici preferenziali
Preferred code

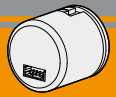

Specifiche di funzionamento

Operating conditions

Le specifiche elettriche sono valide solo quando l'encoder opera nell'intervallo di temperatura di funzionamento.
Le misure sono riferite alla temperatura di 25 °C, con alimentazione $V_{cc} = 5 V \pm 5\%$.

Electrical characteristics are only effective for the range of the operating temperatures.
Typical values at 25°C and $V_{dc} = 5 V$

Parametri Parameters	Simbolo Symbols	Nominale Rated	Min. Min.	Max. Max.	Unità Unit	Note Notes
Temperatura di funzionamento <i>Operating Temperature</i>	T_A	+25	- 20	+85	° C	
Tensione di alimentazione <i>Supply voltage</i>	V_{CC}	5.0	4.5	5.5	V_{DC}	
Corrente di alimentazione (due canali) <i>Supply current (two channels)</i>	I_{CC}	15	13	18	mA	
Capacità di linea (valore ammissibile) <i>Load capacitance</i>	C_L			100	pF	internal pull-up 2.7 kΩ
Frequenza di conteggio <i>Output frequency</i>	f			60	kHz	$\text{rpm} \times N / 60 \times 10^{-3}$
Tensione di uscita livello alto (versione standard) <i>High level output voltage (standard)</i>	V_{OH}		2.4	V_{CC}	V_{DC}	$I_{OH} = -0.2 \text{ mA}$
Tensione di uscita livello basso (versione standard) <i>Low level output voltage (standard)</i>	V_{OL}			0.4	V_{DC}	$I_{OL} = 8 \text{ mA}$
Tempo di salita (versione standard) <i>Rise time (standard)</i>	T_r	500/(7)*			ns /(μs)*	$C_L = 25 \text{ pF}$
Tempo di discesa (versioni standard) <i>Fall time (standard)</i>	T_f	100/(1.3)*			ns /(μs)*	$R_L = 2.7 \text{ k}\Omega$

* solo per 1, 2, 4, 8 CPR

* only for 1, 2, 4, 8 CPR

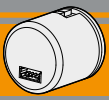

Micro encoder ME22

ME22 Micro encoder

Dimensioni e schema di connessione

Dimensions and connection diagram

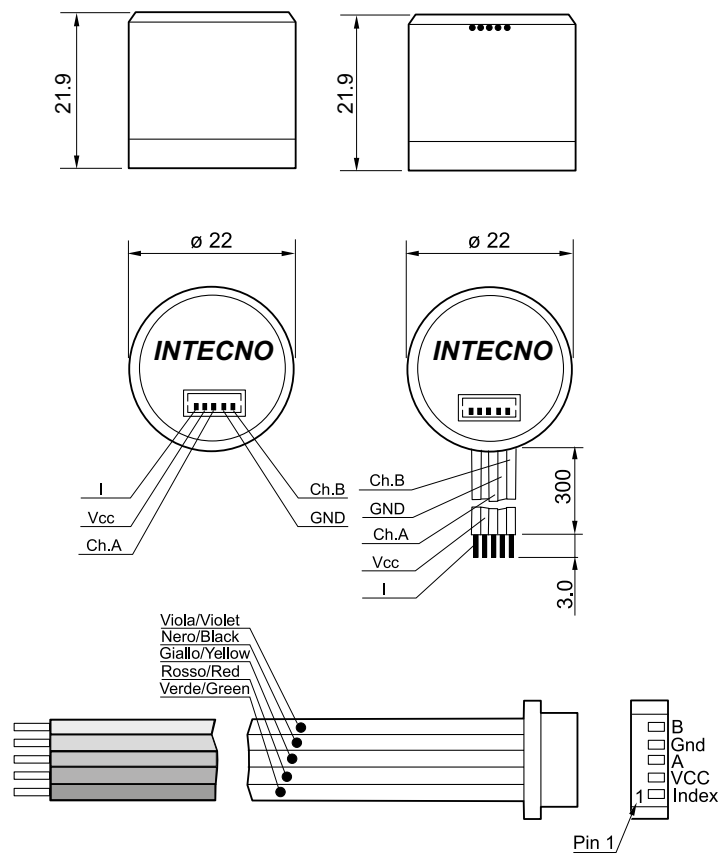

**INTECNO SRL**

Via Caduti di Sabbiuno, 9/E
 40011 Anzola dell'Emilia (BO) - ITALY
 Tel: +39 051 19985350
 Fax: +39 051 19985361
 info@intecno-srl.com
 www.intecno-srl.com



 **MA TRANSTECNO S.A.P.I. DE C.V.**
 Av. Mundial # 176, Parque Industrial
 JM Apodaca, Nuevo León,
 C.P. 66600 - MEXICO
 Tel: +52 8113340920
 info@transtecno.com.mx
 www.transtecno.com.mx

 **TRANSTECNO IBÉRICA**
THE MODULAR GEARMOTOR, S.A.
 C/Enginy, 2 Nave 6 - 08850 Gavà (Barcelona) - SPAIN
 Tel: +34 931 598 950
 info@transtecno.es
 www.transtecno.es

 **SALES OFFICE INDIA**
 A/10, Anagha, S.N. Road, Mulund (W) Mumbai
 400080 - INDIA
 Tel: +91 9820614698
 Fax - Italy: +39 051 734943
 indiaoffice@transtecno.com

 **TRANSTECNO U.S.A. LLC**
 5440 S.W. 156th Place Miami,
 FL 33185 - USA
 Tel: +1 (305) 220-4423
 Fax: +1 (305) 220-5945
 usaoffice@transtecno.com

 **TRANSTECNO B.V.**
 De Stuwdam, 43 - Ind. Terrein Wieken/Vinkenhoef
 3815 KM Amersfoort - NETHERLANDS
 Tel: +31(0) 33 45 19 505
 Fax: +31(0) 33 45 19 506
 info@transtecno.nl
 www.transtecno.nl

 **SALES OFFICE SOUTH KOREA**
 D-304 Songdo BRC Smart Valley 30, Songdomirae-ro,
 Yeonsu-gu, Incheon, 406-840 - KOREA
 Tel: +82 70 8288 2107
 Fax: +82 32 815 2107
 Mobile: +82 10 5094 2107
 koreaoffice@transtecno.com

 **SALES OFFICE BRAZIL**
 Rua Dr. Freire Alemão 155 / 402 - CEP. 90450-060
 Auxiliadora Porto Alegre RS - BRAZIL
 Tel: +55 51 3251 5447
 Fax: +55 51 3251 5447
 Mobile: +55 51 811 45 962
 braziloffice@transtecno.com
 www.transtecno.com.br

 **SALES OFFICE FRANCE**
 12 Impasse des Mûriers
 38300 Ruy - FRANCE
 Tel: +33 (0) 6 85 12 09 87
 Fax - Italy: +39 051 734943
 franceoffice@transtecno.com
 www.transtecno.fr

 **SALES OFFICE OCEANIA**
 44 Northview drive, Sunshine west 3020
 Victoria - AUSTRALIA
 Ph +61 03 9312 4722
 Fax +61 03 9312 4714
 Mobile: +61 0438060997
 oceaniaoffice@transtecno.com
 www.transtecno.com.au

INTECNO member of
TRANSTECNO
 group
 power transmissions

www.micro-intecno.com
 www.intecno-srl.com