



Ferrite

Motoriduttori CC pendolari  
**DC helical parallel gearmotors**





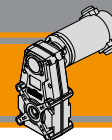

<b>Indice</b>	<b>Index</b>	Pag. Page
Caratteristiche tecniche	<i>Technical features</i>	<b>N2</b>
Designazione	<i>Classification</i>	<b>N2</b>
Sensi di rotazione	<i>Direction of rotation</i>	<b>N3</b>
Simbologia	<i>Symbols</i>	<b>N3</b>
Lubrificazione	<i>Lubrication</i>	<b>N3</b>
Carichi radiali	<i>Radial loads</i>	<b>N4</b>
Dati tecnici	<i>Technical data</i>	<b>N5</b>
Motori applicabili	<i>Motor adapters</i>	<b>N6</b>
Dimensioni	<i>Dimensions</i>	<b>N7</b>

Questa sezione annulla e sostituisce ogni precedente edizione o revisione. Qualora questa sezione non Vi sia giunta in distribuzione controllata, l'aggiornamento dei dati ivi contenuto non è assicurato. **In tal caso la versione più aggiornata è disponibile sul nostro sito internet [www.transtecno.com](http://www.transtecno.com)**

*This section replaces any previous edition and revision. If you obtained this catalogue other than through controlled distribution channels, the most up to date content is not guaranteed. In this case the latest version is available on our web site [www.transtecno.com](http://www.transtecno.com)*

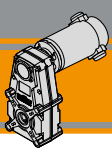

## Caratteristiche tecniche

## Technical features

I motoriduttori CC pendolari a magneti permanenti in ferrite ECFT hanno le seguenti caratteristiche principali:

ECFT ferrite permanent magnets DC helical parallel gearmotors range has the following main features:

- Alimentazione in bassa tensione 12/24 Vcc
- Possibilità di montaggio encoder e freno
- Potenze motore disponibili da 100 a 800W S2
- Magneti in ferrite
- Carcasa pressofusione di alluminio
- Lubrificazione permanente con olio sintetico.
- Ingranaggi cilindrici a denti elicoidali.

- Low voltage power supply 12/24 Vdc
- Suitable for encoder and brake assembly
- Motor power ratings available from 100 to 800W S2
- Ferrite magnets
- Die-cast aluminum housings
- Permanent synthetic oil long-life lubrication.
- helical gears.

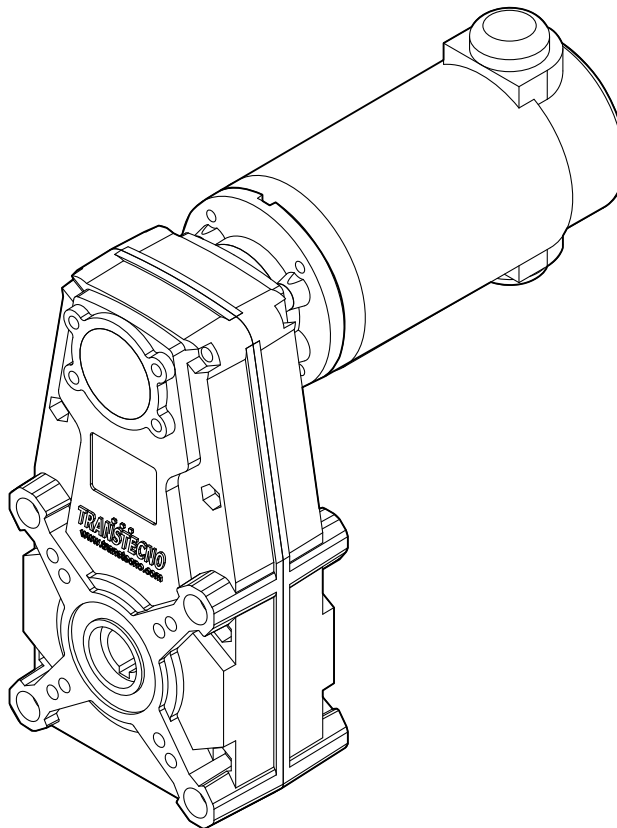

## Designazione

## Classification

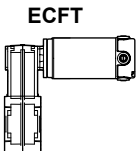
MOTORIDUTTORE / GEARMOTORS										
ECFT	180/146						U	60.63	O20	B5
Tipo Type	Grandezza Size						Versione Version	Rapporto Ratio	Albero cavo uscita Hollow output shaft	Versione motore Motor version
	070/105/3	100/105/3	180/105/3	250/146	350/146	600/146	U...	vedi tabelle see tables	vedi tabelle see tables	120 240 12E 24E
	070/105/4	100/146	180/146	250/196	350/196	600/196				
	070/146									

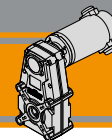

Sensi di rotazione

Direction of rotation

FT105/3  
FT146  
FT196

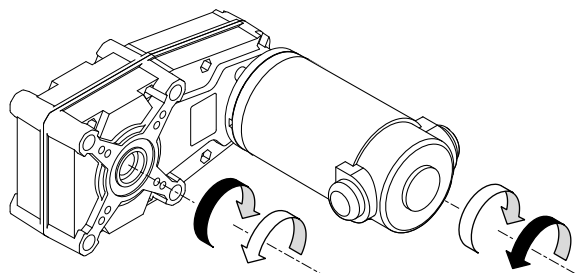
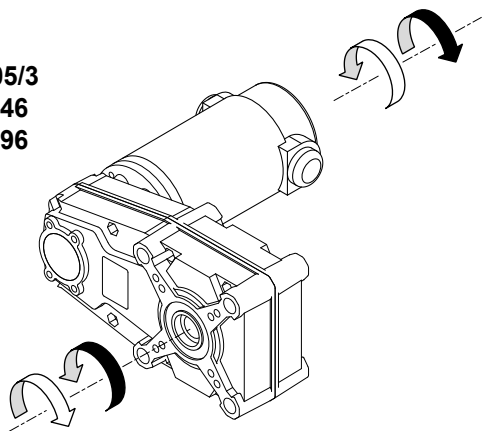

FT105/4

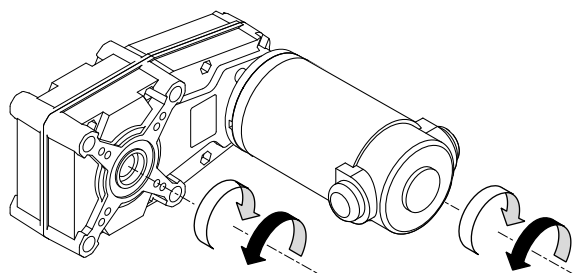
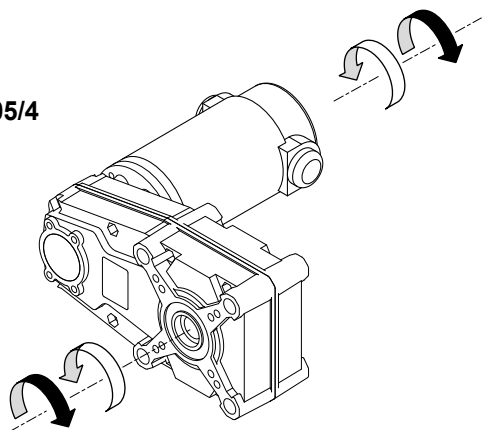

Simbologia

Symbols

$n_1$	[ $\text{min}^{-1}$ ]	Velocità in ingresso / <i>Input speed</i>
$n_2$	[ $\text{min}^{-1}$ ]	Velocità in uscita / <i>Output speed</i>
$i$		Rapporto di riduzione / <i>Ratio</i>
$P_1$	[kW]	Potenza in entrata / <i>Input power</i>
$M_2$	[Nm]	Coppia nominale in uscita in funzione di $P_1$ / <i>Output torque referred to <math>P_1</math></i>
$P_{n1}$	[kW]	Potenza nominale in entrata / <i>Nominal input power</i>
$M_{n2}$	[Nm]	Coppia nominale in uscita in funzione di $P_{n1}$ / <i>Nominal output torque referred to <math>P_{n1}</math></i>
$sf$		Fattore di servizio / <i>Service factor</i>
$R_2$	[N]	Carico radiale ammissibile in uscita / <i>Permitted output radial load</i>
$A_2$	[N]	Carico assiale ammissibile in uscita / <i>Permitted output axial load</i>

Lubrificazione

Lubrication

Tutti i motoriduttori sono forniti completi di lubrificante sintetico viscosità 320, pertanto possono essere installati in qualunque posizione di montaggio e non necessitano di manutenzione.

Permanent synthetic oil long-life lubrication ( viscosity grade 320) makes it possible to use the gearmotors in all mounting positions; for this reason they can be installed in any assembly position and do not require maintenance.

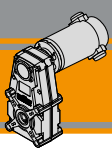

**Carichi radiali**

**Radial loads**

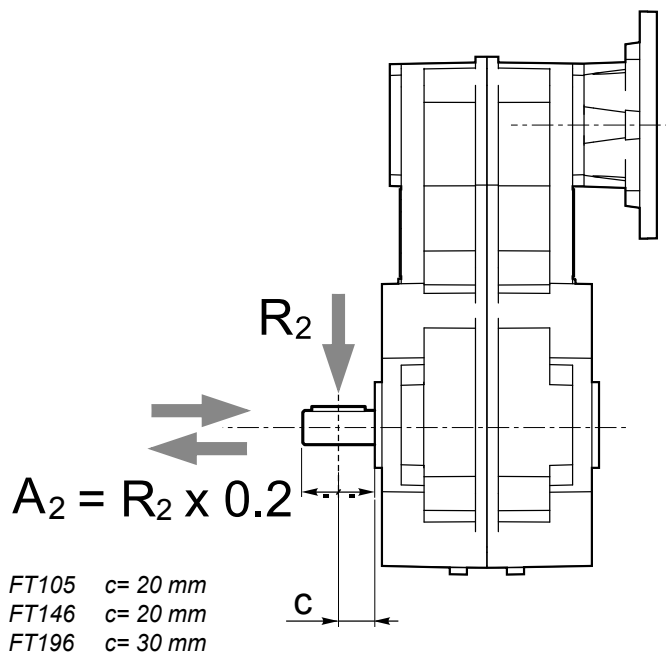

$n_2$ [min <sup>-1</sup> ]	$R_2$ [N]		
	FT105	FT146	FT196
70	1500	2500	3500
40	1700	2700	4000
30	1850	2850	4600
20	2000	3000	5500
10	2000	3000	7000
5	2000	3000	7000

Quando il carico radiale risultante non è applicato sulla mezzera dell'albero occorre calcolare quello effettivo con la seguente formula:

When the resulting radial load is not applied on the centre line of the shaft it is necessary to calculate the effective load with the following formula:

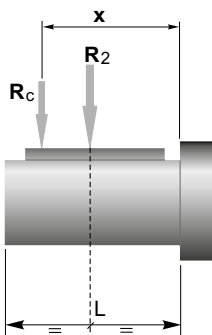

	FT105	FT146	FT196
<b>a</b>	82	82,5	132
<b>b</b>	62	62,5	102
<b>R<sub>2MAX</sub></b>	2000	3000	7000

$$R_c = \frac{R_2 \cdot a}{(b+x)} \leq R_{2MAX}$$

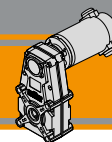

$$R \leq R_c$$

a, b = valori riportati nella tabella  
a, b = values given in the table



Dati tecnici

Technical data

$P_1$ [W]	$n_2$ [min <sup>-1</sup> ]	$M_2$ [Nm]	sf	i		Versione motore Motor version	$P_1$ [W]	$n_2$ [min <sup>-1</sup> ]	$M_2$ [Nm]	sf	i		Versione motore Motor version				
<b>100</b>							<b>140</b>										
(3000 min <sup>-1</sup> )	<b>146</b>	6	5.1	20.57	<b>070/105/3</b>	<b>12E/24E</b>	(3000 min <sup>-1</sup> )	<b>31</b>	40	2.1	95.61	<b>100/146</b>	<b>120/240/24E</b>				
	<b>90</b>	10	3.9	33.32				<b>26</b>	48	1.8	113.40						
	<b>68</b>	13	3.8	44.36				<b>22</b>	56	1.5	133.45						
	<b>55</b>	16	3.1	54.87				<b>20</b>	63	1.4	150.18						
	<b>42</b>	21	2.4	71.84				<b>19</b>	67	1.4	160.43						
	<b>39</b>	23	2.2	77.07				<b>17</b>	75	1.2	178.83						
	<b>34</b>	27	1.9	88.87				<b>13</b>	94	1.0	223.92						
	<b>24</b>	37	1.4	124.81				<b>13</b>	99	0.9	236.83						
	<b>17</b>	54	0.9	181.35				<b>10</b>	126	0.7	300.07						
	<b>13</b>	67	0.8	224.32													
	<b>9.5</b>	86	0.6	315.05													
	<b>8.1</b>	86	0.6	368.19	<b>070/105/4</b>	<b>12E/24E</b>	(3000 min <sup>-1</sup> )	<b>146</b>	15	2.0	20.57	<b>180/105/3</b>	<b>120/240</b>				
	<b>5.6</b>	86	0.6	534.98				<b>90</b>	25	1.6	33.32						
	<b>4.5</b>	86	0.6	661.76				<b>68</b>	33	1.5	44.36						
	<b>3.2</b>	86	0.6	929.40				<b>55</b>	41	1.2	54.87						
	<b>160</b>	6	11.1	18.75	<b>070/146</b>	<b>12E/24E</b>		<b>42</b>	54	0.9	71.84						
	<b>115</b>	8	8.0	26.17				<b>39</b>	58	0.9	77.07						
	<b>106</b>	8	7.4	28.26				<b>34</b>	66	0.8	88.87						
	<b>86</b>	10	7.4	35.07				<b>160</b>	14	4.4	18.75			<b>180/146</b>	<b>120/240/24E</b>		
	<b>76</b>	12	6.6	39.44				<b>115</b>	20	3.2	26.17						
	<b>65</b>	14	5.6	46.44				<b>106</b>	21	3.0	28.26						
	<b>57</b>	16	4.9	52.86				<b>86</b>	26	3.0	35.07						
	<b>49</b>	18	4.7	60.63				<b>76</b>	30	2.6	39.44						
	<b>43</b>	21	4.1	70.00				<b>65</b>	35	2.2	46.44						
	<b>35</b>	25	3.4	84.63				<b>57</b>	40	2.0	52.86						
	<b>31</b>	29	3.0	95.61		<b>49</b>	45	1.9	60.63								
	<b>26</b>	34	2.5	113.40		<b>43</b>	52	1.6	70.00								
	<b>22</b>	40	2.1	133.45		<b>35</b>	63	1.4	84.63								
	<b>20</b>	45	1.9	150.18		<b>31</b>	72	1.2	95.61								
	<b>19</b>	48	1.9	160.43		<b>26</b>	85	1.0	113.40								
	<b>17</b>	54	1.7	178.83		<b>22</b>	100	0.9	133.45								
	<b>13</b>	67	1.4	223.92		<b>20</b>	112	0.8	150.18								
	<b>13</b>	71	1.3	236.83		<b>19</b>	120	0.8	160.43								
	<b>10</b>	90	1.0	300.07		<b>17</b>	134	0.7	178.83								
	<b>7.5</b>	119	0.8	397.38													
<b>140</b>							<b>350</b>										
(3000 min <sup>-1</sup> )	<b>146</b>	9	3.6	20.57	<b>100/105/3</b>	<b>120/240/24E</b>	(3000 min <sup>-1</sup> )	<b>160</b>	20	3.2	18.75	<b>250/146</b>	<b>120/240</b>				
	<b>90</b>	14	2.8	33.32				<b>115</b>	27	2.3	26.17						
	<b>68</b>	19	2.7	44.36				<b>106</b>	30	2.1	28.26						
	<b>55</b>	23	2.2	54.87				<b>86</b>	37	2.1	35.07						
	<b>42</b>	30	1.7	71.84				<b>76</b>	41	1.9	39.44						
	<b>39</b>	32	1.6	77.07				<b>65</b>	49	1.6	46.44						
	<b>34</b>	37	1.4	88.87				<b>57</b>	55	1.4	52.86						
	<b>24</b>	52	1.0	124.81				<b>49</b>	64	1.4	60.63						
	<b>16.5</b>	76	0.7	181.35				<b>43</b>	73	1.2	70.00						
	<b>160</b>	8	7.9	18.75			<b>100/146</b>	<b>120/240/24E</b>		<b>35</b>	89			1.0	84.63		
	<b>115</b>	11	5.7	26.17		<b>31</b>			100	0.9	95.61						
	<b>106</b>	12	5.3	28.26		<b>26</b>			119	0.7	113.40						
	<b>86</b>	15	5.3	35.07													
	<b>76</b>	17	4.7	39.44													
	<b>65</b>	19	4.0	46.44													
	<b>57</b>	22	3.5	52.86													
	<b>49</b>	25	3.4	60.63													
	<b>43</b>	29	2.9	70.00													
	<b>35</b>	35	2.4	84.63													

NOTA  
Verificare sempre che la coppia M2 utilizzata non ecceda il valore indicato nelle caselle in grigio

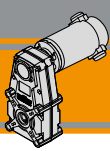

NOTE  
Please check that the output torque M2 does not exceed the value in the grey areas

ECFT



## Dati tecnici

## Technical data

$P_1$ [W]	$n_2$ [min <sup>-1</sup> ]	$M_2$ [Nm]	sf	i		Versione motore Motor version	$P_1$ [W]	$n_2$ [min <sup>-1</sup> ]	$M_2$ [Nm]	sf	i		Versione motore Motor version	
<b>350</b>							<b>800</b>							
(3000 min <sup>-1</sup> )	<b>147</b>	21	12.8	20.41	<b>250/196</b>	<b>120/240</b>	(3000 min <sup>-1</sup> )	<b>160</b>	45	1.4	18.75	<b>600/146</b>	<b>120/240</b>	
	<b>86</b>	36	8.6	34.81				<b>115</b>	63	1.0	26.17			
	<b>70</b>	45	7.9	42.61				<b>106</b>	68	0.9	28.26			
	<b>51</b>	62	6.3	59.36				<b>86</b>	84	0.9	35.07			
	<b>41</b>	76	5.6	72.68				<b>76</b>	94	0.8	39.44			
	<b>32</b>	97	4.4	92.82				<b>65</b>	111	0.7	46.44			
	<b>24</b>	130	3.3	123.95				<b>147</b>	49	5.6	20.41			
	<b>19</b>	165	2.6	158.02				<b>86</b>	83	3.7	34.81			
	<b>15</b>	211	2.0	201.80		<b>70</b>	102	3.4	42.61					
	<b>11</b>	282	1.5	269.47		<b>51</b>	142	2.7	59.36					
							<b>41</b>	174	2.5	72.68				
							<b>32</b>	222	1.9	92.82				
							<b>24</b>	297	1.4	123.95				
							<b>19</b>	378	1.1	158.02				
							<b>15</b>	483	0.9	201.80				
<b>500</b>														
(3000 min <sup>-1</sup> )	<b>160</b>	28	2.2	18.75	<b>350/146</b>	<b>120/240</b>								
	<b>115</b>	39	1.6	26.17										
	<b>106</b>	42	1.5	28.26										
	<b>86</b>	52	1.5	35.07										
	<b>76</b>	59	1.3	39.44										
	<b>65</b>	69	1.1	46.44										
	<b>57</b>	79	1.0	52.86										
	<b>49</b>	91	0.9	60.63										
	<b>43</b>	105	0.8	70.00										
	<b>147</b>	31	8.9	20.41	<b>350/196</b>	<b>120/240</b>								
	<b>86</b>	52	6.0	34.81										
	<b>70</b>	64	5.5	42.61										
	<b>51</b>	89	4.4	59.36										
	<b>41</b>	109	3.9	72.68										
	<b>32</b>	139	3.1	92.82										
	<b>24</b>	185	2.3	123.95										
	<b>19</b>	236	1.8	158.02										
	<b>15</b>	302	1.4	201.80										
	<b>11</b>	403	1.1	269.47										

## Motori applicabili

## Motor adapters

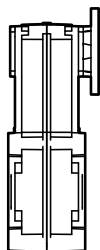
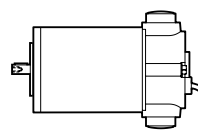

		EC						
		070.12E 070.24E	100.120 100.240 100.24E	180.120 180.240	180.24E	250.120 250.240	350.120 350.240	600.120 600.240
FT	105/3	20.57 - 315.05	20.57 - 315.05	20.57 - 315.05				
	105/4	368.19 - 929.4	368.19 - 929.4	368.19 - 929.4				
	146	18.75 - 397.38	18.75 - 397.38	18.75 - 397.38	18.75 - 397.38	18.75 - 397.38	18.75 - 397.38	18.75 - 397.38
	196		(*)	(*)	(*)	20.41 - 269.47	20.41 - 269.47	20.41 - 269.47

20.57 - 315.05

Rapporti di riduzione i  
Ratio i

(\*) Motore applicabile con portaspazzola inclinato di 45°.

Si prega di contattare il nostro servizio tecnico.

(\*) Motor assembly with brush holder inclined 45°.

Please contact our technical service.



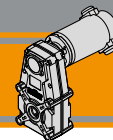

Dimensioni

Dimensions

ECFT 070/105

ECFT 070/105...U

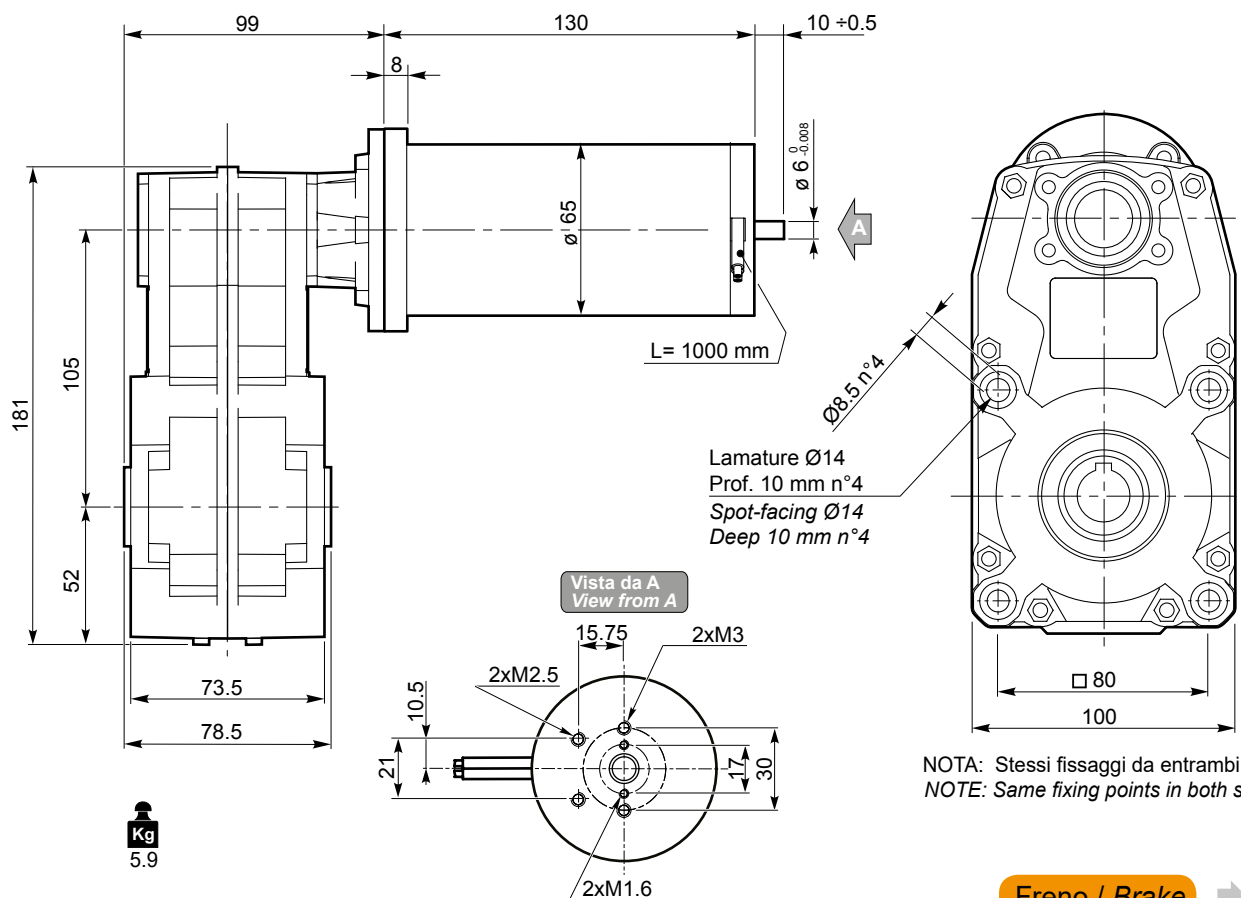

NOTA: Stessi fissaggi da entrambi i lati  
NOTE: Same fixing points in both sides

Freno / Brake

H23

Encoder

H24

Motori / Motors IP66

I2

ECFT

O17

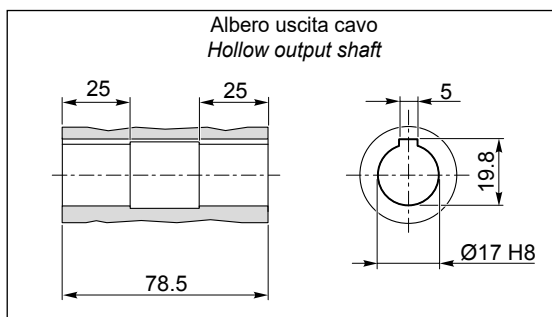

O20

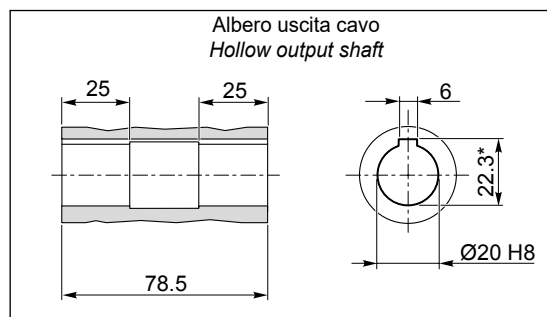

\*: Sede linguetta ribassata / Special keyway

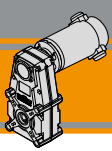

**ECFT 100/105**

**ECFT 100/105...U**

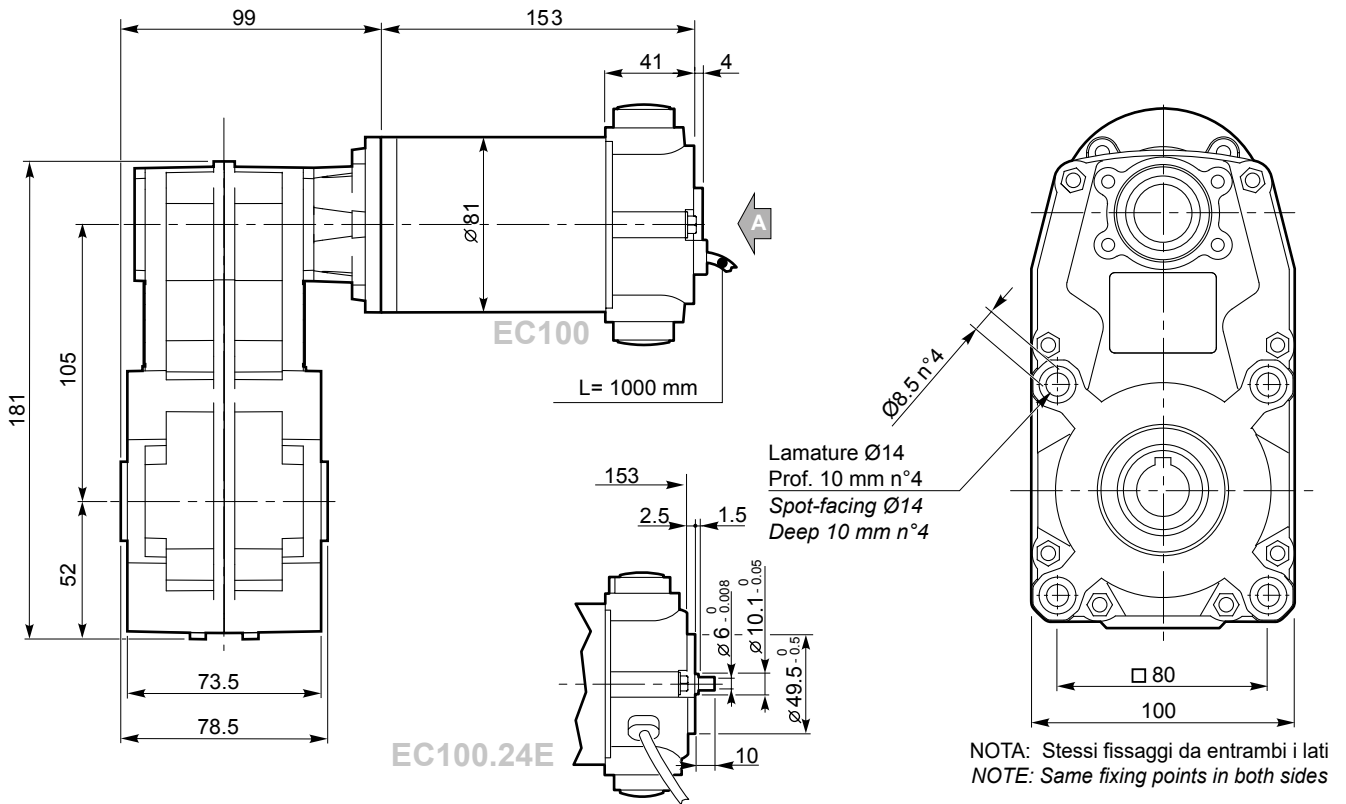

**Kg**  
6.9

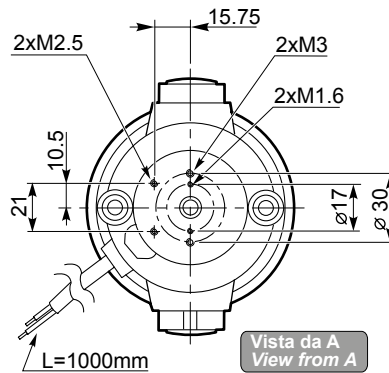

Freno / Brake → H23

Encoder → H24

Motori / Motors IP66 → I4

**O17**

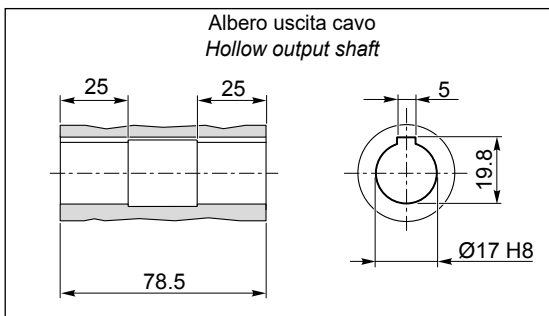

**O20**

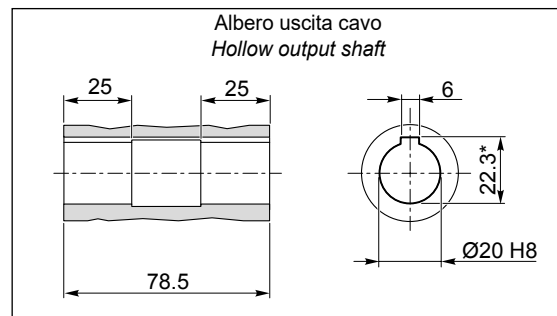

\*: Sede linguetta ribassata / Special keyway

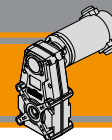

Dimensioni

Dimensions

ECFT 180/105

ECFT 180/105...U

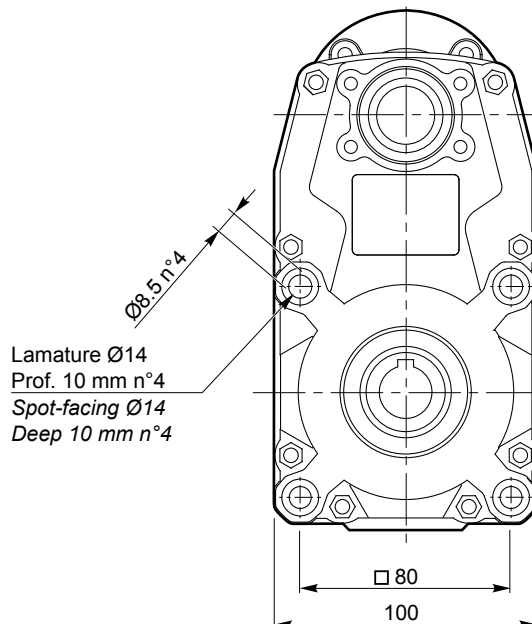
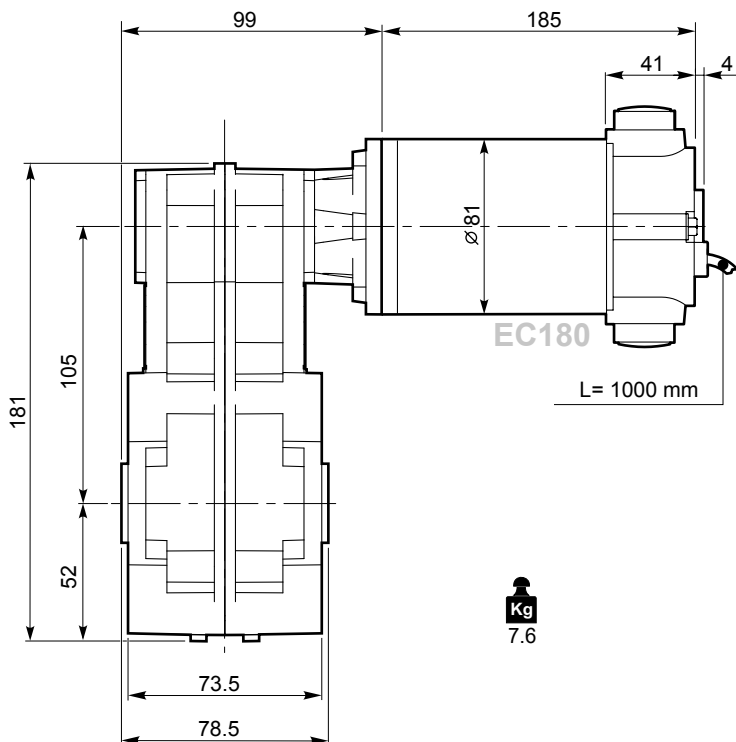

NOTA: Stessi fissaggi da entrambi i lati  
NOTE: Same fixing points in both sides

Freno / Brake → H23

Encoder → H24

Motori / Motors IP66 → I6

O17

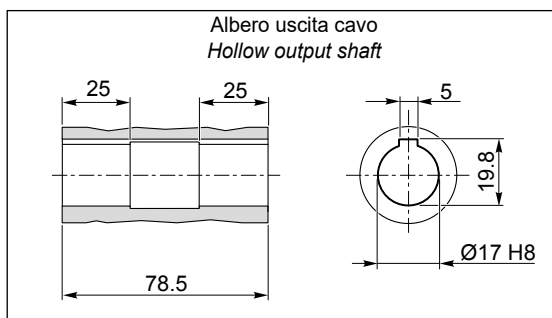

O20

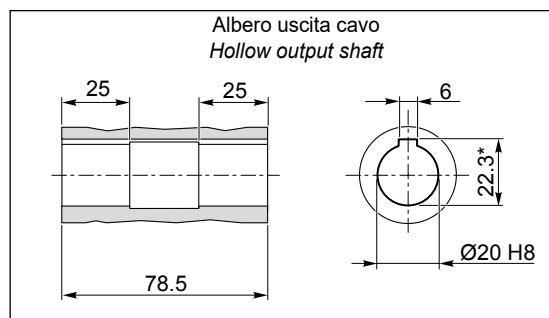

\*: Sede linguetta ribassata / Special keyway

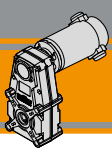

**ECFT 070/146**

**ECFT 070/146 U**

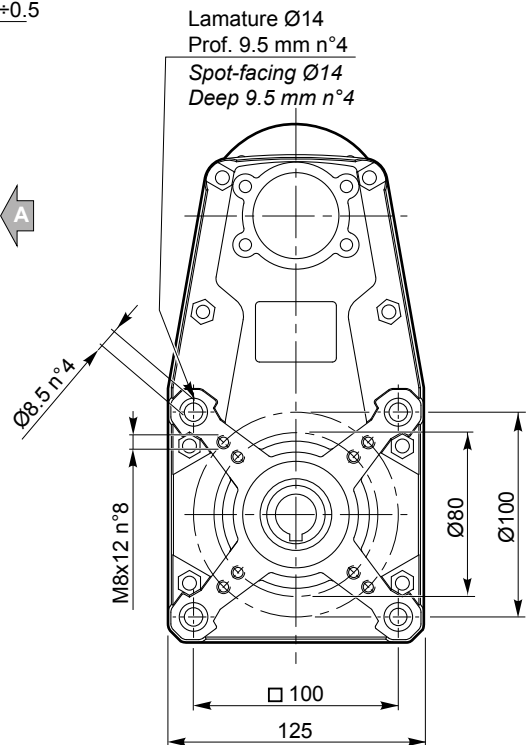
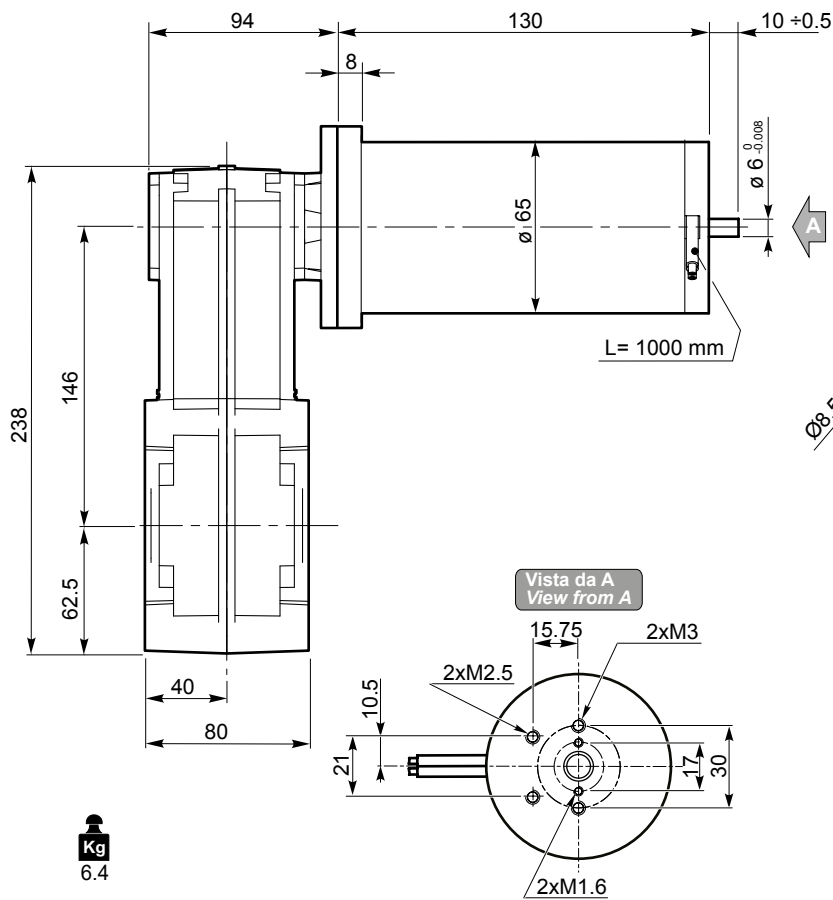

NOTA: Stessi fissaggi da entrambi i lati  
NOTE: Same fixing points in both sides

Freno / Brake → H23

Encoder → H24

Motori / Motors IP66 → I2

**O20**

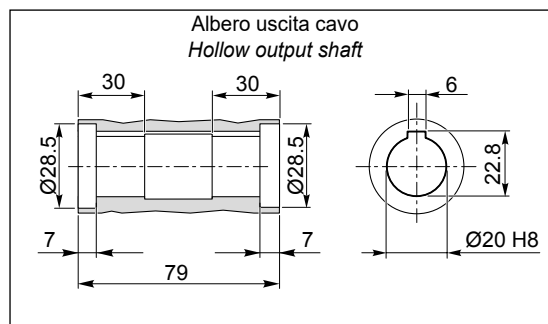

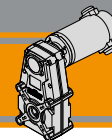

Dimensioni

Dimensions

ECFT 100/146

ECFT 100/146 U

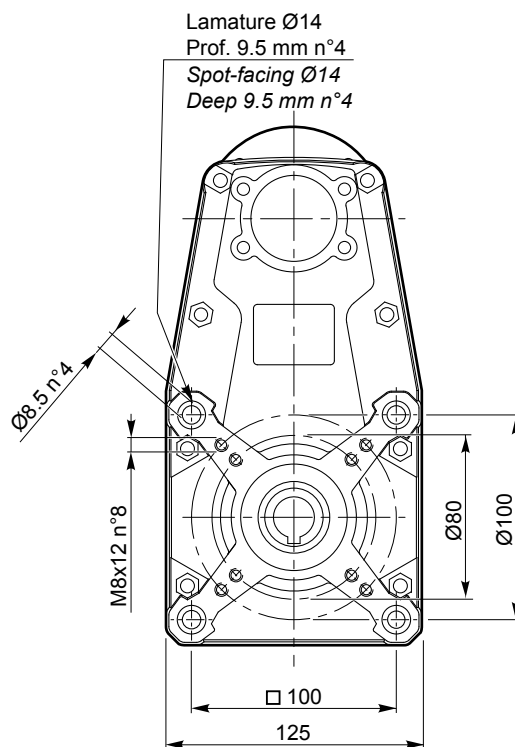
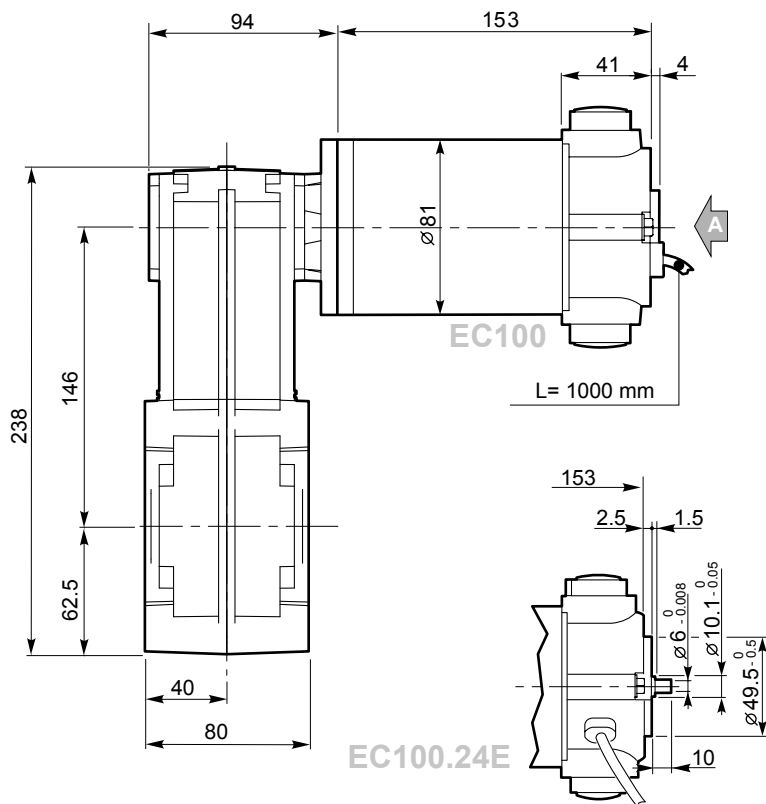

NOTA: Stessi fissaggi da entrambi i lati  
NOTE: Same fixing points in both sides

**Kg**  
7.4

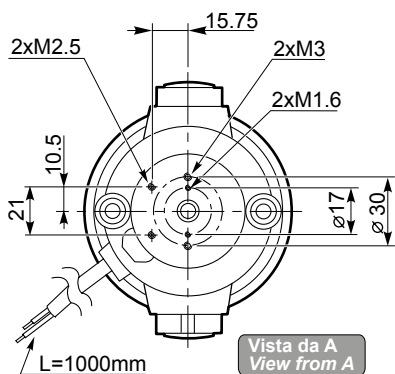

- Freno / Brake → H23
- Encoder → H24
- Motori / Motors IP66 → I4

ECFT

O20

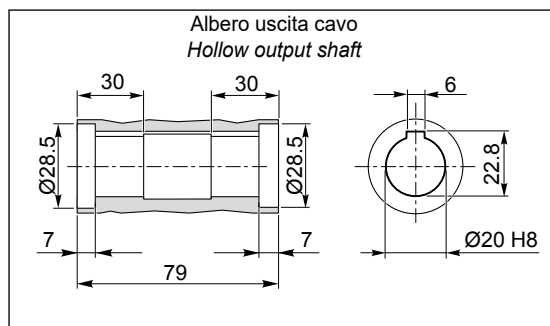

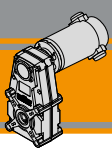

### ECFT 180/146

### ECFT 180/146 U

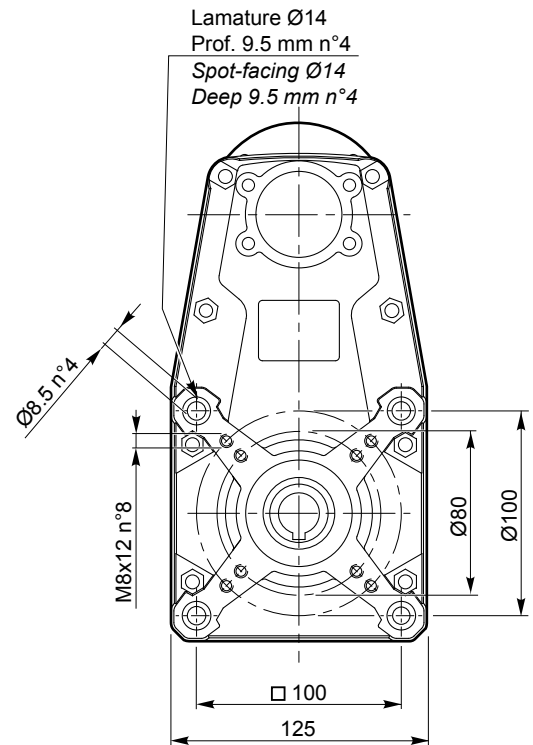
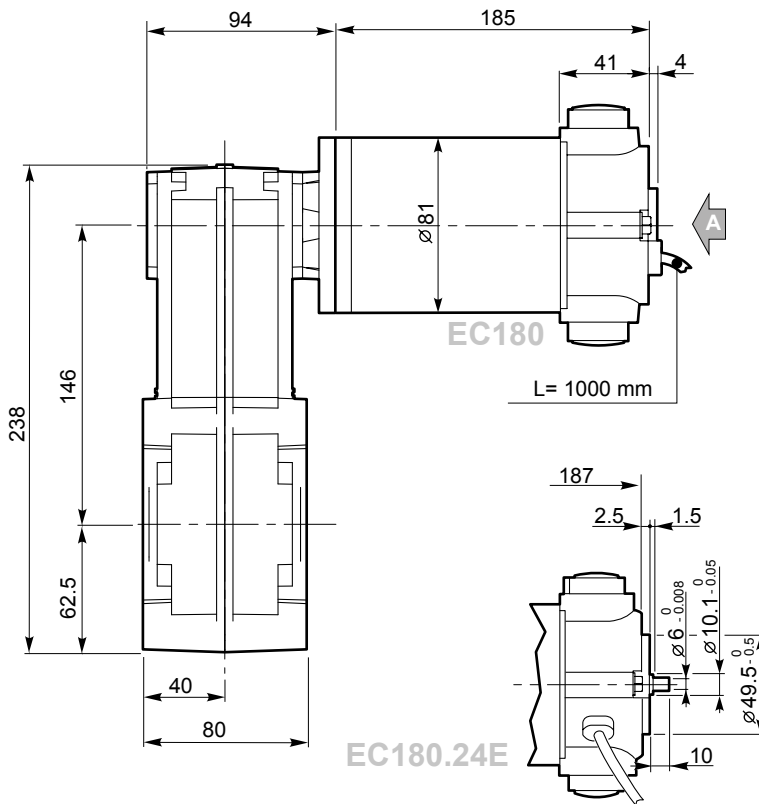

NOTA: Stessi fissaggi da entrambi i lati  
NOTE: Same fixing points in both sides

**Kg**  
8.1

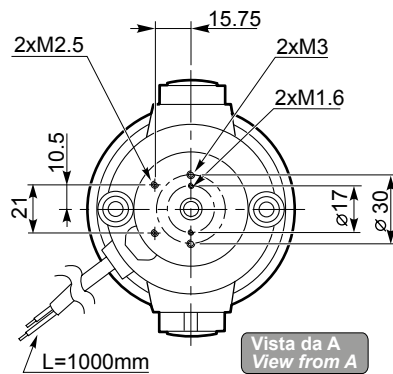

Freno / Brake

H23

Encoder

H24

Motori / Motors IP66

I6

### O20

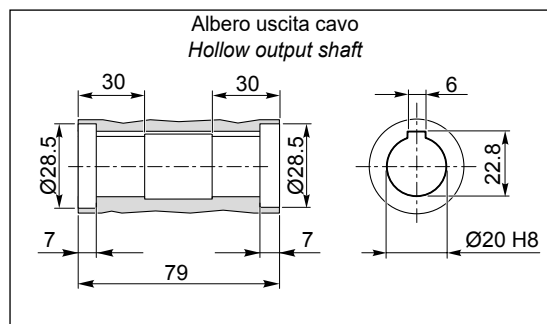

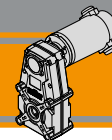

Dimensioni

Dimensions

ECFT 250/146

ECFT 250/146 U

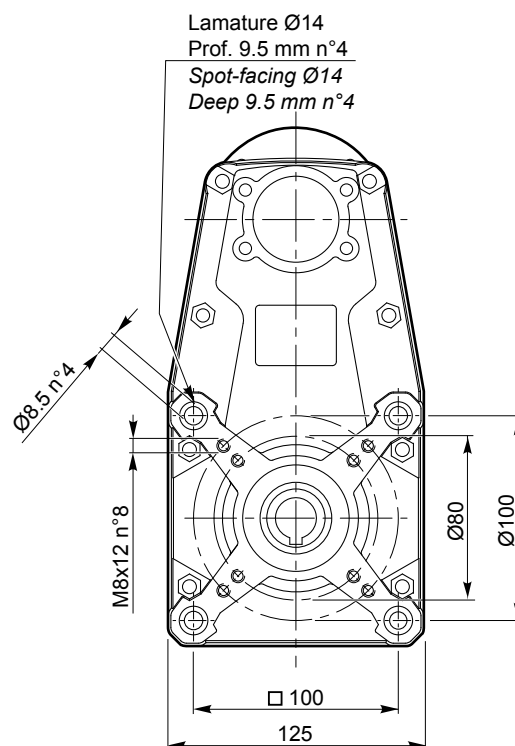
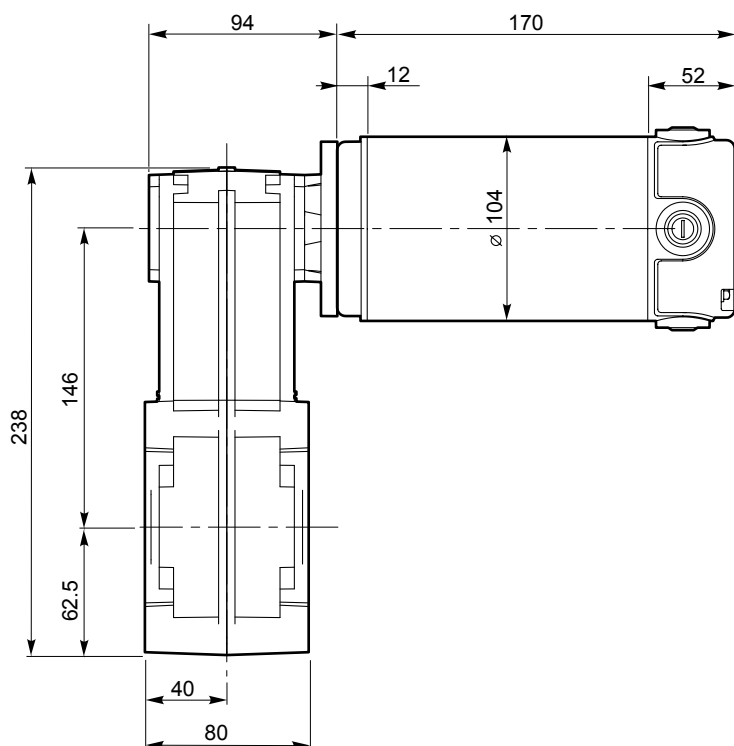

**Kg**  
8.9

NOTA: Stessi fissaggi da entrambi i lati  
NOTE: Same fixing points in both sides

Motori / Motors IP66

18

ECFT

O20

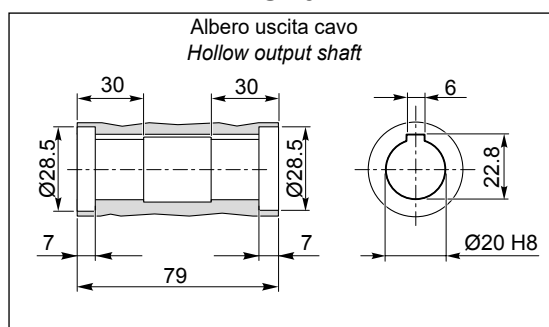

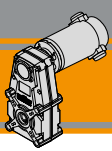

Dimensioni

Dimensions

**ECFT 350/146**

**ECFT 350/146 U**

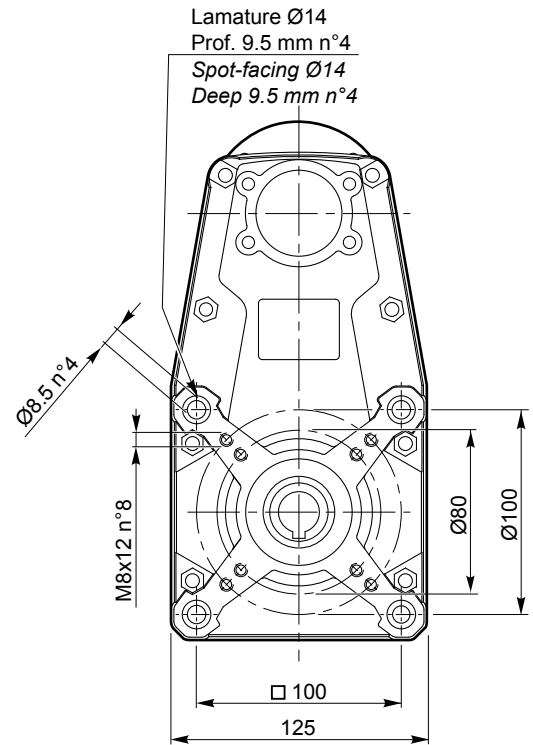
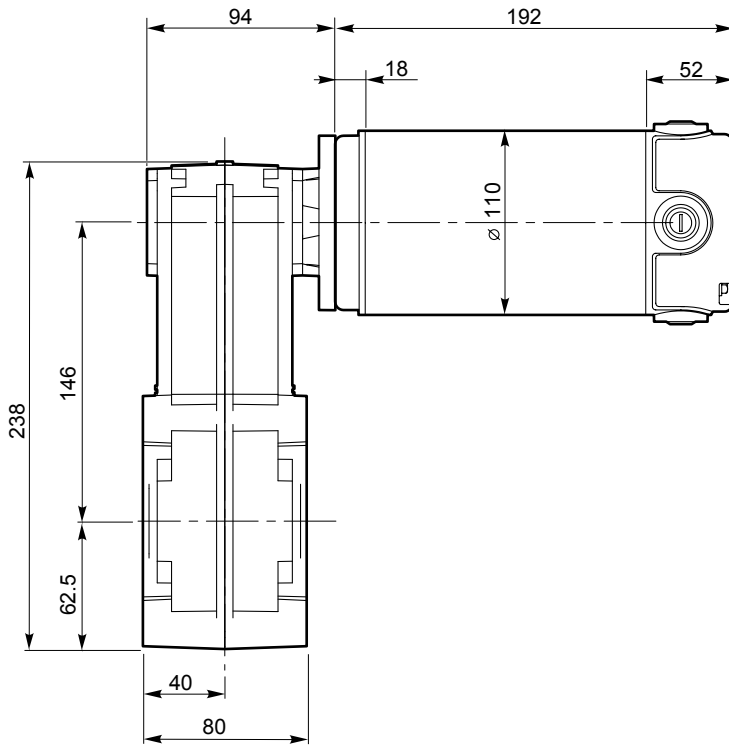

NOTA: Stessi fissaggi da entrambi i lati  
NOTE: Same fixing points in both sides

**Kg**  
10.0

Freno / Brake

H23

Motori / Motors IP66

I10

**O20**

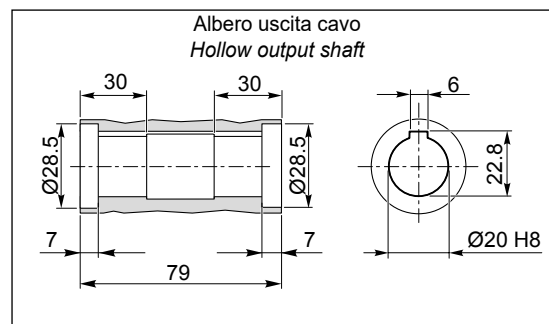



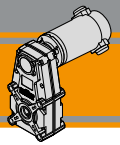

Dimensioni

Dimensions

ECFT 600/146

ECFT 600/146 U

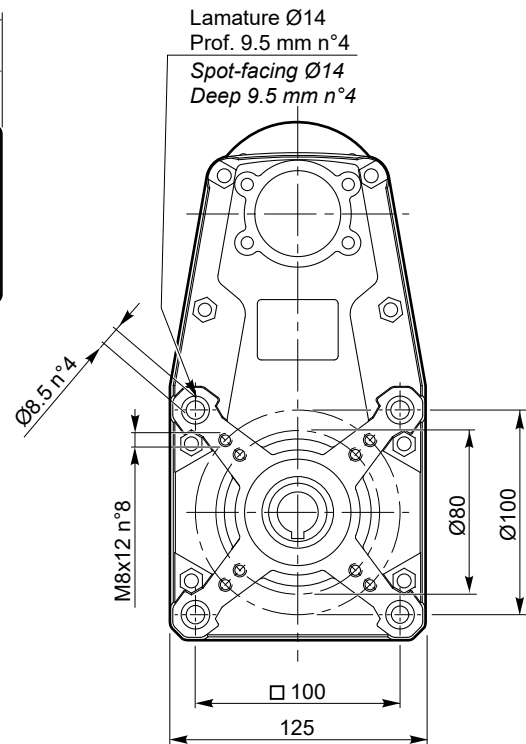
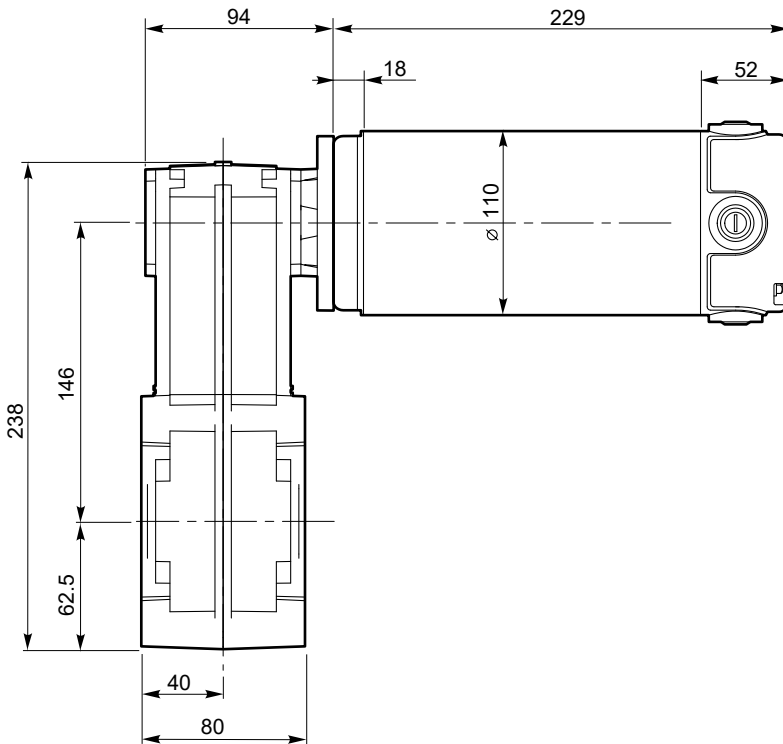

11.8

NOTA: Stessi fissaggi da entrambi i lati  
NOTE: Same fixing points in both sides

Freno / Brake → H23

Motori / Motors IP66 → I10

O20

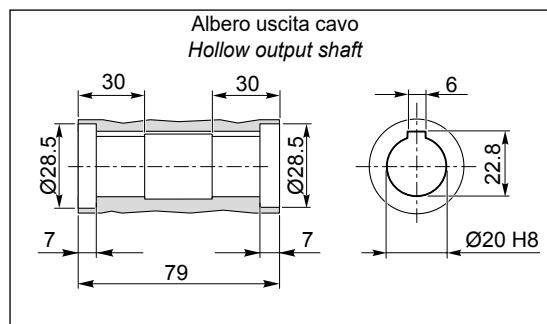

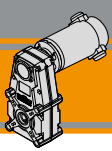

## ECFT 250/196

### ECFT 250/196 U

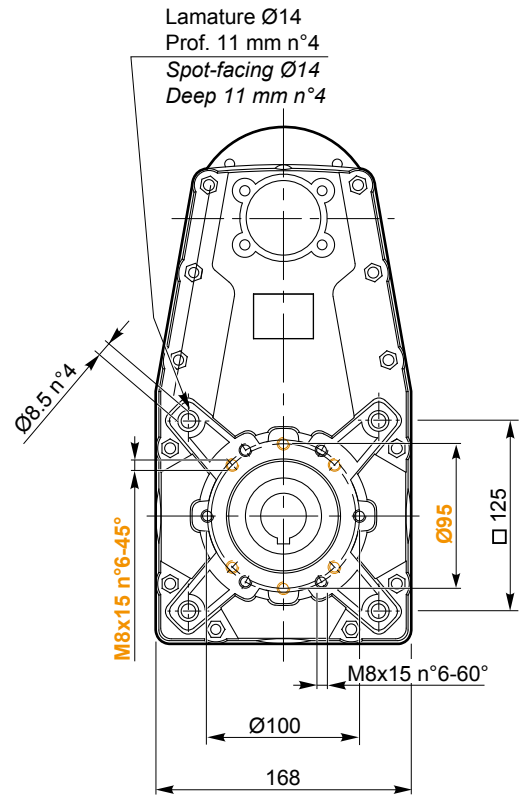
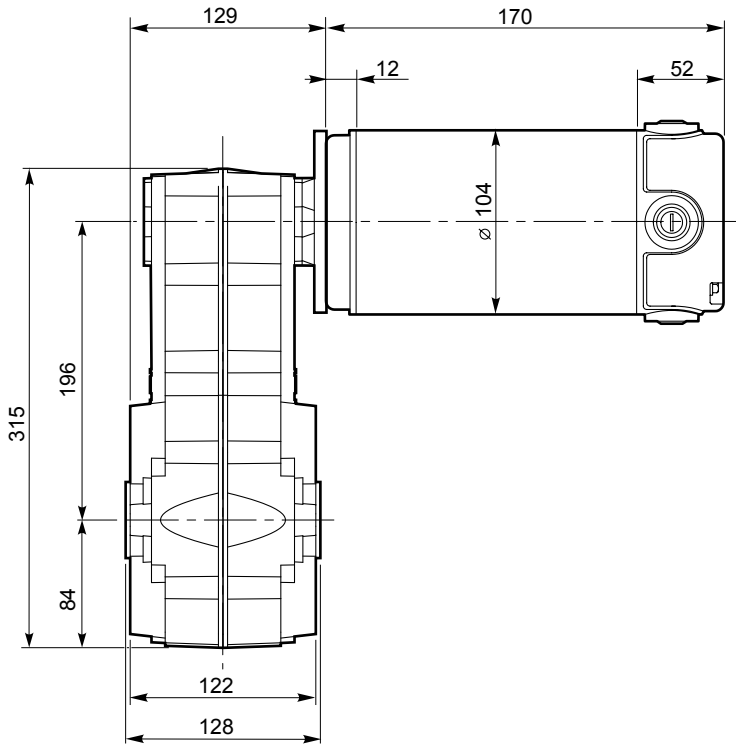

**Kg**  
16.3

NOTA: Stessi fissaggi da entrambi i lati  
NOTE: Same fixing points in both sides

Motori / Motors IP66

18

### O30

Albero uscita cavo  
Hollow output shaft

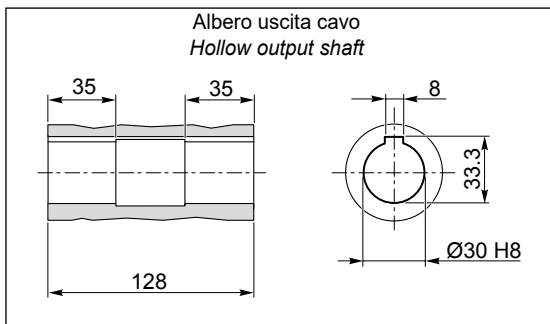

### O35

Albero uscita cavo  
Hollow output shaft

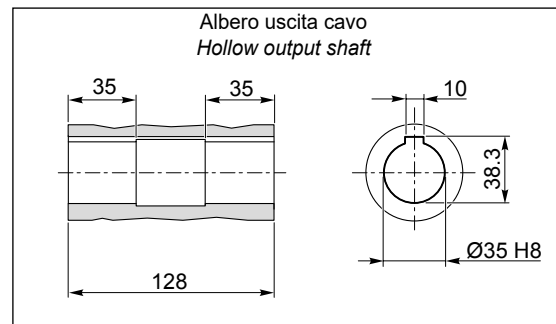

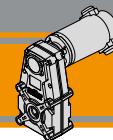

Dimensioni

Dimensions

ECFT 350/196

ECFT 350/196 U

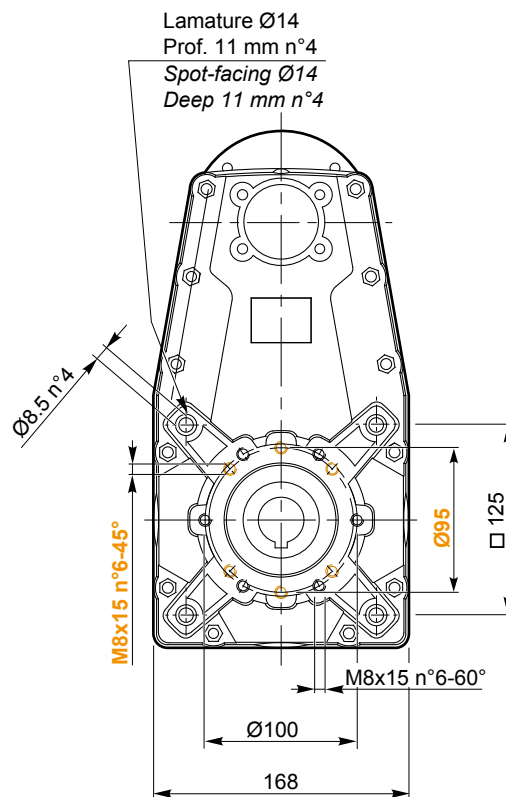
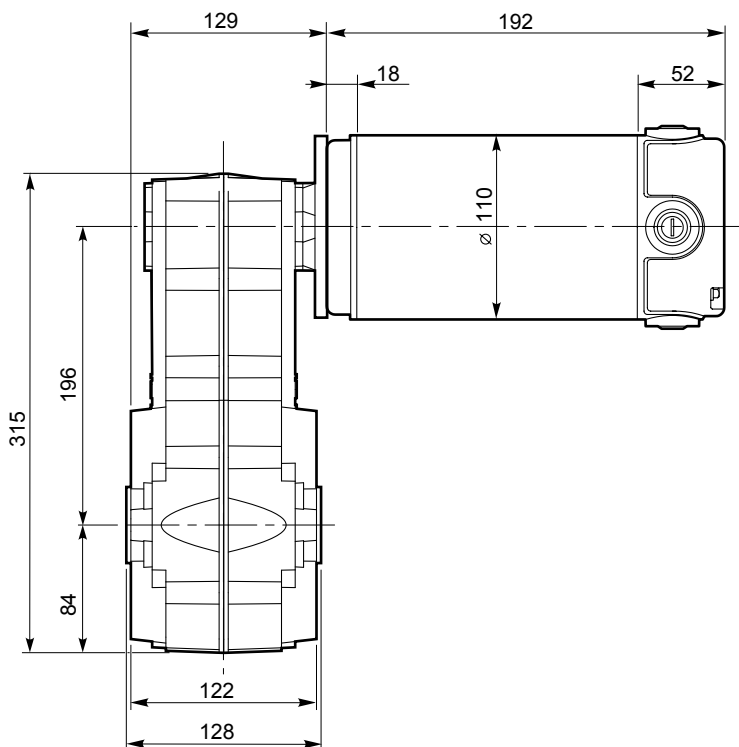

**Kg**  
17.4

NOTA: Stessi fissaggi da entrambi i lati  
NOTE: Same fixing points in both sides

Freno / Brake

H23

Motori / Motors IP66

I10

ECFT

O30

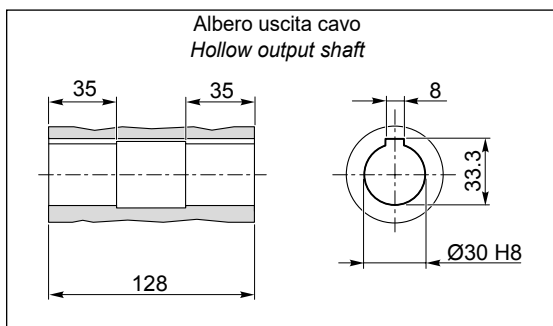

O35

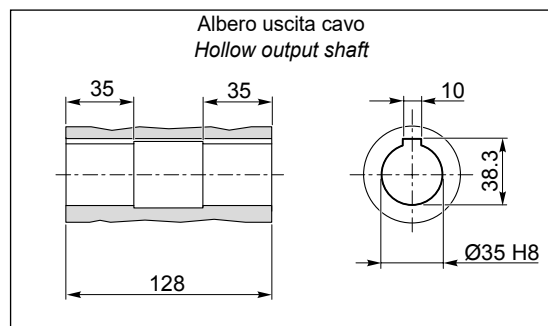

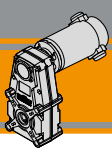

## ECFT 600/196

### ECFT 600/196 U

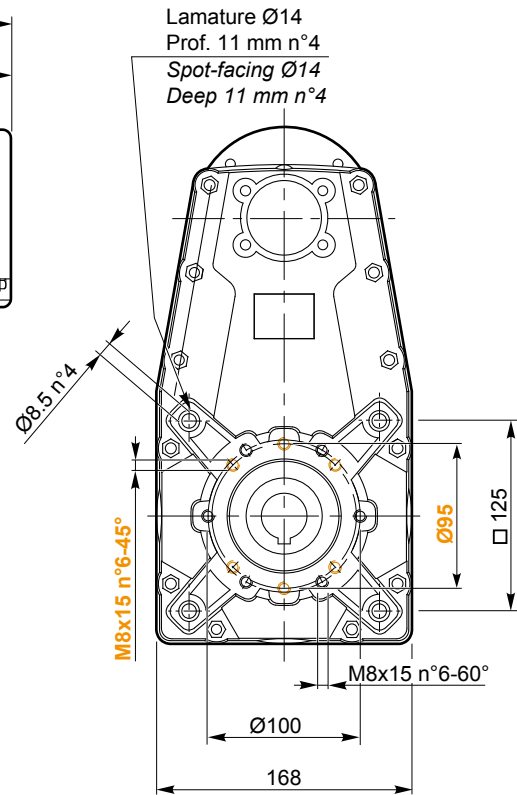
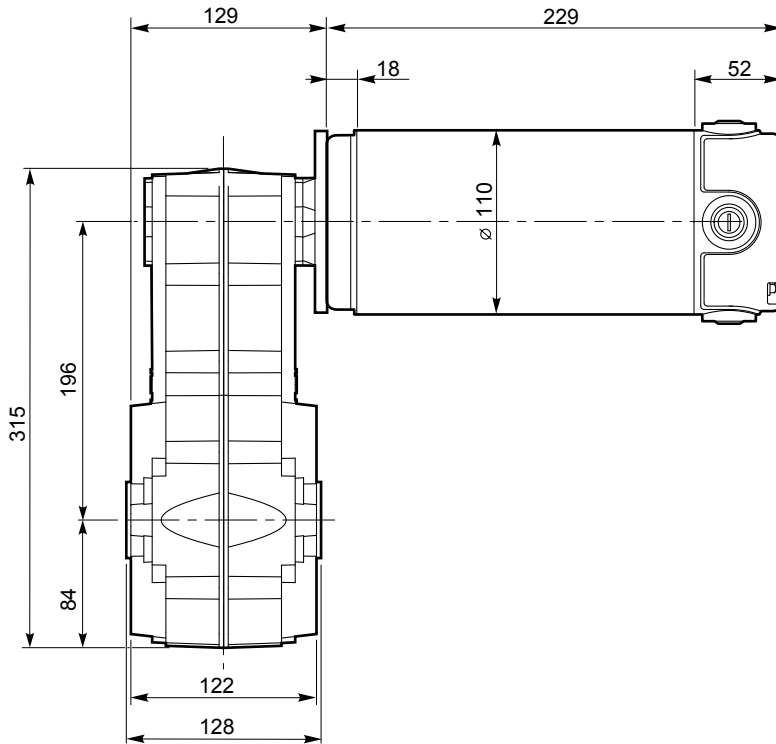

**Kg**  
19.2

NOTA: Stessi fissaggi da entrambi i lati  
NOTE: Same fixing points in both sides

Freno / Brake

H23

Motori / Motors IP66

I12

### O30

Albero uscita cavo  
Hollow output shaft

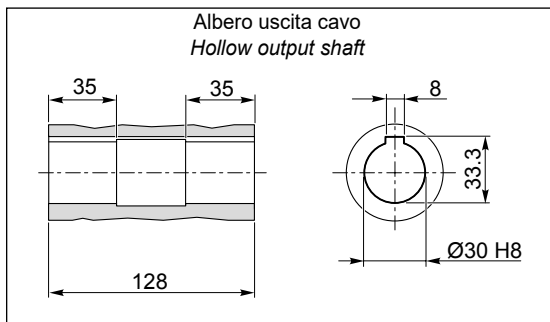

### O35

Albero uscita cavo  
Hollow output shaft

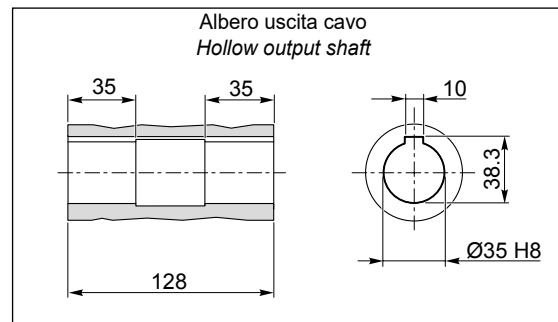



**MA TRANSTECNO S.A.P.I. DE C.V.**  
 Av. Mundial # 176, Parque Industrial  
 JM Apodaca, Nuevo León,  
 C.P. 66600  
 MÉXICO  
 T +52 8113340920  
 info@transtecno.com.mx  
 www.transtecno.com.mx



**TRANSTECNO SRL**  
 Via Caduti di Sabbiano, 11/D-E  
 40011 Anzola dell'Emilia (BO)  
 ITALY  
 T+39 051 64 25 811  
 F +39 051 73 49 43  
 sales@transtecno.com  
 www.transtecno.com



**HANGZHOU TRANSTECNO POWER TRANSMISSIONS CO LTD**  
 No.4 Xiuyan Road Fengdu Industry Zone  
 Pingyao Town Yuhang District  
 Hangzhou City, Zhejiang Province  
 311115 – CHINA  
 T +86 571 86 92 02 60  
 F +86 571 86 92 18 10  
 info-china@transtecno.com  
 www.transtecno.cn



**TRANSTECNO U.S.A. LLC**  
 5440 S.W. 156th Place Miami,  
 FL 33185 - USA  
 Tel: +1 (305) 220-4423  
 Fax: +1 (305) 220-5945  
 usaoffice@transtecno.com



**TRANSTECNO B.V.**  
 Ind. terrein Wieken/Vinkenhof  
 De Stuwdam,43  
 3815 KM Amersfoort - NETHERLANDS  
 Tel: +31(0) 33 45 19 505  
 Fax: +31(0) 33 45 19 506  
 info@transtecno.nl  
 www.transtecno.nl



**SALES OFFICE INDIA**  
 A/10, Anagha, S.N. Road, Mulund (W) Mumbai  
 400080 - INDIA  
 Tel: +91 9820614698  
 Fax-Italy: +39 051 73 49 43  
 indiaoffice@transtecno.com



**SALES OFFICE BRAZIL**  
 Rua Dr. Freire Alemão 155 / 402 - CEP. 90450-060  
 Auxiliadora Porto Alegre RS - BRAZIL  
 Tel: +55 51 3251 5447  
 Fax: +55 51 3251 5447  
 Mobile: +55 51 811 45 962  
 braziloffice@transtecno.com  
 www.transtecno.com.br



**TRANSTECNO AANDRIJFTECHNIEK B.V.**  
 De Stuwdam 43  
 3815 KM Amersfoort - NETHERLANDS  
 Tel: +31 (0) 33 20 4 7 006  
 info@transtecnoaandrijftechnik.nl  
 www.transtecnoaandrijftechnik.nl



**SALES OFFICE SOUTH KOREA**  
 D-304 Songdo BRC Smart Valley 30, Songdomirae-ro,  
 Yeonsu-gu, Incheon, 406-840 - KOREA  
 Tel: +82 70 8288 2107  
 Fax: +82 32 815 2107  
 Mobile: +82 10 5094 2107  
 koreaoffice@transtecno.com



**TRANSTECNO IBÉRICA  
 THE MODULAR GEARMOTOR, S.A.**  
 C/Enginy, 2 Nave 6 - 08850 Gavà (Barcelona) - SPAIN  
 Tel: +34 931 598 950  
 info@transtecno.es  
 www.transtecno.es



**SALES OFFICE OCEANIA**  
 44 Northview drive, Sunshine west 3020  
 Victoria - AUSTRALIA  
 Ph +61 03 9312 4722  
 Fax +61 03 9312 4714  
 Mobile: +61 0438060997  
 oceaniaoffice@transtecno.com  
 www.transtecno.com.au



**SALES OFFICE FRANCE**  
 Tel: +33 (0) 6 85 12 09 87  
 Fax-Italy: +39 051 73 49 43  
 franceoffice@transtecno.com  
 www.transtecno.fr

  
**TRANSTECNO**<sup>®</sup>  
 the modular gearmotor  
 www.transtecno.com